

Lopoco Patents Description

I. Device(s) to smooth and direct cooling air flow inside a computer.

- (a) Small devices that can be attached to the computer motherboard to aerodynamically smooth the flow of cooling air around and/or above protuberances and blockages (I/O ports; I/O headers; electrical components such as capacitors, transistors, coils, etc.; cable attachment headers; the motherboard itself) that normally have a rectangular or other non-aerodynamic shape which blocks efficient air flow. Optimizing the air flow around such blockages allows for more efficient cooling of the computer, which allows for a reduction in the amount of fan power required.
- (b) The shape of air flow blockers inside a computer case are usually rectangular or of a rectangular cross section. This is because these blockages are most commonly the rear I/O ports attached at the back of the motherboard. But other devices or objects can also block the flow of cooling air. Batteries, speakers, electrical coils, capacitors and other components on the motherboard. The motherboard itself is not aerodynamically optimized, hence one of the devices is designed specifically to direct all air flow coming from the fans above the motherboard where it can do the most good.
- (c) In the case of wider blockages such as multiple I/O headers mounted side by side on the motherboard, the devices are intended to be used in groups. The size of the devices would be chosen to match the height and width of the blockage(s).
- (d) The device(s) will have various shapes, including:
 - 1. Basic vertical wedge shape, as seen in Fig. 1C (side view sketch). This shape is designed to transition air flow over the top of the blockage.

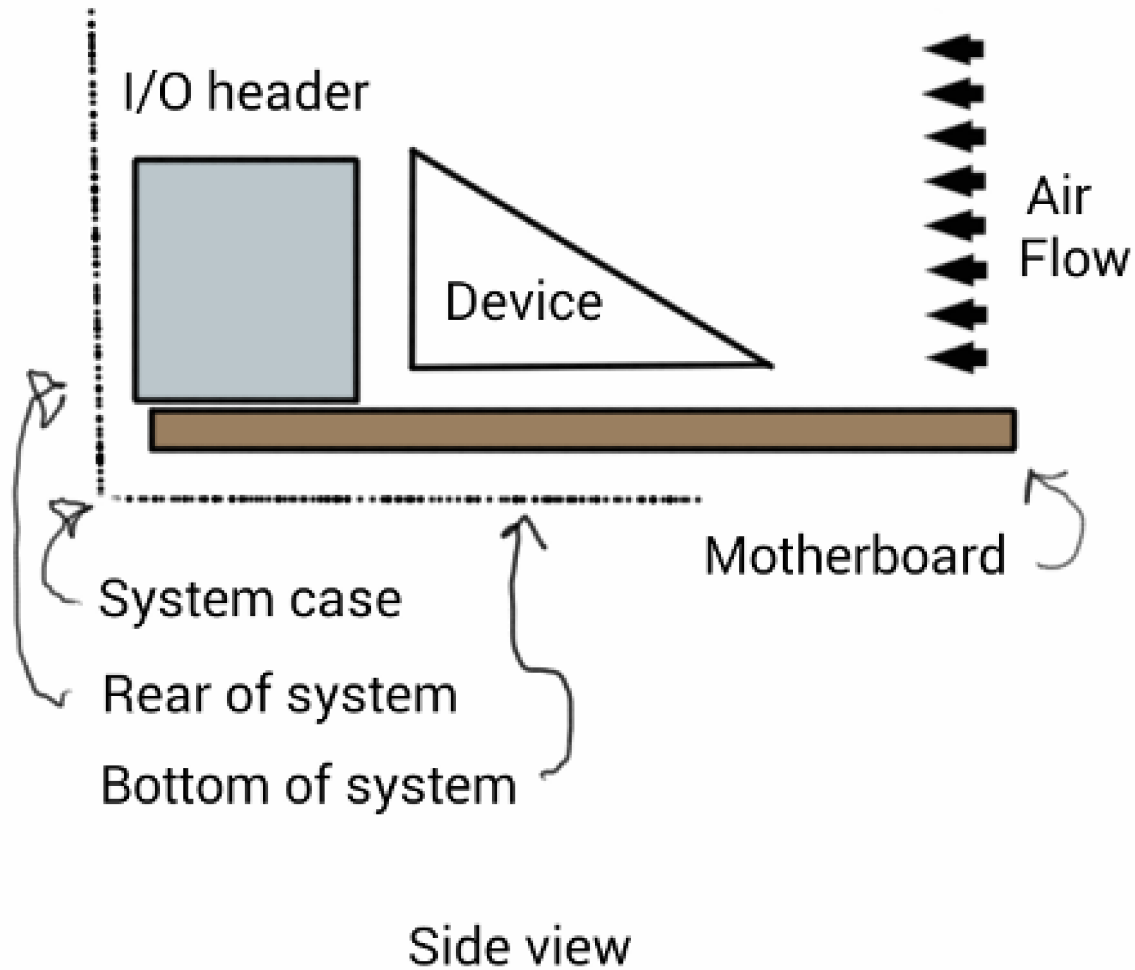

Fig. 1c

2. Basic blended vertical and horizontal wedge, used to transition air flow over and around a single blockage. This shape would more or less come to a point at the leading edge, resembling a cone cut in half from top to bottom and then laid flat, with the pointed end pointed towards the air source, most likely a fan or fans. The tail end of the device would not necessarily be rounded like a simple cone, but be a match for the vertical cross section of the blockage itself, and that shape gradually shrinking towards the leading end of the device.

[drawings and illustrations]

3. Devices that are essentially device shape #2 cut into right and left halves. These are to be used in conjunction with device shape #1 to create a complete air flow transition

around larger blockages possibly consisting of multiple I/O headers mounted side by side or nearly so.

4. Rounded versions of the above described shapes.

- (e) The devices are made of a very smooth, hard material, most likely plastic for costs and light weight, facilitating good air flow.
- (f) The devices may have a thin, soft layer on the motherboard side that is coated with reusable adhesive. The soft layer is malleable and does not rebound, allowing the device to be pressed down over small surface mount components that may be on the motherboard in front of the blockage(s). Not applicable when device shapes are built in to components or headers.
- (g) This claim would also include such designs or shapes described above, but integrated into the external case of the I/O header or component itself.

II. 42mm system fans for use inside a computer server case

- (a) Computer server cases that are 1U tall (1.7 inches or 43mm) suffer from lack of efficient cooling fan solutions, because the internal case volume is relatively small. Fans that are situated inside such cases are referred to as case fans. This is a design for 42mm case fans specifically for optimizing efficiency of cooling.
- (b) Current 1U case fans are 40mm square, and anywhere from 5mm to 25mm deep, or deeper. This fan design specifies 42mm fans, thereby leaving no amount of internal space empty.
- (c) Fans have “disappearing” frame segments on the top of the fan, so that the blades come as close as possible to the top (or bottom) of the case, maximizing available space. This means, among other things, that the fans can reasonably only be installed in the case one of two ways: that is, with the open frame side facing the top or bottom of the case. It also means the external dimensions of the fans may not be square, but in fact wider in the horizontal than in the vertical.
- (d) Fans are generally made of plastic. Plastic frame and plastic blades. These fans will have soft touch plastic at least on the bottom and top of the frame, so as to damp vibrations coming from the fan, minimizing the amount of vibrations transmitted to the rest of the computer server and its components. Also, this soft touch plastic, a common material often found in car dashboards and other consumer products, will aid in holding the fans in place.

III. Computer system fans that can, besides varying their RPM and thus varying the amount of

power they draw and the amount of air they pump, can completely stop the fan motor, essentially drawing no power. Either through a communication signal via an interface, or merely by setting the fan supply voltage to zero, the fan will stop. The fan can start again when signaled to do so or when supply voltage is nominal levels. This will significantly reduce the amount of power consumed by a computer when it is in idle or low power mode, and passive convection cooling is sufficient to cool the system or parts of the system.

IV. Computer server motherboard design elements for increasing overall power efficiency

- (a) 5-Volt fan headers, allowing the use of 5V fans which typically can use much less power than traditional 12 volts fans, at least in servers that don't need very high speed, and/or high pressure, fans.
- (b) Memory, cable connectors and other components that are wider in one aspect than another, are mounted with the thinner aspect in line with the direction of cooling air flowing through the computer, thus increasing cooling efficiency. This is shown in low detail in Fig. 5b.

V. BIOS/Boot up code for ultra efficient server

- (a) Boot up and self test ROM or NVRAM code (herein called BIOS or POST code) that greatly decreases the amount of power consumed during the boot and self test phase. Current BIOS code in PC derived computer systems including servers utilizes a continuous loop design meant to refresh the video display. The use of directly connected video displays is a long since deprecated practice for servers. Our boot up code would dispense with the continuous loop video refresh code altogether and utilize an interrupt driven design, thereby drastically reducing power consumption during boot up, system test, and interactive operations.
- (b) Fan management code capable of turning one or more of the cooling fans off, or put another way, RPM of zero, when fan operation isn't required to cool the system.
- (c) Significantly increase the effectiveness of thermal management code, especially in the particular area of fan control, in the BIOS to help reduce power consumption of the system during operation.

VI. Computer server case and motherboard design elements for more efficient air flow through the case

- (a) This description covers new computer server motherboard design elements, and matching case design elements, to facilitate less restricted air flow through the case, thus increasing

cooling efficiency of the running computer server.

- (b) Below is a sketch (Fig. 5b) showing the motherboard design with the rear I/O ports located to the right side of the rear edge of the motherboard. This allows substantially less restricted airflow through the case of cooling air moved by internal cooling fans. With the rear I/O headers and ports moved out of the way, the cooling air can exit the case substantially easier, allowing the use of less powerful fans to cool the internal components of the computer server, which in turn reduces the amount of energy consumed overall by the computer server.

Fig. 5b

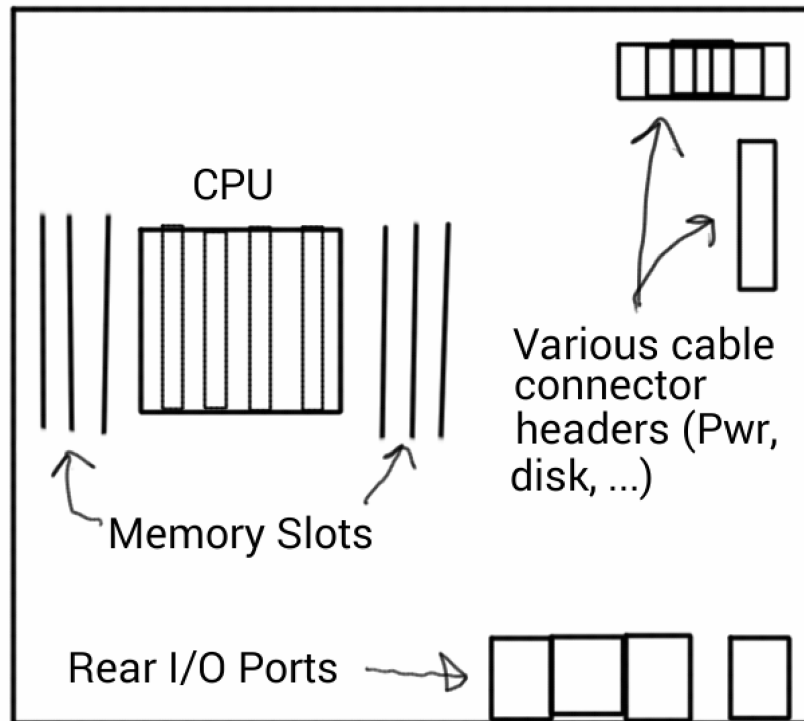
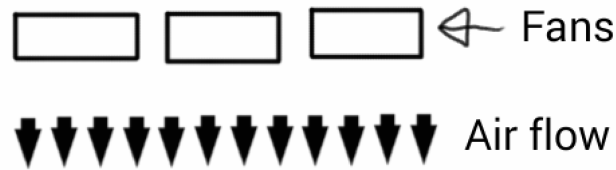

Motherboard top view

VII. Air intake and exhaust grill design

- (a) Currently, all computer server cases consist of a grill pattern stamped or cut out of sheet metal, usually aluminum. The thickness of the grill hatching is usually 2 – 2.5mm. Sometimes it is as thin as 1mm, but usually in a higher density, thus negating the thinness of the hatching in terms of easing air flow. The grill element of these cases is designed this way because these server cases use the grill metal as structural elements of the case. However, the thickness of the hatching in these grill designs severely retards air flow, badly affecting cooling efficiency.
- (b) Our design is to have separate structural elements akin to pillars in a building, that are outside of the critical cooling air flow, and to utilize non-structural, non-load bearing grill material that has very thin hatching, in the 0.1mm or less thickness range, in the areas of the case that in the critical path for intake and exhaust of cooling air, thereby substantially reducing the power needed to move cooling air through the case. This will decrease the amount of air that cooling fans have to push or pull through the system, thus reducing the overall amount of power consumed by the system.

VIII. TDP Server Testing Methodology

- (a) Total Design Power (the maximum amount of power the device can consume as long as it is operating in the manner it was designed) is important to server customers because it allows a well engineered design of the power distribution infrastructure and the HVAC provisioning in order to have a smooth running data center and high reliability and availability of the services the server is intended to provide. Accurate measurements of the TDP of a server are hard to find.
- (b) This testing methodology yields TDP results which are the most accurate attainable, and therefore the most valuable.
- (c) <Listing of the methodology>