



TCC 2013
 February 7th, 2013
 Santa Clara Convention Center
 Santa Clara, CA.

Exhibitor Information

Company Name			Booth #
Street Address			
City	State	Zip	Country
Ordered by		Email Address	
Telephone		Fax	

Please complete the above information and send this form with all orders. Fax to: 831-886-8686 Email to: casey@tricord.net

Show Information

Show Colors

Booth Drape: Blue, Silver, Gold, Silver, Blue

Exhibit Hall Carpet: Yes

Booths:

Gold Package

8' x 10' booth space includes:

- 8' High Back Drape
- 3' High Side Rails
- (1) 7"x44" ID Sign
- (1) 6' draped table-Gold
- (2) Side chairs
- (1) Waste Basket

Platinum Package

10x20' Booth Package Includes:

- 8' High Back Drape
- 3' High Side Rails
- (1) 7"x44" ID Sign
- (2) 6' Draped Tables-Gold
- (4) Side Chairs
- (2) Waste Baskets

Silver Package

Table Top Space Includes:

- 8' High Back Drape
- (1) 7"x44" ID Sign
- (1) 6' draped table-Blue
- (2) Side chairs
- (1) Waste Basket



TCC 2013
February 7th, 2013
Santa Clara Convention Center
Santa Clara, CA.

Deadlines

Rental Discount Deadline: January 4th, 2013

Advance Freight Receiving Deadline: February 4th, 2013

** All advance freight will be delivered to your booth space prior to exhibitor move in to expedite your set up.*

Exhibit Hall Hours

Exhibitor Move In

Wednesday February 6th 11:00am – 4:00pm

Exhibits Open

Thursday February 7th 7:30am – 7:00pm

Exhibitor Move Out

Thursday February 7th 7:00pm – 9:00pm

**Note: All exhibitor ordered freight carriers must be checked in by 8:00pm for freight pick up*

Move Out Information/Paperwork:

Move out is on Wednesday February 7th beginning at 7pm and ending at 9pm. BOLs will be available onsite or can be sent ahead of time to us. Please see the kit's I&D instructions and look at part 2 Outbound Shipping. All carriers must be checked in by 8pm.

Union Rules & Regulations

You can only bring in materials yourself they can be **brought in by one person in one trip**. If your materials weigh 200# or less we offer a **cartload service**. Anything over 200# requires the **material handling form**.

- You may NOT wheel in materials yourself.

Helpful Hints/Ways to Save:

Custom Booth Packages:

These packages will include all of the labor costs to install & dismantle the booth and saves you any shipping charges of sending your own booth to the show. These packages give you more opportunities to personalize your booths with graphics making it much more noticeable on the show floor

- *Please call if you are interested or contact Laurissa@tricord.net*

Custom Furniture Packages -Offers groups of furniture for a cheaper price than buying each item individually

- *This deal will not be available at this price the day of the show.*



Estimated Totals & Payment Form

Services Ordered	Totals
Material handling -----	\$ <input type="text"/>
Booth packages -----	\$ <input type="text"/>
Carpet -----	\$ <input type="text"/>
Furnishings -----	\$ <input type="text"/>
Labor -----	\$ <input type="text"/>
Electrical -----	\$ <input type="text" value="109.50"/>
Electrical Labor -----	\$ <input type="text"/>
Cleaning -----	\$ <input type="text"/>
Signage -----	\$ <input type="text"/>
Plants -----	\$ <input type="text"/>
Total: \$	<input type="text" value="109.50"/>

Credit & Payment Policies

- Payment must be included with all advance orders to obtain the discount rates.
- The exhibiting firm is ultimately responsible for payment or charges.
- All charges must be settled at our service desk prior to show closing.
- No credit or adjustments will be made after the close of the show.
- Any services not settled by close of the show are subject to a 25% service charge.

Should you have any questions regarding credit procedures, please contact:

TriCord
 738 Neeson Road
 Marina, Ca. 93933
 Phone: (831) 883-8600
 Fax: (831) 883-8686



Method of Payment

Company Check

- Please make checks payable to Tricord Tradeshows
 (Checks must be in U.S. Funds)
 Mail to:

Tricord Tradeshows
738 Neeson Road
Marina, CA 93933

Company Card

- Credit Card Information   

Submission of order forms subject exhibitors to Tricord's Limits of liabilities Policy

Account Number	5196 8400 0090 3130	Expiration Date:	12/15	CCID #	127
Cardholder Name	Andrew Sharp		Card Type:	MC	
Signature	A. Sharp	Print Name	Andrew Sharp		
Billing Address	212 Thompson Sq., Mountain View, CA 94043				
Telephone	650.906.9448	Fax			
Company Name:	Low Power Company, Inc.				



Shipping: Advance to Warehouse

Advance Shipment Deadline

Monday February 4th, 2013

Advance Crated Shipments

Advance crated shipments will be accepted at the Tricord warehouse and allowed (30) days free storage

All shipments must have a BOL or delivery slip showing the number of pieces, weight & type of merchandise.

***For tracing purposes, please send copies to the Tricord address & to the person in charge of installing your display**

Straight Time M-F 8am-4:30pm

Overtime:

Overtime is Monday through Friday prior to 8:00am-4:30pm; all day Saturday, Sunday and observed union holidays; after the deadline date.

If warehouse freight must be moved into the exhibit site on overtime due to scheduling conflict beyond the control of Exhibition Contractors

Shipments should be consigned and the bill of lading made out as follows:

Exhibiting Company Name	Booth#
TCC 2013	
Tricord Tradeshows	
738 Neeson Road	
Marina, CA. 93933	

Advance Shipment Rates (200lb min)

\$78.00

For each 100 lbs. or fraction thereof.

Overtime on Advance Shipments (200lb min)

\$22.00

For each 100 lbs. or fraction thereof.

*invoiced in addition to those rates on all shipments subject to overtime charges.

Important information

Shipments received without receipts, freight bills, or specified unit count 6 on receipts or freight bills (i.e. one lot 800 cu. ft., etc.), such as UPS or van lines, will be delivered to the exhibitor's booth without guarantee of piece count or condition. No liability will be assumed by for such shipments.

In the event no weight is indicated on the documents presented. Tricord shall estimate the weight and charges will be based on the estimates and such charges will not be subject to adjustment.



RUSH! EXHIBIT MATERIAL

MUST ARRIVE BY FEBRUARY 4th, 2013

TO: _____

(EXHIBITOR NAME)

BOOTH # _____

EVENT: _____ TCC 2013

TriCord Tradeshows
738 Neeson RD.
Marina, CA. 93933

WAREHOUSE

NO. _____ OF _____ PIECES



RUSH! EXHIBIT MATERIAL

CAN ONLY ARRIVE BY FEBRUARY 4th, 2013

TO: _____

(EXHIBITOR NAME)

BOOTH # _____

EVENT: _____ TCC 2013

TriCord Tradeshows
738 Neeson RD.
Marina, CA. 93933

WAREHOUSE

NO. _____ OF _____ PIECES



Shipping: Direct to Exhibit Site

Direct Shipments to the Exhibit Site

-Material will be unloaded from the exhibitor's carrier onsite, delivered to the exhibitor's booth & reloaded on a carrier at the rate listed on the right hand side.

Special Handling

-Shipment by any truck that cannot be unloaded at the docks (including moving vans)
-Shipments "packed" in a way that special handling is required (i.e. loose display parts; uncrated equipment, etc.)
-If material or equipment cannot be determined (i.e. 1 lot 20 assorted pieces, etc.)

Overtime

-After 4:30pm on weekdays; all day Saturday, Sunday; observed union holidays; after the designated dates & times on the right; Scheduling conflicts beyond the control of Tricord.

Outgoing Shipments

-Tricord Service Desk-located in the Exhibitor Service Center will have labels, BOLs, and shipping info available.
-At the close of the show, where carriers fail to pick up or refuse shipments, Tricord reserves the right to reroute shipments
-If no destination is provided, material may be taken back to the warehouse, at exhibitor's expense, pending advice from the exhibitor. No liability will be assumed by Tricord.

Important Information

If the bill of lading does NOT identify the weight of the various classifications, the entire shipment will be invoiced at the Special Handling rate and will not be subject to adjustment.

Payment

All accounts must be settled at the service desk prior to the close of the show unless advance credit approval has been obtained. A purchase order, if required for or payment, must accompany the order form(s). All of the materials are on a rental basis and remain the property of Tricord. [Payment for all labor and services, whether ordered by the exhibitor, display builders or other parties, shall be the responsibility of the exhibitor. Please make payments in U.S. Funds.](#)

Shipment must arrive:

Wed. Feb. 6th, 2013 Between 11am - 4pm

Shipments should be consigned and the bill of lading made out as follows:

Tricord Tradeshows Booth#
c/o Santa Clara Convention Center
5001 Great America Parkway
Santa Clara, CA 95054

Rates for Direct Shipments to Exhibit Site (200lb min)

\$80.00

For each 100 lbs. or fraction thereof

Overtime Rates & Special Handling

\$22.00

For each 100 lbs. or fraction thereof.

*invoiced in addition to those rates on all shipments subject to overtime charges.



RUSH! EXHIBIT MATERIAL

CAN ONLY ARRIVE ON FEBRUARY 6th, 2013

TO: _____
(EXHIBITOR NAME)

BOOTH # _____

EVENT: _____ TCC 2013

TriCord Tradeshows
c/o Santa Clara Convention Center
5001 Great America Parkway
Santa Clara, CA 95054

SHOWSITE

NO. _____ OF _____ PIECES



RUSH! EXHIBIT MATERIAL

CAN ONLY ARRIVE ON FEBRUARY 6th, 2013

TO: _____
(EXHIBITOR NAME)

BOOTH # _____

EVENT: _____ TCC 2013

TriCord Tradeshows
c/o Santa Clara Convention Center
5001 Great America Parkway
Santa Clara, CA 95054

SHOWSITE

NO. _____ OF _____ PIECES



Material Handling

Important Information

Note: We understand that your calculation is only an estimate. Your shipment will be invoiced based on the actual weight listed on the inbound bills of lading. Adjustments will be made accordingly.

If you have any questions about material handling, please contact our Customer Service Department listed below.

All of the materials are on a rental basis and remain the property of Tricord. Payment for all labor and services whether ordered by exhibitor, display builders or other parties, shall be THE RESPONSIBILITY OF THE EXHIBITOR. PLEASE MAKE PAYMENTS IN U.S. FUNDS.

Check One:

- We plan to ship our crated material to the Advance shipment Warehouse
 We plan to ship our materials direct to the exhibit site

Calculation of Order

****When calculating weight, round up to the next 100lbs. (example: 265 lbs=300lbs, 3 x rate= Dollars or Minimum**

Advance Crated Shipments to the Warehouse (200 lb minimum)

We will ship lbs. @ per 100 lbs = minimum =

Direct Crated Shipments to the Exhibit Site (200 lb minimum)

We will ship lbs. @ per 100 lbs = minimum =

Shipments or Equipment Requiring Special Handling at the Exhibit Site

We will ship lbs. @ an additional \$21.00 cwt. each way minimum =

Overtime Charges (200 lb. Minimum)

(See overtime charges on Shipping Instruction Order Form)

per 100 lbs = minimum =



Authorization to Provide Material Handling Services

We hereby authorize Tricord to provide such services as necessary to handle our shipment(s) in accordance with the information set forth in the "LIMITS OF LIABILITY AND RESPONSIBILITY" above and we further agree to the following:

- We have examined and reviewed the "Material Handling Classification and Rates" page which were forwarded to our firm and understand we will be charged for Material Handling Services in accordance with the published rates for such services as are provided.
- We accept the responsibility for the payment of all the Tricord charges in connection with the handling of our shipment(s) and we guarantee payment to Tricord in the event any third party who acts in our behalf shall fail to pay such charges within thirty (30) days of the receipt of the Tricord invoice for such charges.
- We agree to Tricord "Limits of Liability and Responsibility" as set forth above.
- We agree that Tricord, or its subcontractors', liability shall be limited to any loss or damage which results solely from Tricord or its subcontractors', NEGLIGENCE the actual physical handling of the items comprising our shipment(s) and not for any other type of loss or damage.
- With particular reference to paragraphs "c" and "d" above, we agree in connection with the receipt, handling, and temporary storage and reloading of our materials that Tricord and its subcontractors, will provide their services as our agent, and not as bailee or shipper. If any employee of Tricord, or its subcontractors, shall sign a delivery receipt bill of lading or other documents we agree that Tricord, or its subcontractors, will do so as our agent and we accept the responsibility therefore. (1) Relative to inbound shipments, we recognize that there may be a lapse of time between the delivery of our shipment(s) to our booth by Tricord subcontractors, and the arrival of our representative at the booth and during such time our shipment(s) will be unattended in our booth. We agree that Tricord and its subcontractors shall not be responsible for any loss or damage which may occur during such period.
- (2) Relative to outgoing shipments, we recognize that there will be a lapse of time between the completion of packing and the actual pickup of our materials from our booth for loading onto a carrier, and during such time our shipment(s) will be left unattended in our booth. We agree that Tricord, and its subcontractors, shall not be responsible for any loss or damage which may occur during such period, and we authorize Tricord or its subcontractors, to adjust the quantities of times on any bill of lading submitted by us to Tricord or its subcontractors, to conform to the actual count of such items in the booth at the time of pickup.
- We agree, in the event of a dispute with Tricord, or its subcontractors, relative to any loss or damage to any of our materials or equipment, that we will not withhold payment of any amount due to Tricord for material handling service or any other services provided by Tricord, or its subcontractors, as an offset against the amount of the alleged loss or damage. Instead, we agree to pay Tricord thirty (30) days from the close of the show for all such charges and further agree that any claim we may have against Tricord, or its subcontractors, will be pursued independently by us as a completely separate transaction to be resolved on its own merits.
- In order to expedite removal of materials from the show site, Tricord shall have the authority to change designated carriers, as such carriers do not pick up on time. Where no disposition is made by the Exhibitor, materials will be taken to a warehouse to wait the Exhibitor's shipping instructions and we agree to pay for charges relating to such handling at the warehouse.
- We agree that all questions relating to classification freight of the Exhibitor's materials, rates charged or weights used to determine material handling charges shall be submitted to the Tricord office indicated on the invoice thirty (30) days of the receipt of the invoice. Complaints received after such period shall not be considered and payment of the invoice shall be made in full.

Company Name	Booth Number
Signature	Date

Limits of Liability & Responsibility

- Tricord, and its subcontractors, shall not be responsible for damage to uncrated materials, materials improperly packed, glass breakage or concealed damage.
 - Tricord, and its subcontractors are not, and cannot be, responsible for loss or disappearance of the Exhibitors materials after same have been delivered to the Exhibitor's booth.
 - Similarly, Tricord and its subcontractors cannot be responsible for the disappearance of the Exhibitor's materials before the materials are picked up from the Exhibitor's booth for loading out after the show. All bills of lading covering outgoing shipments, which are given to Tricord by the Exhibitor's, will be checked at the time of pickup from the booth and corrections made where discrepancies exist.
 - Tricord, and its subcontractors, shall not be responsible for loss, delay or damage due to strikes, lockouts or work stoppages of any kind.
 - Tricord and its subcontractors shall not be responsible for ordinary wear and tear in handling of equipment, nor for loss or damage due to fire, theft, windstorm, water, vandalism, acts of God, mysterious disappearance or other causes beyond its control.
 - Tricord and its subcontractors shall not be held liable for any damage incurred during the handling of equipment requiring special devices to properly load, place or reload unless advance notice has been given to Tricord in time to obtain the proper equipment.
 - It is understood that Tricord, and its subcontractors, are not insurers. Insurance if any shall be obtained by the Exhibitor and that the amounts payable to Tricord hereunder are based on the value of the material handling services and the scope of the liability as herein set forth and are unrelated to the value of the Exhibitor's property being handled. Since it's impractical and extremely difficult to fix the value of each shipment handled by Tricord, or as subcontractors, it is understood that Tricord, and its subcontractors, do not provide for full liability should loss or damage occur. It is agreed that if Tricord, or its subcontractors, should be found liable for loss or damage due to a failure to properly handle the Exhibitor's equipment, the liability shall be limited to the specific article which was physically lost or damaged and such liability shall be limited to a sum equal to \$.25 per pound per article with a maximum liability of \$50.00 per item, or \$1,000.00 per shipment whichever is less, as agreed upon damages and not as a penalty, as the exclusive remedy: and that provisions of this paragraph shall apply if loss or damage irrespective of cause or origin, results directly or indirectly to property from performance or nonperformance of obligations imposed by the offering of material handling services to exhibitors or from negligence, active or otherwise, of Tricord, its subcontractors or employees.
- Tricord, and its subcontractors, shall not be liable to any extent whatsoever for any actual, potential or assumed loss of profits or revenues or for any collateral costs, which may result from any loss or damage to an Exhibitor's materials which may make it impossible or impractical to exhibit same.
 - Claims for loss or damage which are not submitted to Tricord within thirty (30) days of the close of the show on which the loss or damage occurred shall be considered waived. No suit or action shall be brought against Tricord, or its subcontractors, more than one (1) year after the action of the cause of action therefore.
 - The consignment or delivery of a shipment to Tricord, or its subcontractors, by an Exhibitor, or by any shipper on behalf of the Exhibitor shall be construed as an acceptance by such Exhibitor (and/or other shipper) of the terms and conditions set forth in Sections 1 thru 9.
- **BE SURE YOUR MATERIALS ARE INSURED from the time they leave your firm until they are returned after the show. It is suggested that Exhibitors arrange all risk coverage. This can usually be done by "riders" to existing policies. Contact your insurance representative.**
 - **BE SURE YOUR LIABILITY INSURANCE is in effect at the show site. Contact your insurance representative.**



Display Installation & Dismantling

Service A-Tricord Supervision

Installation

We would like our display unpacked and installed under Tricord supervision prior to our arrival at the exhibit site. We are forwarding blueprints, a photo or instructions and shipping information to you shortly and you will immediately contact our representative for instructions in the event of shortages in shipment or damage. We understand that all work will be done on straight time where possible. We understand a supervision service charge will be added to our bill of labor furnished at the above rate. **Supervision service charge (25% of total I&D)**

Dismantling

We would like our display dismantled and packed under Tricord Supervision. We will leave instructions for shipping, address and waybill at the Service Center before the end of the show. We understand the supervision service charge will apply. An additional surcharge will be applicable when displays are dismantled under Tricord Supervision when no installation labor is provided under Tricord Supervision. **Supervision service charge (25% of total I&D)**

Service B- Exhibitor Supervision

We would like man (men) available to unpack and install our display under the supervision of our representative on (date) at (time) am/pm for approximately hour(s).

We would like man (men) available to dismantle and pack our display under the supervision of our representative on (date) at (time) am/pm for approximately hour(s).

Please confirm Dismantling Labor at the exhibit site and allow time for return of any empty crates and containers.

Note: If the exhibitor fails to pick up the man (men) at the time confirmed, a one (1) hour charge per man "NO SHOW CHARGE" will be incurred.

The exhibitors representative will return the crew to the Service Center upon completion of the work, check the work order and approve the work order by signing.

Display labor

- Straight Time- 8:00am-4:30pm, Monday-Friday
 \$ **99.00/per man/per hour** Discount Rate
 \$ **127.00/per man/per hour** Floor Order
- Overtime- Before 8:00am & after 4:30pm weekdays and all day Saturday, Sunday, & Holidays
 \$ **165.00/per man/per hour** Discount Rate
 \$ **189.00/per man/per hour** Floor Order

	Date & Time	# of Men	# Hours	Hourly Rate	Total
Installation	<input type="text"/>	x <input type="text"/>	x <input type="text"/>	x <input type="text"/>	= <input type="text"/>
	<input type="text"/>	x <input type="text"/>	x <input type="text"/>	x <input type="text"/>	= <input type="text"/>

	Date & Time	# of Men	# Hours	Hourly Rate	Total
Dismantle	<input type="text"/>	x <input type="text"/>	x <input type="text"/>	x <input type="text"/>	= <input type="text"/>
	<input type="text"/>	x <input type="text"/>	x <input type="text"/>	x <input type="text"/>	= <input type="text"/>

Total: \$



Outbound Shipping

Outbound Shipping Instructions

Please complete this section if Tricord will be supervising booth labor

Select Carrier/Shipping Method ➡

Exhibitor Outbound Shipping Instructions: At close of show, exhibitor freight will be shipped to the following address. If your freight is being forwarded to another show be sure to include the name of show and your booth number.

Company Name		Booth #	
Street Address			
City	State	Zip	Country
Attention:			

Select Shipping Carrier

Ship Via carrier of exhibitor's choice. *(Exhibitor Must Schedule pick up with carrier)*

Name of Carrier ➡

Ship Via carrier of official show freight carrier

Select Shipping Method

Ground

Air: Select Service Preferred

Please note:

- If an exhibitor is using a carrier of his/her own choice (or not using the **official** show freight carrier), the exhibitor is responsible for arranging for carrier to pick up at the close of the show.
- Tricord cannot guarantee pick up time for exhibitor appointed carriers. All shipments are moved out of the exhibit hall at Tricord's discretion.

Billing Information

Please indicate billing information for carrier charges if different from above listing

Bill Shipping Charges to (if different from above)

Shipper (signature)		Shipper (print name)	
Freight Charges Billed to (Company/Show)			
Address:			
City	State	Zip	Country
Telephone		Attention:	
Shipping Account Number:			



Union Rules & Regulations

Union Information

To assist you in planning your participation in your Santa Clara area show, we are certain you will appreciate knowing in advance that union labor will be required for certain aspects of your exhibit handling.

Decorator's Union

Members of this union claim jurisdiction over all set up and dismantling of exhibits including signs and laying of carpet. This does not apply to the unpacking and placement of your merchandise. You may set up your exhibit display if one person can accomplish the task in less than one-half (1/2) hour without the use of tools. If your exhibit preparation, installation or dismantling requires more than one-half (1/2) hour, or exceeds ten feet you must use union personnel supplied by the Official Decorating Contractor. As an exhibitor, you will be pleased to know that when union labor is required, you may provide your company personnel to work along with a union installer in Santa Clara on a one-to-one basis.

Teamsters Union

Members of this union claim jurisdiction on the operation of all material handling equipment, all unloading and reloading and handling of empty containers. An exhibitor may move materials that can be carried by hand, by one person in one trip, without the use of dollies, hand trucks or other mechanical equipment.

Electrical Union

Members of this union claim jurisdiction for hardwiring ordered outlets to the line side of the exhibitors' equipment and wiring of caps over 120 volts, to the raw cord feeding exhibitors' equipment. All plugs over 120 volts will be plugged in by electrical union personnel. Exhibitors may plug in their own plugs of 120 volts to their ordered outlets.

Tipping

Our work rules prohibit the Solicitation and/or acceptance of tips by any of our employees. Our employees are paid excellent hourly wages, denoting a professional status and tipping is not allowed.



Third Party Authorization

Important Information

You may arrange for a third party to handle your display and be charged for services.

**Tricord Tradeshows will agree to this arrangement if the third party has a credit card on file.

Both firms must complete this form, including **Third Party Credit Card Charge Authorization** below, & **Return form by the deadline date of Friday May 4th, 2012.**

It is understood and agreed that the exhibiting firm is ultimately responsible for payment of charges. If your named third party does not pay the invoice before the last day of the show, charges will revert to you, the exhibiting firm. All invoices are due and payable upon receipt.

Exhibiting Company Authorization of Third Party Billing

Exhibitor Name:	Date:
Exhibitor Signature:	

Exhibiting Firm

Company Name			Booth #
Street Address			
City	State	Zip	Country
Ordered by		Email Address	
Telephone		Fax	

Third Party

Company Name			Booth #
Street Address			
City	State	Zip	Country
Signature		Print Name	
Telephone		Fax	

Third Party Credit Card Authorization



Account Number	Expiration Date:	CCID #
Cardholder Name		Card Type:
Signature		Print Name
Telephone	Fax	



EXHIBITORS ONLY-EAC INFORMATION FORM

If an exhibitor plans to use a firm other than the "official Show Vendor" please list below the non-official vendor's company name, contact name, phone number and email. After completing this form please fax it to TriCord Tradeshows at the number listed below. The **Exhibitor Appointed Contractor Information Form** must be completed and returned no later than **Wednesday January 4th, 2013.**

After completing this form please give each of your non-official vendors one of the following appropriate forms.

- The Contractors-I&D EAC Form (for installing or dismantling booths) or
- Contractors-EAC form (all other vendors including AV, internet, booth designer etc.)
- A copy of the Exhibitor Appointed Contractor certificate of insurance with a minimum of \$1,000,000.00 liability coverage, including property damage, to show management and TriCord Tradeshows at least 10 days before the show opening.

**** Please note that an EAC form is not required from exhibitors who plan to set up & dismantle their own booth with their own full-time bonafide employees.**

**** All EAC's must be aware of and abide by all union rules & regulations**

Company Name	Booth #
Street Address	
Ordered by	Email Address
Telephone	Fax

Exhibitor Appointed Contractor Information

Please list below your exhibitor appointed contractors information:

Company	Contact Name	Phone	Email
1. _____	_____	_____	_____
2. _____	_____	_____	_____
3. _____	_____	_____	_____
4. _____	_____	_____	_____
5. _____	_____	_____	_____

Please fax or mail this form to TriCord Tradeshows by: January 4th, 2013

10x10 CUSTOM BOOTH RENTALS

No Shipping Costs! No Drayage! Turnkey Setup!
Ready When You Arrive! Installation Included!

Package #1

- 10' Hardwall Backwall
- Matching Carpet
- Two Lights (Electricity Required)
- Color Options:
Black White Gray Blue
- Package Pricing \$ 1050.00**
(25% off listed prices)

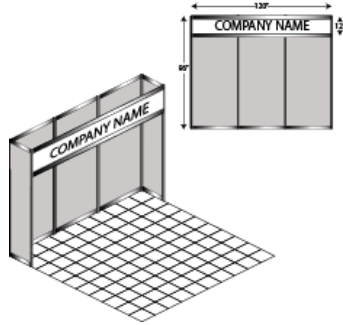

Package #2

- 10' Hardwall Back wall
- 1 Meter Counter
- Matching Carpet
- Two Lights (Electricity Required)
- Color Options:
Black White Gray Blue
- Package Pricing \$ 1250.00**

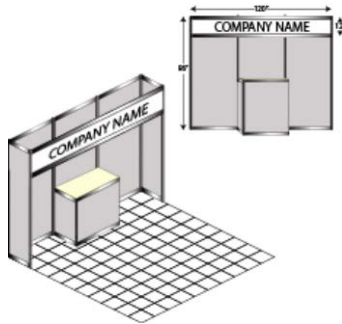

Package #3

- 10' Hardwall Backwall
- (2) ½ meter counters
- Curved Header
- Matching Carpet
- Shelves not Available*
- Two Lights (Electricity Required)
- Color Options:
Black White Gray Blue
- Package Pricing \$ 1450.00**

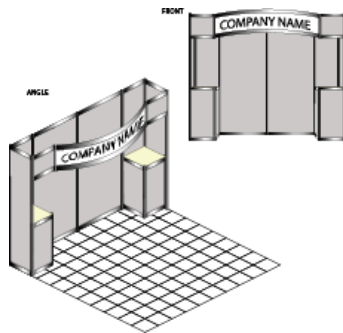

Package #4

- Tabletop Backwall
- One Stem Light (Electricity Required)
- Package Pricing \$ 600.00**
(8' table is required)



Package #5

- Velcro Compatible Pop-up Booth
- 8' High x 10' Wide
- Black Only
- Two Stem Lights (Electricity Required)
- Carpet Not Included
- Package Pricing \$ 800.00**
- W/Full Color Header \$950.00

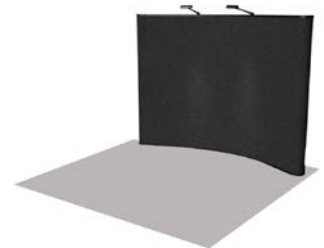

Additional Options

Custom Graphics for Backlit Headers:
(10 days advance ordering required)

<input type="checkbox"/> Black & White Header	x	\$150.00	-----	\$	<input type="text"/>	Total
<input type="checkbox"/> Color Print w/ Logo	x	\$200.00	-----	\$	<input type="text"/>	
Header Copy to Read:						<input type="text"/>
<input type="checkbox"/> Will Send Artwork						

Options:

Matching Counters/Pedestals

	Price	Quantity	Total
<input type="checkbox"/> Pedestal	-----\$140.00	x <input type="text"/>	-----\$ <input type="text"/>
<input type="checkbox"/> 1 m Cntr	-----\$280.00	x <input type="text"/>	-----\$ <input type="text"/>
<input type="checkbox"/> 2 m Cntr	-----\$325.00	x <input type="text"/>	-----\$ <input type="text"/>
<input type="checkbox"/> 1 m Cntr (Curved)	-----\$290.00	x <input type="text"/>	-----\$ <input type="text"/>

Add Custom Graphics to Counters:

	Price	Quantity	Total
<input type="checkbox"/> 1 m Cntr	-----\$170.00	x <input type="text"/>	-----\$ <input type="text"/>
<input type="checkbox"/> 2 m Cntr	-----\$320.00	x <input type="text"/>	-----\$ <input type="text"/>
<input type="checkbox"/> Add doors (Cntr)	-----\$60.00	x <input type="text"/>	-----\$ <input type="text"/>
<input type="checkbox"/> Add shelves (Back wall)	\$25.00	x <input type="text"/>	-----\$ <input type="text"/>

*Doors & Shelves not available for pedestal

Total: \$

10x20 CUSTOM BOOTH RENTALS

*No Shipping costs! No Drayage! Turnkey Setup!
Ready When You Arrive! Installation Included!*

Package # 6

20' Hardwall Backwall
(1) Meter Counter
10x20 Carpet
Two Lights (electricity required)
Black **White** **Gray** **Blue**
Package Pricing \$ 1895.00

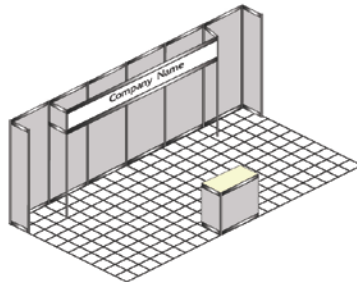
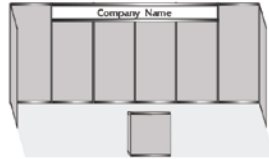

Package # 7

20' Hardwall Backwall
(1) Meter Counter
(2) Meter Shelves
10x20 Carpet
Two Lights (electricity required)
Black **White** **Gray** **Blue**
Package Pricing \$ 2095.00

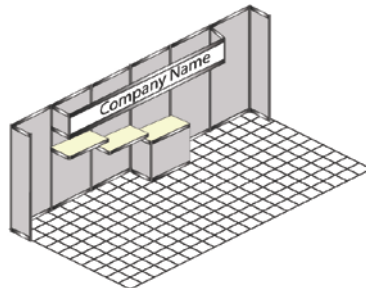

Package # 8

20' Curved Hardwall Backwall
(3) Double Curve Counters
10x20 Carpet
Four Lights (electricity required)
Black **White** **Gray** **Blue**
Package Pricing \$ 2895.00
**Graphics Optional*

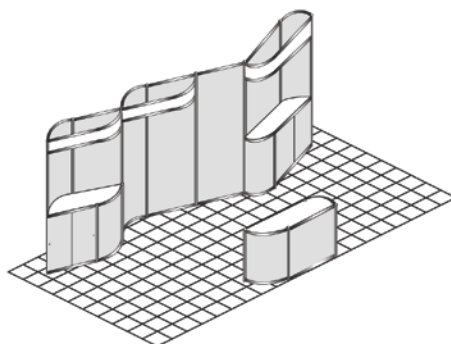

Package # 9

20' Zig Zagged Hardwall Backwall
(2) Built in Counters W/doors in front
(2) Shelves
(1) Free Standing Curved Meter Counter
10x20 Carpet
Two Lights (electricity required)
Black **White** **Gray** **Blue**
Package Pricing \$ 2695.00

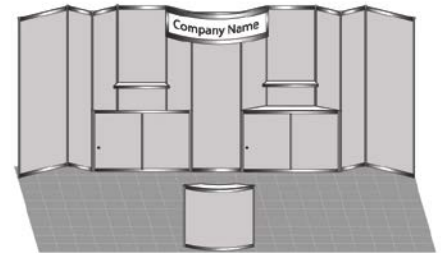

Package # 10

20' Hardwall Backwall W/Horizontal Panels
(2) Built in 2 Meter Counters
10x20 Carpet
Four Lights (electricity required)
Black **White** **Gray** **Blue**
Package Pricing \$ 2395.00

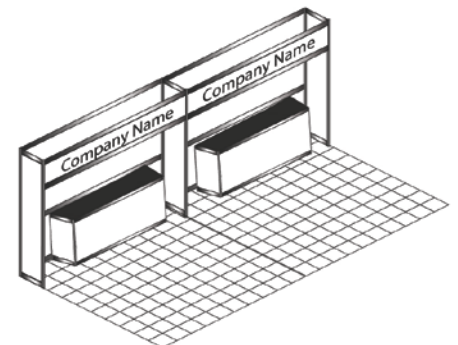

For Booth Header & Additional Options refer to previous page.

**** Full Graphics are available**



Signs & Banners

TriCord produces full color digital prints mounted on sign board or banner material. We can mount your sign to your display, hang it overhead or place it on a stand. We will print your art or help create custom signage. Send disk or Email all artwork and logos to signs@tricord.net for quotes, design and proofing. Save files as vector .PDF or .EPS, 300 dpi for photos. FTP is available for large files.

Standard Size Signs

*Fits in Sign Holder **Custom booth back wall panel

Sizes	Quantity	Cost	Total
*22" x 28"-----	<input type="text"/>	x \$60-----	\$ <input type="text"/>
24" x 36"-----	<input type="text"/>	x \$85-----	\$ <input type="text"/>
30" x 40"-----	<input type="text"/>	x \$120-----	\$ <input type="text"/>
36" x 48"-----	<input type="text"/>	x \$175-----	\$ <input type="text"/>
36" x 60"-----	<input type="text"/>	x \$220-----	\$ <input type="text"/>
**38" x 94"-----	<input type="text"/>	x \$375-----	\$ <input type="text"/>
Total: \$			<input type="text"/>

We will send ready to print artwork

We require design assistance

-Please give us a general idea of what you are looking for below

Draw your sign. Please specify copy and indicate PMS colors, fonts, materials, size, orientation, etc.

Standard Size Banners

*Includes Grommets or Sleeve for rod

Sizes	Quantity	Cost	Total
2' x 6'-----	<input type="text"/>	x \$180-----	\$ <input type="text"/>
2' x 8'-----	<input type="text"/>	x \$240-----	\$ <input type="text"/>
3' x 6'-----	<input type="text"/>	x \$270-----	\$ <input type="text"/>
2' x 10'-----	<input type="text"/>	x \$300-----	\$ <input type="text"/>
3' x 8'-----	<input type="text"/>	x \$360-----	\$ <input type="text"/>
3' x 10'-----	<input type="text"/>	x \$450-----	\$ <input type="text"/>
Total: \$			<input type="text"/>

Custom Size Sign Options:

Color prints on gloss-----\$15 per square foot

Mount on Sintra-----\$3 per square foot

Graphic Design Time-----\$95 per Hour

-**Deadline Date:** 10 days prior to exhibition

-Orders submitted after are subject to a 25% late fee

-**Cancellation Policy:** Signs cancelled or changed after order is received will be charged original price

Special Instructions:

Total of all Signs Ordered	\$
Set Up Fee	\$ 25.00
Add 25% late charge (if applicable)	\$
Rush Fee (if applicable)	\$

Total Amount Enclosed \$

Digital File Preparation

We want your graphics and images to look their best. In order to insure the best quality of graphics and images from your digital files, and to make file transfers as easy and seamless as possible, please follow these guidelines for submission of your artwork to Graphics Production. If you are unable to provide digital artwork for your signage needs, we are capable of providing you with layout services. Additional fees will apply. Please contact TriCord for details.

Suitable Formats for images and/or logos

Program	Preferred Format
Adobe Illustrator CS5	.ai, .eps, .pdf (press quality)
Adobe Photoshop CS5	.pdf (press quality), jpeg (high res.)
Adobe InDesign CS5	InD (include all links)
Adobe Acrobat	PDF (press quality)

-All fonts must be converted to outlines-

Suitable Media for images and/or logos

Media	Preferred Format
Email Attachments	Limited to max size of 10MB
FTP	See info below
CD-ROM or DVD-ROM	Send hard copy color proofs

AVOIDING ADDITIONAL COSTS

Files obtained from the internet (.jpg or .gif) or artwork created in MS Office applications (Word, PowerPoint, Publisher, Excel, etc.) are not suitable for high quality output, and require additional hourly charges. Artwork should be created at actual size, however, if you have a very large file please contact us for options. To avoid any additional costs. Please send files using the guidelines below.

Vector Artwork

For the best quality, artwork should be created in vector format (.ai or vector .eps) Logos taken from websites are generally .gif files. These files are not acceptable as they will not print clearly.

See Visual

* All fonts within artwork need to be converted to outlines

PDF

Artwork that is created in almost any design program can be saved as or exported to a .pdf. When doing so the press quality setting must be used and all fonts must be converted into outlines. Artwork must be set to the proper proportions @100 of final size. Any images in the file must be saved as high resolution (300dpi) These steps will ensure good quality printing.

See Visual

JPEG

We will accept this file type, but only if it is used to compress a file for ease of sending, the original artwork should have been created high resolution 300dpi or vector format in order to print at the best possible quality.

See Visual

Vector Artwork Example:



.gif @ 400%



.ai / .eps vector @ 400%

PDF & JPG Example:



Low Resolution (72dpi) .jpg 23KB



High Resolution (300dpi) .jpg 3.1MB



FTP (File Transfer Protocol) Instructions

The FTP host address: ftp://207.111.210.13

User Name: tricorduser

Password: shows

Only upload your graphic once you have a confirmed order from signs@tricord.net

File Name: Show name, Co. Name & Booth #

Email signs@tricord.net when your upload is complete.

Cartload Service Order Form

Small Freight Service Qualifications

- This service is for exhibitors who have **small hand carry items**.
- All items must fit on a 3'x4' push cart, in one trip only.
- A cartload is eight (8) pieces or less, with a total weight of 200 lbs. or less. One cartload will be allowed per booth.

**** Exhibitors may not use carts without signed authorization from a TriCord account manager**

VEHICLES THAT QUALIFY:



Sedan



Van



Sports Utility Vehicle



Pickup

Failure to Qualify

- If you arrive with a **rental truck, trailer, personal truck, or bobtail** full of exhibit material, you will not qualify for this service and will be charged the standard direct drayage rates.
- Freight that is **too large** for one cart or has a total weight of **more than 200lbs** will be charged direct drayage rates.

VEHICLES THAT DO NOT QUALIFY:



Rental Truck



Flatbed



Stakebed



Trailers



Bobtail



Semi Truck

How to Receive Service Onsite

- Go to either the facility's main entrance or dock and ask about or look for the cartload service area.
- You may also order this service at the TriCord exhibitor services desk on the show floor.

Where to Load and Unload

- Your vehicle must be unloaded / loaded in the cartload service area which will be marked with signs.
- Carts are not authorized to enter or go to any parking structure.
- There must be two (2) people with the vehicle;** one person to go with your items to your booth, and one person to remove your vehicle from the unloading / loading area.

Small Freight Services

To assist with the move-in and move out of Exhibitors with small amounts of exhibit materials, TriCord Tradeshow Services is pleased to offer, one (1) laborer with one (1) pushcart, for one (1) trip at the costs listed below:

<u>Dock to Booth</u>	Price	Quantity	Total
One way service	\$55.00	x <input type="text"/>	-----\$ <input type="text"/>

<u>Booth to Dock</u>	Price	Quantity	Total
One way service	\$55.00	x <input type="text"/>	-----\$ <input type="text"/>

Total: \$

Authorized Signature: _____

Print Name: _____



Furniture Rental Form

Chairs	Quantity	Discount Rate	Standard Rate	Total
Side Chairs-----	<input type="text"/>	x \$ 30	x \$ 45-----	\$ <input type="text"/>
Padded Arm Chairs-----	<input type="text"/>	x \$ 50	x \$ 65-----	\$ <input type="text"/>
Black Leather Exec. Chairs-----	<input type="text"/>	x \$ 100	x \$ 115-----	\$ <input type="text"/>
Padded Bar Stools-----	<input type="text"/>	x \$ 65	x \$ 80-----	\$ <input type="text"/>

Tables 30" High	Quantity	Discount Rate	Standard Rate	Total
4' Draped Table-----	<input type="text"/>	x \$ 75	x \$ 90-----	\$ <input type="text"/>
6' Draped Table-----	<input type="text"/>	x \$ 85	x \$ 95-----	\$ <input type="text"/>
8' Draped Table-----	<input type="text"/>	x \$ 95	x \$ 125-----	\$ <input type="text"/>
Undraped 4' Table-----	<input type="text"/>	x \$ 60	x \$ 80-----	\$ <input type="text"/>
Undraped 6' Table-----	<input type="text"/>	x \$ 70	x \$ 90-----	\$ <input type="text"/>
Undraped 8' Table-----	<input type="text"/>	x \$ 80	x \$ 100-----	\$ <input type="text"/>

Color Selection → Blue Yellow White Black Burgundy Green Red

Counters 42" High	Quantity	Discount Rate	Standard Rate	Total
4' Draped Counter-----	<input type="text"/>	x \$ 90	x \$ 110-----	\$ <input type="text"/>
6' Draped Counter-----	<input type="text"/>	x \$ 100	x \$ 125-----	\$ <input type="text"/>
8' Draped Counter-----	<input type="text"/>	x \$ 105	x \$ 135-----	\$ <input type="text"/>
Undraped 4' Counter-----	<input type="text"/>	x \$ 75	x \$ 95-----	\$ <input type="text"/>
Undraped 6' Counter-----	<input type="text"/>	x \$ 85	x \$ 105-----	\$ <input type="text"/>
Undraped 8' Counter-----	<input type="text"/>	x \$ 95	x \$ 115-----	\$ <input type="text"/>

Color Selection → Blue Yellow White Black Burgundy Green Red

Table Risers	Quantity	Discount Rate	Standard Rate	Total
4' Risers-----	<input type="text"/>	x \$ 35	x \$ 50-----	\$ <input type="text"/>
6' Riser-----	<input type="text"/>	x \$ 60	x \$ 75-----	\$ <input type="text"/>
8' Riser-----	<input type="text"/>	x \$ 100	x \$ 115-----	\$ <input type="text"/>

Color Selection → Blue Yellow White Black Burgundy Green Red

Accessories	Quantity	Discount Rate	Standard Rate	Total
Waste Basket w/ Liner-----	<input type="text"/>	x \$ 12	x \$ 18-----	\$ <input type="text"/>
Easel-----	<input type="text"/>	x \$ 35	x \$ 45-----	\$ <input type="text"/>
Bistro Table-----	<input type="text"/>	x \$ 110	x \$ 140-----	\$ <input type="text"/>
Velcro Tack Board-----	<input type="text"/>	x \$ 95	x \$ 125-----	\$ <input type="text"/>
Glass Showcase-----	<input type="text"/>	x \$ 275	x N / A-----	\$ <input type="text"/>
Round Conf. Table-----	<input type="text"/>	x \$ 90	x \$ 110-----	\$ <input type="text"/>
4 th Side Table, Skirted/Drape Color Change-----	<input type="text"/>	x \$ 15	x \$ 25-----	\$ <input type="text"/>
5-Panel Literature Rack-----	<input type="text"/>	x \$ 85	x \$ 105-----	\$ <input type="text"/>
Bag Tree-----	<input type="text"/>	x \$ 45	x \$ 65-----	\$ <input type="text"/>

Furniture Total: \$

Custom Furnishing Packages

(Pre-Orders Only)



Conference Table



Bar Stool



Skirted Counter



Bistro Table

Important Information

These furniture packages are created to save YOU money

- Each group of furniture adds up to a cheaper price than buying each item individually
- This deal will not be available at this price the day of the show.

Package 1

Price- \$ 220

- 3 Arm Chairs
- 1 Round Conference Table (40")

Quantity-----

Package 2

Price- \$ 240

- 3 Bar Stools
- 1 Bistro Table (30")

Quantity-----

Package 3

Price- \$ 125

- 1 6' Draped Counter
- 1 Bar Stool

Quantity-----

Total \$



Electrical Services

- Labor is required for: All under-carpet distribution of electrical wiring, all overhead distribution of wiring & all hardwiring motor installation will require electrical labor. **(1 hour minimum install, ½ hour minimum dismantle)**
- ATTACH DIAGRAMS TO ENSURE ADVANCED PLACEMENT OF WIRING

Electrical Outlets

(Watts Required (120v Single Phase))	Discount	Floor Order		# Outlets Required	Total Due
500 Watts (5 amps) or less-----	\$109.50	\$152.00	x	<input type="text" value="1"/>	\$ <input type="text" value="109.50"/>
1200 Watts (10 amps) or less -----	\$170.50	\$209.00	x	<input type="text"/>	\$ <input type="text"/>
2400 Watts (20 amps) or less -----	\$247.50	\$308.00	x	<input type="text"/>	\$ <input type="text"/>
3000 Watts (30 amps) or less -----	Call for quote		x	<input type="text"/>	\$ <input type="text"/>
Total:					\$ <input type="text" value="109.50"/>

Lighting

(Electrical not included for spots)	Discount	Floor Order		Quantity	Total Due
300 Watts Halogen Stem Light-----	\$50.00	\$60.00	x	<input type="text"/>	\$ <input type="text"/>
300 Watt Floodlight on stanchion-----	\$90.00	\$125.00	x	<input type="text"/>	\$ <input type="text"/>
Extension Cord-----	\$20.00	\$20.00	x	<input type="text"/>	\$ <input type="text"/>
Plugstrip -----	\$20.00	\$20.00	x	<input type="text"/>	\$ <input type="text"/>
Total:					\$ <input type="text"/>

Motor/Power Requirements

	208 Single Phase	208/120v 3 Phase	Total Due
<input type="text"/> 10 Amps or ½ HP	<input type="text"/> \$302.50	<input type="text"/> \$385.00-----	\$ <input type="text"/>
<input type="text"/> 20 Amps or 2 HP	<input type="text"/> \$429.00	<input type="text"/> \$550.00-----	\$ <input type="text"/>
<input type="text"/> 30 Amps or 3 HP	<input type="text"/> \$550.00	<input type="text"/> \$704.00-----	\$ <input type="text"/>
Total:			\$ <input type="text"/>

Electrical Labor

Electrical drops are placed in the back center of the booth for no additional labor cost.

	Hours	Total Due
Straight Time	<input type="text"/> @ \$80.00 per hour-----	\$ <input type="text"/>
Overtime	<input type="text"/> @ \$150.00 per hour-----	\$ <input type="text"/>

Electrical Services Total: \$

- All motors over one (1) HP must have a Magnetic Starter and Manual Disconnect Switch (wired) furnished by the exhibitor.
- All wiring, motors, electrical installations, etc., will be inspected. To prevent overloading of circuits, exhibitors shall not be permitted to add wattage, except upon ordering same.
- Special electrical hook-ups or wiring incurring additional electrical labor charge must be taken care of prior to the close of the show.
- Price includes two (2) connections per outlet box for lighting and one (1) connection for power and motors. Additional outlets or power needed must be ordered through Tricord.
- Exhibitors found using power where no outlets have been ordered are subject to 1 ½ times normal rate for outlets used.



Booth Electrical Layout

- Electrical drops are placed in the back center of the booth for no additional labor cost.
- If you would like the electrical drop to be placed elsewhere in the booth, please mark the locations and wattage amounts on the grid below. Labor charges will apply.

Adjacent Booth or Aisle Number: _____

Adjacent Booth or Aisle Number: _____

Adjacent Booth or Aisle Number: _____

Adjacent Booth or Aisle Number: _____



Carpet Rental Form

Standard Cut Carpet

- Prices include installation and taping of front edge only. Additional taping at \$.75 per foot must be ordered if booth space has more than one entrance/exit point.

Carpet Size	Quantity	Discount Rate	Standard Rate	Total
<input type="checkbox"/> 8 x 10	<input type="text"/>	\$ 125.00 x	\$ 150.00	\$ <input type="text"/>
<input type="checkbox"/> 8 x 20	<input type="text"/>	\$ 250.00 x	\$ 275.00	\$ <input type="text"/>
<input type="checkbox"/> 8 x 30	<input type="text"/>	\$ 375.00 x	\$ 425.00	\$ <input type="text"/>
<input type="checkbox"/> 8 x 40	<input type="text"/>	\$ 500.00 x	\$ 550.00	\$ <input type="text"/>

Color Selection →  Blue Toast Gray Black Burgundy Green Red

Padding

Booth size: x = Sq. Ft. @ \$.80 SQ Ft. = \$

Additional Taping

Booth size: x = Sq. Ft. @ \$.75 SQ Ft. = \$

Visqueen

Booth size: x = Sq. Ft. @ \$.35 SQ Ft. = \$

Total: \$

Special Cut Carpet & Island Booths

- Must be ordered in 10' increments (Minimum of 100 square feet)
Example: 10x20 booth= 200sq. ft X \$2.75 = \$550)
- Rental Price includes installation & removal
- If you are in need of a color not listed, please call (831) 883-8600

Per Square Foot:

Advance

\$ 2.75

Floor

\$ 4.00

Color Selection →  Blue Toast Gray Black Burgundy Green Red Bright White

Carpet

Booth size: x = Sq. Ft. @ \$2.75/\$ 4.00 SQ Ft. = \$

Padding

Booth size: x = Sq. Ft. @ \$.80 SQ Ft. = \$

Visqueen

Booth size: x = Sq. Ft. @ \$.35 SQ Ft. = \$

Total: \$



Special Cleaning

- Cost of Vacuuming will be invoiced on the total area of your booth. To avoid any misunderstanding regarding these services, please bring any discrepancies to our attention at the show site. In this way, we will be able to assure your satisfaction with our service.
- Adjustments cannot be made after the close of the show. All rates are subject to change if necessitated by increase in labor or material cost.

Vacuuming and Refuse Removal

We require the following service(s) for our booth number:

Which is x = square feet

Vacuum Carpet
 Every night (*see below). Cost per square foot per night is \$0.30

Vacuuming Carpet
 Before show opens ONLY. Cost per square foot is \$0.35
Orders less then every night but more than once are calculated at this rate.

Calculation of Order:

- When ordering one of the following **daily** services, please calculate for days.

Porter service (Square feet) x (number of days)-----\$

Vacuuming (Square feet) x (number of days)-----\$

Total: \$

CLEANING SERVICES TOTAL: \$

Plant Order Form

Prices are based on a one to three day event, which includes: installation, removal, and matching baskets or pots. An additional charge of twenty (20%) will be added for an event that goes over a three day period.



Areca



Neanthe Bella



Ficus



Dracaena

Flowering Plants----- \$40/ Plant

- Chrysanthemums
- Kalanchoe
- Cyclamen

Quantity-----

Seasonal Flowering Plants-----\$40.00/plant

*Please inquire about prices on seasonal flowering plants
 (Choice of color for all flowering plants is subject to availability)

- Azalea
- Lily
- Poinsettia

Quantity-----

GREEN FOLIAGE PLANTS

2 ½ to 3 feet----- \$ 55 per Plant

- Neanthe Bella
- Palm
- Draecena
- Arbicola
- Boston Fern

Quantity-----

4 ½ to 5 ½ feet-----\$60.00/plant

- Ficus Benjamina
- Ficus Lyrata
- Areca
- Palm
- Draecena

Quantity-----

6 plus feet ----- \$65.00/plant

- Ficus
- Benjamina
- Draecena
- Marginata
- Palms

Quantity-----

Plant Order Total \$



738 Neeson Road, Marina CA 93933
Phone: (831) 883-8600 Fax: (831) 883-8686



Audio-Visual / Computer Equipment Rental Form
phone 831-883-8600

This is for the entire Show rate.
TCC 2013

Order Form

RATES SHOWN ARE FOR THE ENTIRE DURATION OF THE SHOW

Item	Quantity	Show Rate	Total
80" LED LCD (1920x1080) 16:9 Aspect Ratio		\$3,700.00	
70" LED LCD (1920x1080) 16:9 Aspect Ratio		\$1,700.00	
61" Gas Plasma Sony (1368x768) 16:9 Aspect Ratio		\$1,000.00	
52" LCD Flat Panel HP (1920x1080) 16:9 Aspect Ratio		\$875.00	
47" LCD Flat Panel 1920x1080 (1366x768) 16:9 Aspect Ratio		\$625.00	
42" LCD Flat Panel Sony(1920x1080) 16:9 Aspect Ratio		\$475.00	
32" LCD Flat Panel (1920x1080) 16:9 Aspect Ratio		\$500	
24" LCD Flat Panel Samsung (19020x1080) 16:9 Aspect Ratio		\$350	
20" LCD Flat Panel Monitor ViewSonic (1680x1050) 16:9 Aspect Ratio		\$250	
20" LCD Flat Panel Monitor Dell (1600x1200) 4:3 Aspect Ratio		\$250	
17" LCD Flat Panel Monitor Dell (1280x1024) 4:3 Aspect Ratio		\$150	
Dual Pole Stand for Plasma/LCD screen		\$100	
Sound Package - Speaker Set (2), Mixer, Mic		\$400	
Wireless Microphone Package Receiver+Microphone(s)		\$250	
Desktop Core 2 Due 1GB 400G, DVD/CDRW HP		\$300	
Desktop Pentium 2.0		\$200	
Notebook Pentium i3 Core 4gig, 250G, DVD/CDRW, WiFi		\$250	
Tablet PC Notebook Centrino 1.6 GHz, 512MB, 30G, DVD/CDRW, WiFi		\$250	
46" Touch Screen with Laptop 1920x1080 Montor NEC		\$1,500.00	
2x2 Video wall NEC 96" 1920x1080 with Controller		\$4,000.00	
3x3 Video wall NEC 138" 1920x1080 with controller		\$8,500.00	

This is only a partial list of our inventory.

Please call for additional equipment

We can configure any system to fit your needs including additional peripherals

	Subtotal	
	25% Delivery charge on total	Delivery Fee
	Tech Support	included
	TOTAL	

Company Information

EXHIBITING FIRM:	BOOTH:
BILLING ADDRESS	PHONE:
CITY, STATE, ZIP	FAX:
SHOW CONTACT:	ONSITE CELL #:
PAYMENT Amex <input type="checkbox"/> MasterCard <input type="checkbox"/> Visa <input type="checkbox"/>	CREDIT CARD#
	CVV#
	EXP DATE:

Equipment cancelled after shipment or on site are subject to a 100% cancellation fee.

Complete form & fax to: 831 883 8686

Terms and Conditions / Payment Options

<p>1. Smart City is the exclusive provider and installer of all Voice, Data and Network services (wired and wireless) including communications cabling. This includes all cabling to meeting rooms, booths, within booths (under carpet and flooring), fiber optic, twisted pair (Category 3, 5 and 6), coaxial and all other data and telecommunications related cabling.</p> <p>2. The use of the network connection(s) provided by Smart City may be used only by the directors, officers and employees of the Company, its guests, its agents and consultants while performing service for the Company and cannot be resold or distributed to other companies or individuals.</p> <p>3. All devices for which Smart City directly or indirectly provides Internet / Network connectivity must pay a device charge or purchase a Smart City assigned IP address.</p> <p>4. Incentive Price applies when a completed order with payment is received no later than 14 days prior to the first day of show move-in. Base Price applies to (a) all orders received from One (1) to Thirteen (13) days before show move-in has started or (b) orders received on or before the 14 day Incentive Deadline without payment (c) orders placed on site or after show move-in has started will be at Base Price plus an additional 20% X Base Price.</p> <p>5. Internet / Network – 10 Mbps, half-duplex, Ethernet access to our backbone, with shared or dedicated Internet access up to 128 Kbps or greater (depending on service ordered) via an RJ-45 jack, is provided for each connection ordered.</p> <p>6. Shared Internet Services Specific: Routers, Streaming Applications, VoIP, DHCP, NAT or Proxy Servers are not allowed with any of our shared Internet / Network services. This includes, but is not limited to, NetPremium, NetStandard, NetBasic, and NetExpress. Smart City can engineer a custom dedicated network(s) to accommodate such special requests. Please call for quote.</p> <p>7. Rates listed include a single IP address, standard installation to the booth in the most convenient manner and does not include computer equipment, NIC card, TCP / IP software or power to the booth.</p> <p>8. Limited Availability: T-1 / DS-3 and other special circuit orders must be placed 45 days prior to show move-in date due to limited availability and to avoid additional charges.</p> <p>9. Wireless Specific: (a) Smart City is the exclusive provider of voice, wired and wireless data service(s) for the Facility. Wireless Devices not authorized by Smart City are strictly prohibited. Customer(s) that desire to showcase their wireless products must contact Smart City 21 days in advance of show move-in to investigate the potential of Smart City engineering a customized cohesive network to operate without interference to other Customer(s), (applicable charges may apply). (b) The use of any wireless device that interferes with the facility's 2.4 / 5.8 GHz wireless data frequency range is prohibited and subject to disconnection at the Customer expense.</p> <p>10. Unless otherwise directed, Smart City is authorized to cut floor coverings to permit installation of service.</p>	<p>11. Internet Performance Disclaimer: Smart City does not guarantee the performance, routing, or throughput; either expressed or implied, of any data circuit(s) connectivity with regards to the Internet and / or Internet backbone(s) beyond the Facility.</p> <p>12. Only Smart City personnel are authorized to modify system wiring or cabling. Material and equipment furnished by Smart City for this service contract shall remain the property of Smart City.</p> <p>13. CANCELLATION – There is a minimum \$150 or 10% Cancellation fee (whichever is greater). Cancellations must be in writing. Additional cancellation charges will apply for orders that have already incurred processing, labor, material, and / or engineering costs. Some broadband services and special circuits cannot be cancelled once ordered and will incur full charges listed / quoted. Credit will not be given for service(s) installed and not used.</p> <p>14. Service problems must be reported to the Smart City Service Desk. Service claims will not be considered unless filed in writing by Customer prior to close of show.</p> <p>15. Any additional cost incurred by SMART CITY to: 1) assist in trouble diagnosis or problem resolution found not to be the fault of SMART CITY or 2) collect information required to complete the installation that customer fails to provide (i.e. floor plans or special circuit numbers) may be billed to the Customer at the prevailing rate.</p> <p>16. Equipment Management: (a) Customers should pick up hubs, wireless devices, telephone instruments and other rental equipment at the Smart City Service Desk. (b) The Customer will be fully responsible for the protection and safekeeping of rental equipment and will be responsible for returning all rental equipment to the Smart City Service Desk within one (1) hour following close of the show.</p> <p>17. The prices listed on this contract do not include Federal, State, Local or Other Taxes and Tax surcharges. Taxes / Tax surcharges will be included on your final bill. Federal Tax ID is 65-0524748.</p> <p>18. NOTE: THE CUSTOMER IS RESPONSIBLE FOR ALL INTERNATIONAL LONG DISTANCE AND OTHER APPLICABLE CHARGES AGAINST ASSIGNED TELEPHONE NUMBER(S)</p> <p>19. All Single Line, Multi-Line, and Dedicated Line Telephone services include Directory Assistance, Information, "0+", Operator assisted, 1-800, 950, credit card type call usage and unlimited Domestic Long Distance. International Call charges will apply.</p> <p>20. Long Distance (International Calls) and Line Restrictions: (a) Credit Card restriction will only allow Local, "1-800" and Credit Card calling. Intl restriction will block all International calling but allow all other type calls. (b) All lines will be blocked from "976" and "900" dialing unless otherwise requested. Additional deposits may be applicable. (c) Smart City will provide a detailed listing of all toll / billable type calls made from applicable services. Additional LD deposits required for Intl companies.</p> <p>21. A per line move fee starting at \$100 (Telephone), \$200 (Internet) may apply to relocate the line(s) after it is installed.</p> <p>22. Prices are based upon current rates and are subject to change without notice.</p>
--	---

(1) All Customer contracts and agreements are solely between SMART CITY and the prospective Customer; (2) SMART CITY is not the employee, agent or partner of the Facility; (3) The Facility is not a party to, nor shall it have any obligations or liabilities whatsoever to any Customer, under any Customer Contract including without limitation, the obligation to provide any of the services covered by such Customer Contract; (4) No representations or warranties are being made by the Facility with respect to any Customer Contract or any Communications Services; (5) The right of the Customer to receive any Communications Service will be terminated if this Agreement is terminated for any reason provided therein; and the Facility will have no obligation to continue providing such service unless the Facility elects in its sole discretion to continue to provide such services itself or through a third party; (6) The provisions of the Customer Contract are separate and independent from the provisions of the Customer's lease space in the building and shall not affect the Customer's obligations under such lease and without limiting the foregoing, in no event shall any default by SMART CITY under the Customer Contract or any failure with respect to any Communications Services have any effect on any Customer's obligations to the Facility under any lease or any other occupancy agreement between such Customer and the Facility.

<p>23. A valid Credit Card number with signature MUST be on file regardless of payment method. For your convenience we will use this authorization to charge your credit card for any additional amounts incurred.</p> <p>24. Smart City accepts payments in US dollars, Checks drawn on a US bank, Wire Transfers or the following Credit Cards: (Amex, MasterCard, Visa,). Make all checks payable to: Smart City.</p> <p>25. Due to the cost of processing checks, any refunds due in the amount of \$10.00 or less will not be refunded except upon written request.</p>	<p>Mail or Fax Completed Orders with Payment and Floor Plan To</p> <p>SMART CITY 5795 W. BADURA AVENUE, SUITE 110 LAS VEGAS, NEVADA 89118 (888) 446-6911 FAX (702) 943-6001</p>
--	---

Customer Acceptance of All Smart City Terms and Conditions / Attachments:

With execution of this document the Customer hereby authorizes Smart City to provide services as requested herein, is authorized to request such services and acknowledges full and complete understanding of the Terms and Conditions and Attachments contained herein & Website.

Print Authorized Name	Authorized Signature	Date
FOR SMART CITY USE: Payment Rec'd (Amount):	Customer No: 2012 - 070 -	

ORDER ON LINE: <https://www.smartcitynetworks.com/order/center.aspx?center=070>

*** Tipping is not permitted. Any request from personnel for gratuities should be reported to Management immediately. ***

Network Security Declaration

Center: Santa Clara CC (070) - CA Company Name: _____
Show: _____ Booth / Room #: _____
Customer / Ref #: 2012 - 070 -

The Network Security Policy implemented for this Facility requires Customer(s) adherence to several necessary precautions in order for Smart City to maintain a healthy, viable network for all Customers. This declaration of compliance with the security requirements as noted herein is an acknowledgement of Smart City's filtering policies and must be completed, signed by an authorized Customer representative and mailed or faxed to Smart City prior to the requested network service(s) being activated for Customer's usage.

Network Security Policy:

Smart City requires that all devices directly or indirectly accessing Smart City's network(s) have the latest virus scan software, Windows® security updates, system patches, and any other technological precautions necessary to protect the Customer(s) and others from viruses, malicious programs, and other disruptive applications. Any device(s) which adversely impacts Smart City's network(s) may cause service interruptions to Customer(s) which can lead to disconnection of the Customer's equipment from the network(s), with or without prior notice at Smart City's sole discretion. The device(s) in question will remain disconnected until all issues are adequately resolved. All charges will apply and no refunds will be given. Additional charges may apply for trouble diagnosis and / or problem resolution.

Smart City has implemented filtering policies on all Internet routers. These filters block all inbound Internet Control Message Protocol (ICMP) -- Ping, Traceroute, etc. -- destined to any Smart City Network(s). Smart City understands that Ping and Traceroute are valuable troubleshooting tools; therefore Smart City's Policy does allow ICMP (Ping & Traceroute) packets sourced from any Smart City network(s).

Further, to avoid infection by common Internet worms (Nachi, MSBlaster, LoveSAN, etc.), Smart City has implemented similar filters on the following TCP and UDP port numbers: UDP – 137, 138, 402, 1434 and TCP – 135, 139, 402, 445, 4444.

Customers requiring inbound or outbound access to any of the filtered ports, should contact a Smart City customer service representative in advance of the event with details of the specific requirements so that Smart City may consider the potential of a customized alternative.

Each Customer's business is important to Smart City and with advanced and timely notification of a Customer's needs we are confident that we can provide network services that perform as expected for all clients.

***** Please inform all show site personnel about the importance of Smart City's Network Security compliance issues *****

***** Services are activated after Smart City is in receipt of this signed declaration of compliance with our network security requirements *****

Device(s) Operating System: _____ Total # of Devices: _____

Type of Anti-Virus Software Installed: Norton McAfee Other: _____

Virus Scan Last Updated - Date: _____ / _____ / _____ Security Updates Last Performed - Date: _____ / _____ / _____

Are You Renting Computers? Yes No Rental Company Name: _____

Rental Company Contact: _____ Contact Number: _____

With execution of this document the Customer hereby attests that Customer provided equipment, which will be connected to Smart City's network(s) at the above noted Facility and Show / Event has been properly protected, contains anti-virus software, and the latest patches and security updates have been installed. Customer(s) also accepts the responsibility for the performance of Customer's equipment and understands the conditions placed on service delivery by this document as well as the potential that additional charges may be incurred should Customer's equipment be found to adversely impact Smart City's network(s) performance. The Customer acknowledges that this Network Security Declaration is part of the Customer Contract allowing Smart City to provide requested service(s) and is subject to change without notice.

Signature _____ Date _____

Printed Name _____ Title _____

Floor Plan – Communications Cable

Center: Santa Clara CC (070) - CA

Company Name: _____

Show: _____

Booth / Room #: _____

Customer / Ref #: 2012 - 070 -

Voice and Data communications cabling. Smart City is the **exclusive installer** of Voice and Data communications cabling. Smart City provides cabling to booths, within booths (under carpet and flooring) and from booth-to-booth. Fiber Optic, twisted pair (Category 3, 5 and 6), coaxial and all other data and telecommunication cable fall under Smart City's area of expertise.

IMPORTANT!! Prior to installation of service, a complete floor plan is required. Please utilize this grid should you not have your own floor plan to send us. You may use a different floor plan for each service group (Telephone, Internet, etc.) or combine all services on one floor plan. For a floor plan to be considered complete it **must** include all the information listed below (Main Distribution Location "MDL", designated location of items within the booth, surrounding booths, scale-length and width).

Adjacent Booth or Aisle# _____

Adjacent Booth or Aisle# _____

X = Main Distribution Location (**MDL**) – The originating line(s) for service, whether from overhead, a floor pocket or a column, will be delivered to a "**MDL**" before being distributed within your booth. Example: Storage area, back of booth, etc. (unless specified, the default for the "**MDL**" will be the back of the booth or at Smart City's discretion, the most convenient location). All distribution of services to their final destination within the booth will originate from the "**MDL**". A per line move fee will apply to relocate services within your booth after they have been engineered and / or installed.

T = Location of Telephones, Fax lines or other telecommunications equipment "**T**".

I / H / PC / C = Location of primary Internet Service "**I**", Hubs "**H**", Patch Cables "**PC**" and / or Computers "**C**". For Smart City to perform your floor work, you will need to indicate the location of each item you want cabled. Make sure to order your floor work, hubs, and patch cables early and in advance of the show moving in.

Orientation = The Booth or Aisle #'s surrounding your booth. A minimum of one surrounding Booth or Aisle # is required (two or more would be more helpful) for Smart City to accurately install your services.

Size = Booth dimensions (example 10x10) _____ . **Scale** = 1 Box is equal to _____ ft.

