

CONTACT INFORMATION

- Website: www.supermicro.com
- General Information: marketing@supermicro.com
- Technical Support: support@supermicro.com
- Phone: +1 (408) 503-8000, Fax: +1 (408) 503-8008

FOR YOUR SYSTEM TO WORK PROPERLY, PLEASE DOWNLOAD APPROPRIATE

- DRIVERS/IMAGES/USER'S MANUAL FROM THE LINKS BELOW:**
- Manuals: <http://www.supermicro.com/support/manuals>
 - Drivers & Utilities: ftp://ftp.supermicro.com/CDR_Images/CDR-X10-UP/
 - Safety: http://www.supermicro.com/about/policies/safety_information.cfm

PACKAGE CONTENTS

- One (1) Supermicro Motherboard
- Ten (10) SATA Cables
- One (1) I/O Shield
- One (1) Quick Reference Guide

Motherboard Layout and Features

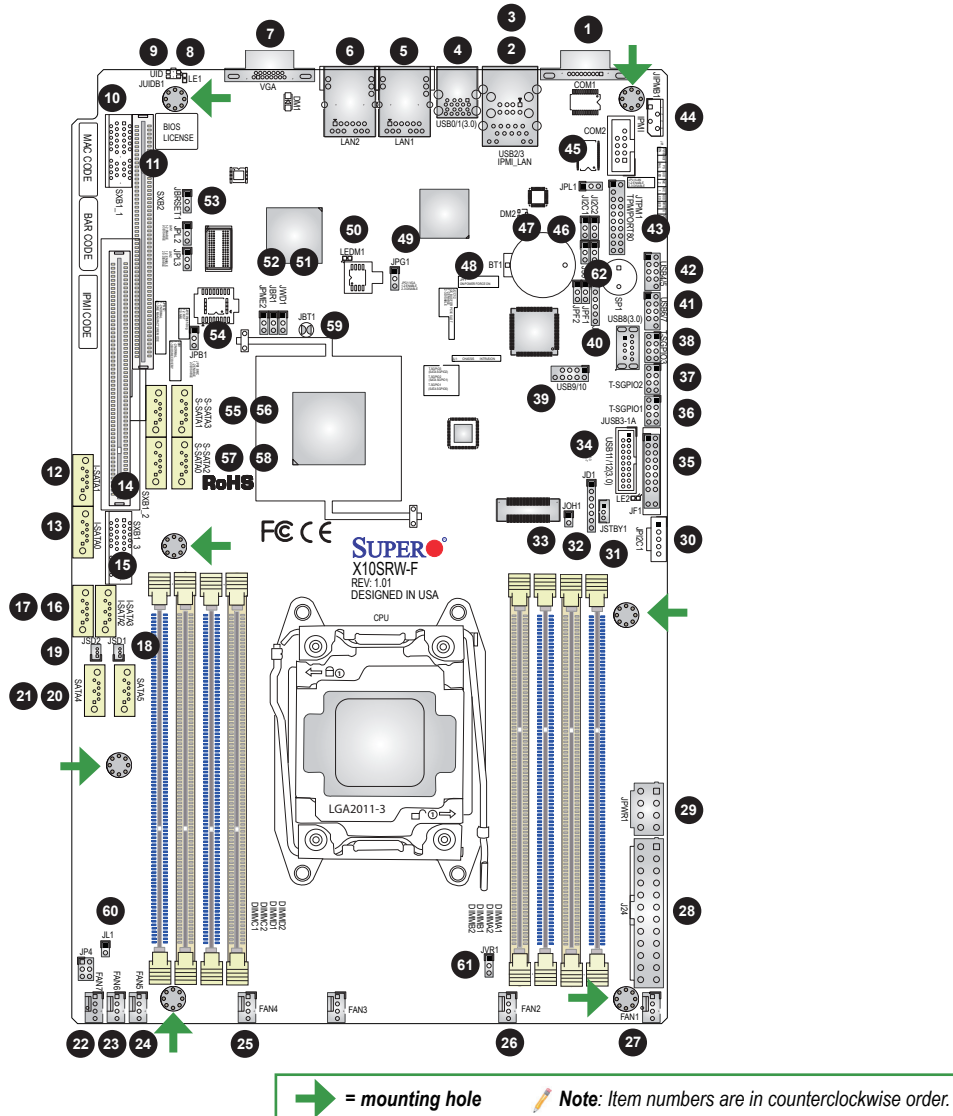

Jumpers and Connectors

Jumpers			
Jumper	Item #	Description	Default
JBR1	52	BIOS Recovery	Pins 1-2 (Normal)
JBRSET1	53	FIQ Request	Pins 1-2 (Normal)
JBT1	59	CMOS Clear	Short: Clear CMOS
JIP1/JIP2	47, 46	SMB to PCI-E Slots	Pins 2-3 (Disabled)
JPB1	54	BMC Enable/Disable	Pins 1-2 (Enabled)
JPG1	49	VGA Enable	Pins 1-2 (Enabled)
JPL1	47	LAN Enable	Pins 1-2 (Enabled)
JWD1	51	Watch Dog Enable	Pins 1-2 (Reset)

Connectors		
Connector	Item #	Description
BT1	48	Onboard Battery
COM1/COM2	1, 45	COM1 (Port)/COM2 (Header)
FAN1-2, FAN4-7	27, 26, 25, 24, 23, 22	System/CPU Fan Headers
J24	28	24-pin Main ATX Power Connector
JD1	32	Speaker/Buzzer (Pins 1-3: Power LED, Pins 4-7: Speaker)
JF1	35	Front Panel Control Header
JIPMB1	44	System Management Bus Header for the IPMI Slot
JL1	60	Chassis Intrusion Header
JOH1	33	Overheat LED/Fan Fail
JIP1C1	30	Power SMB (System Management Bus)
JPWR1	29	8-pin CPU Power Connector
JSD1/JSD2	18, 19	SATA DOM (Device_On_Module) Power Connector
JSTBY1	31	Standby Power Header
JTPM1	44	Trusted Platform Module/Port 80 Connector
JUIDB1	9	UID (Unit Identification) Button
JVR1	61	PWM SMB Programming (for debugging only)
LAN1/LAN2	5, 6	Gigabit (RJ45) Ports (LAN1/2)
IPMI_LAN	2	IPMI_Dedicated LAN
I-SATA 0-3, S-SATA 0-3	13, 12, 17, 16, 57, 55, 58, 56	(Intel PCH) Serial ATA (SATA 3.0) Ports 0-3 S-SATA Ports 0-3 (6Gb/sec)
I-SATA 4/5	21, 20	SATA DOM (Disk_On_Module) Ports 4/5
SP1	62	Internal Speaker/Buzzer
SXB1A, SXB1B, SXB1C	10, 14, 15	SMC-Proprietary WIO_L (Left) Add-On Card slots
SXB2	11	SMC-Proprietary WIO_R (Right) Add-On Card slot
T-SGPIO 1/2/3	36, 37, 38	Serial_Link General Purpose I/O Headers 1/2/3 for SATA Connections
USB 0/1	4	Backpanel USB 3.0 Ports 0/1
USB 2/3	3	Backpanel USB 2.0 Ports 2/3
USB 4/5, 6/7, 9/10	43, 42, 40	Front Panel Accessible USB 2.0 Headers 4/5, 6/7, 9/10
USB 8	41	USB 3.0 Type A Header
USB 11/12 (3.0)	34	Front Panel Accessible USB 3.0 Header 11/12
VGA	7	Backpanel VGA Port

LED Indicators

LED Indicators				
LED	Item #	Description	State/Color	Status
UID-LED	8	UID LED	Blue: On	Unit Identified
LED1	50	BMC Heartbeat LED	Green: Blinking	BMC Normal

Memory Support

The X10SRW-F supports eight ECC DDR4 RDIMM/LRDIMM at 2400 MHz (max.) memory (1 DPC) up to 256GB RDIMM and 512GB LRDIMM. Populating these DIMM modules with a pair of memory modules of the same type and same size will result in interleaved memory, which will improve memory performance.

Populating RDIMM/LRDIMM DDR4 Memory Modules for the E5-2600v3-based Motherboard

Type	Ranks Per DIMM and Data Width	DIMM Capacity (GB)		Speed (MT/s); Voltage (V); Slot Per Channel (SPC) and DIMM Per Channel (DPC)		
		4Gb	8Gb	1 Slot Per Channel	2 Slots Per Channel	3 Slots Per Channel
RDIMM	8Rx4	8GB	16GB	2133	2133	1866
RDIMM	8Rx8	4GB	8GB	2133	2133	1866
RDIMM	8Rx8	8GB	16GB	2133	2133	1866
RDIMM	4Rx4	16GB	32GB	2133	2133	1866
LRDIMM	4Rx4	32GB	64GB	2133	2133	2133
LRDIMM 3DS ¹	8Rx4	64GB	128GB	2133	2133	2133

Populating RDIMM/LRDIMM DDR4 Memory Modules for the E5-2600v4-based Motherboard

Type	Ranks Per DIMM and Data Width	DIMM Capacity (GB)		Speed (MT/s); Voltage (V); Slot Per Channel (SPC) and DIMM Per Channel (DPC)		
		4Gb	8Gb	1 Slot Per Channel	2 Slots Per Channel	3 Slots Per Channel
RDIMM	8Rx4	8GB	16GB	2400	2400	2133
RDIMM	8Rx8	4GB	8GB	2400	2400	2133
RDIMM	8Rx8	8GB	16GB	2400	2400	2133
RDIMM	4Rx4	16GB	32GB	2400	2400	2133
LRDIMM	4Rx4	32GB	64GB	2400	2400	2400
LRDIMM 3DS	8Rx4	64GB	128GB	2400	2400	2400

DIMM Memory Installation

Insert the desired number of DIMMs into the memory slots, starting with DIMMA1 (Channel A, Slot 1).

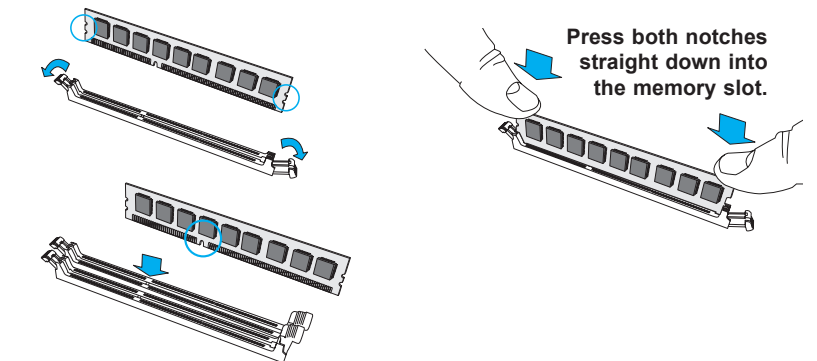

Back Panel I/O Connectors

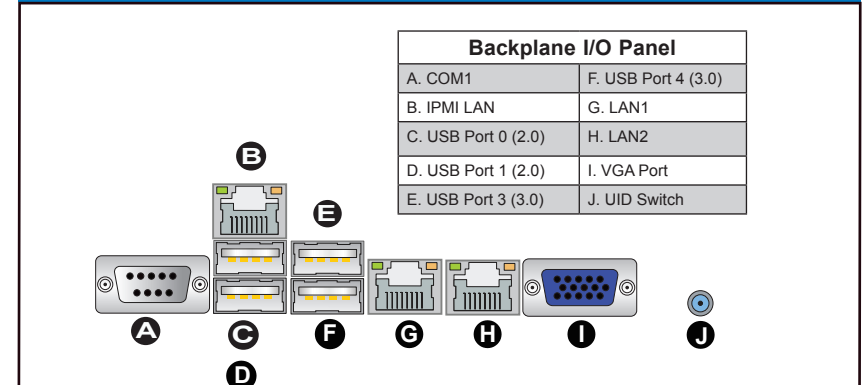

CPU Installation

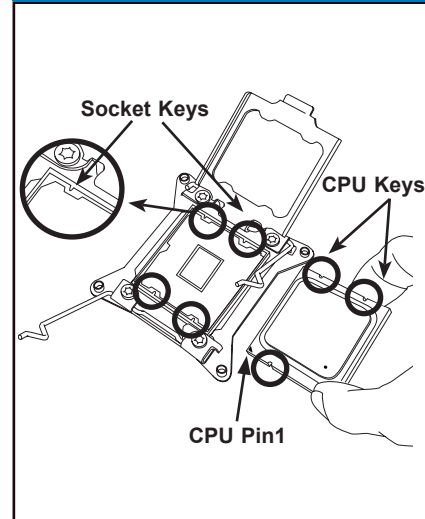

Heatsink Installation

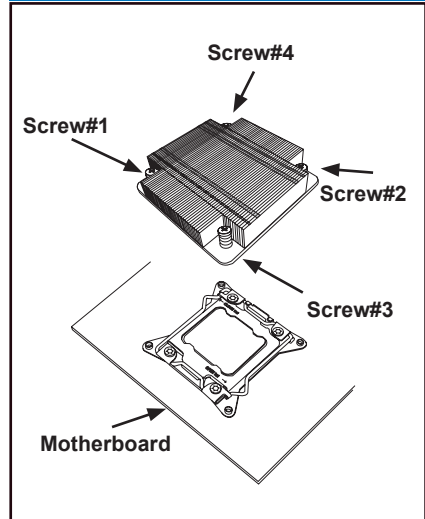

Front Panel Control (JF1)

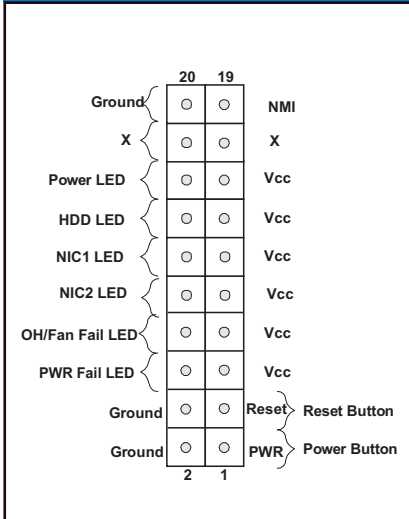

Note: Graphics shown in this quick reference guide are for illustration only. Your components may or may not look exactly the same as drawings shown in this guide.

Note: Refer to Chapter 1 of the User Manual for detailed information on jumpers, connectors, and LED indicators.

Note: Refer to Chapter 2 of the User Manual for detailed information on memory support and CPU/motherboard installation instructions.