



IEI Technology Corp .



**MODEL:
KINO-690S1**

**Mini-ITX Motherboard with AMD® Turion™ 64 x 2,
Mobile Sempron™ CPU with VGA/DVI, USB2.0,
Dual PCIe GbE, SATA II and Audio.**

User Manual

Rev. 1.00 JUNE 2007



Revision

Date	Version	Changes
2007-06-26	1.00	Initial release

Copyright

COPYRIGHT NOTICE

The information in this document is subject to change without prior notice in order to improve reliability, design and function and does not represent a commitment on the part of the manufacturer.

In no event will the manufacturer be liable for direct, indirect, special, incidental, or consequential damages arising out of the use or inability to use the product or documentation, even if advised of the possibility of such damages.

This document contains proprietary information protected by copyright. All rights are reserved. No part of this manual may be reproduced by any mechanical, electronic, or other means in any form without prior written permission of the manufacturer.

TRADEMARKS

All registered trademarks and product names mentioned herein are used for identification purposes only and may be trademarks and/or registered trademarks of their respective owners.

Packing List

**NOTE:**

If any of the components listed in the checklist below are missing, please do not proceed with the installation. Contact the IEI reseller or vendor you purchased the KINO-690S1 from or contact an IEI sales representative directly. To contact an IEI sales representative, please send an email to sales@iei.com.tw.

The items listed below should all be included in the KINO-690S1 package.

- 1 x KINO-690S1 single board computer
- 1 x IDE cable
- 1 x I/O shielding
- 1 x SATA power cables
- 2 x SATA cables
- 1 x Dual RS-232 cable
- 1 x Mini jumper pack
- 1 x Utility CD
- 1 x 1 x QIG (quick installation guide)

Images of the above items are shown in **Chapter 3**.

Table of Contents

1	INTRODUCTION.....	1
1.1	OVERVIEW	2
1.1.1	<i>KINO-690S1 Features.....</i>	2
1.2	KINO-690S1 OVERVIEW.....	2
1.2.1	<i>KINO-690S1 Overview Photo.....</i>	2
1.2.2	<i>KINO-690S1 Peripheral Connectors and Jumpers</i>	4
1.2.3	<i>Technical Specifications.....</i>	5
2	DETAILED SPECIFICATIONS	7
2.1	DIMENSIONS	8
2.1.1	<i>Board Dimensions.....</i>	8
2.1.2	<i>External Interface Panel Dimensions</i>	9
2.2	DATA FLOW	9
2.3	COMPATIBLE PROCESSORS	11
2.3.1	<i>Supported Processors</i>	11
2.3.2	<i>DDR2 Memory Controller</i>	11
2.3.3	<i>Processor Electrical Interfaces.....</i>	12
2.3.4	<i>Processor Power Management</i>	12
2.4	AMD 690G NORTHBRIDGE CHIPSET	12
2.4.1	<i>PCI Express Interface</i>	12
2.4.1.1	<i>PCIe x1 Expansion.....</i>	12
2.4.2	<i>PCIe GbE Ethernet</i>	13
2.4.3	<i>Acceleration Features</i>	14
2.4.4	<i>Display Support</i>	15
2.4.4.1	<i>TV Out</i>	15
2.4.4.2	<i>Multiple Display Features.....</i>	16
2.4.4.3	<i>DVI</i>	16
2.5	AMD SB600 SOUTHBRIDGE CHIPSET.....	16
2.5.1	<i>CPU Interface</i>	16
2.5.2	<i>A-Link Xpress II interface to the Northbridge</i>	16
2.5.3	<i>PCI Host Bus Controller.....</i>	17

2.5.4	USB Controllers	18
2.5.5	SMBus Controller	19
2.5.6	Interrupt Controller	19
2.5.7	DMA Controller	19
2.5.8	LPC host bus controller	19
2.5.9	SATA II AHCI Controller	20
2.5.10	IDE Controller	21
2.5.11	AC Link interface	21
2.5.12	Timers	23
2.5.13	RTC (Real Time Clock)	24
2.5.14	Power Management	24
2.5.15	Hardware Monitor	24
2.6	LPC BUS COMPONENTS	25
2.6.1	LPC Bus Overview	25
2.6.2	BIOS Chipset:	25
2.6.3	TPM Module	26
2.6.4	Super I/O chipset	26
2.6.4.1	Super I/O LPC Interface	27
2.6.4.2	Super I/O 16C550 UARTs	27
2.6.4.3	Super I/O Enhanced Hardware Monitor	27
2.6.4.4	Super I/O Fan Speed Controller	27
2.6.4.5	Super I/O Keyboard and Mouse Controller	27
2.6.4.6	Super I/O Infrared	28
2.6.5	Serial Port Chipset	28
2.7	ENVIRONMENTAL AND POWER SPECIFICATIONS	28
2.7.1	System Monitoring	28
2.7.2	Operating Temperature and Temperature Control	29
2.7.3	Power Consumption	30
3	UNPACKING	31
3.1	ANTI-STATIC PRECAUTIONS	32
3.2	UNPACKING	32
3.2.1	Unpacking Precautions	32
3.3	UNPACKING CHECKLIST	33
3.3.1	Package Contents	33

KINO-690S1 Mini-ITX Motherboard

3.4	OPTIONAL ITEMS.....	35
4	CONNECTOR PINOUTS.....	37
4.1	PERIPHERAL INTERFACE CONNECTORS	38
4.1.1	<i>KINO-690S1 Layout.....</i>	38
4.1.2	<i>Peripheral Interface Connectors</i>	38
4.1.3	<i>External Interface Panel Connectors.....</i>	40
4.2	INTERNAL PERIPHERAL CONNECTORS	40
4.2.1	<i>ATX Power Connector</i>	40
4.2.2	<i>Digital Input/Output (DIO) Connector.....</i>	41
4.2.3	<i>Fan Connector (+12V)</i>	42
4.2.4	<i>Front Panel Connector (14-pin)</i>	43
4.2.5	<i>IDE Connector (40-pin).....</i>	45
4.2.6	<i>Infrared Interface Connector (5-pin).....</i>	46
4.2.7	<i>PCI Slot.....</i>	47
4.2.8	<i>PCI Express x1 Slot.....</i>	52
4.2.9	<i>SATA Drive Connectors</i>	54
4.2.10	<i>Serial Port Connector (COM3)</i>	55
4.2.11	<i>Serial Port Connector (COM4)(RS-232, RS-422 or RS-485)</i>	56
4.2.12	<i>Trusted Platform Module (TPM) Connector.....</i>	57
4.2.13	<i>TV Out Connector</i>	58
4.2.14	<i>USB Connectors (Internal)</i>	59
4.3	EXTERNAL PERIPHERAL INTERFACE CONNECTOR PANEL	60
4.3.1	<i>Audio Connector</i>	60
4.3.2	<i>DVI and VGA Combo Connector.....</i>	61
4.3.3	<i>Keyboard/Mouse Connector</i>	63
4.3.4	<i>LAN Connectors.....</i>	64
4.3.5	<i>Serial Port Connectors (COM1 and COM2).....</i>	66
4.3.6	<i>USB Connector</i>	66
5	INSTALLATION	69
5.1	ANTI-STATIC PRECAUTIONS.....	70
5.2	INSTALLATION CONSIDERATIONS	71
5.2.1	<i>Installation Notices</i>	71
5.2.2	<i>Installation Checklist</i>	72

5.3 UNPACKING.....	73
5.3.1 <i>Unpacking Precautions</i>	73
5.4 CPU, CPU COOLING KIT AND DIMM INSTALLATION	74
5.4.1 <i>AMD Socket S1 CPU Installation</i>	74
5.4.2 <i>Cooling Kit CF-479B-RS Installation</i>	76
5.4.3 <i>SO-DIMM Installation</i>	78
5.5 JUMPER SETTINGS	79
5.5.1 <i>Clear CMOS Jumper</i>	80
5.5.2 <i>COM 4 Function Select Jumper</i>	81
5.6 CHASSIS INSTALLATION	82
5.6.1 <i>Airflow</i>	82
5.6.2 <i>Motherboard Installation</i>	83
5.7 INTERNAL PERIPHERAL DEVICE CONNECTIONS.....	83
5.7.1 <i>Peripheral Device Cables</i>	83
5.7.2 <i>ATA Flat Cable Connection</i>	84
5.7.3 <i>Dual RS-232 Cable Connection</i>	85
5.7.4 <i>SATA Drive Connection</i>	86
5.7.5 <i>USB Cable (Dual Port)</i>	87
5.7.6 <i>USB Cable (Four Port)</i>	88
5.8 EXTERNAL PERIPHERAL INTERFACE CONNECTION	89
5.8.1 <i>Audio Connection</i>	90
5.8.2 <i>DVI Display Device Connection</i>	90
5.8.3 <i>LAN Connection (Single Connector)</i>	91
5.8.4 <i>PS/2 Keyboard and Mouse Connection</i>	92
5.8.5 <i>Serial Device Connection</i>	93
5.8.6 <i>USB Connection (Dual Connector)</i>	94
5.8.7 <i>VGA Monitor Connection</i>	95
6 BIOS SCREENS.....	97
6.1 INTRODUCTION	98
6.1.1 <i>Starting Setup</i>	98
6.1.2 <i>Using Setup</i>	98
6.1.3 <i>Getting Help</i>	99
6.1.4 <i>Unable to Reboot After Configuration Changes</i>	99
6.1.5 <i>BIOS Menu Bar</i>	99

KINO-690S1 Mini-ITX Motherboard

6.2 MAIN	100
6.3 ADVANCED.....	101
6.3.1 CPU Configuration.....	102
6.3.2 IDE Configuration	104
6.3.2.1 IDE Master, IDE Slave	105
6.3.3 Super IO Configuration.....	111
6.3.4 Hardware Health Configuration.....	114
6.3.5 ACPI Configuration	115
6.3.6 Trusted Computing	117
6.3.7 Remote Access Configuration	118
6.3.8 USB Configuration.....	122
6.3.8.1 USB Mass Storage Device Configuration.....	124
6.4 PCI/PNP	127
6.5 BOOT	133
6.5.1 Boot Settings Configuration.....	134
6.5.2 Boot Device Priority	136
6.5.3 Hard Disk Drives	137
6.5.4 CD/DVD Drives.....	139
6.6 SECURITY.....	140
6.7 CHIPSET	142
6.7.1 NorthBridge Chipset Configuration	143
6.7.2 ECC Configuration	145
6.7.3 Internal Graphics Configuration.....	147
6.7.4 SouthBridge Configuration.....	150
6.8 POWER.....	152
6.9 EXIT.....	155
7 SOFTWARE DRIVERS	159
7.1 AVAILABLE SOFTWARE DRIVERS	160
7.2 DRIVER CD AUTO-RUN.....	160
7.3 AMD 690G CHIPSET DRIVER INSTALLATION.....	162
7.4 BROADCOM LAN DRIVER (FOR GBE LAN) INSTALLATION	167
7.5 REALTEK AC`97 AUDIO DRIVER (ALC655) INSTALLATION	172
7.5.1 BIOS Setup.....	172
7.5.2 Driver Installation	172

7.6 WEBPAM RAID UTILITY DRIVER INSTALLATION	177
A BIOS OPTIONS	183
B DIO INTERFACE.....	189
B.1 DIO INTERFACE INTRODUCTION	190
B.2 DIO CONNECTOR PINOUTS	190
B.3 ASSEMBLY LANGUAGE SAMPLES.....	191
<i>B.3.1 Enable the DIO Input Function.....</i>	<i>191</i>
<i>B.3.2 Enable the DIO Output Function</i>	<i>191</i>
C WATCHDOG TIMER	193
D ADDRESS MAPPING.....	197
D.1 ADDRESS MAP	198
D.2 1ST MB MEMORY ADDRESS MAP	198
D.3 IRQ MAPPING TABLE.....	199
D.4 DMA CHANNEL ASSIGNMENTS.....	199
E HAZARDOUS MATERIALS DISCLOSURE	201
E.1 HAZARDOUS MATERIAL DISCLOSURE TABLE FOR IPB PRODUCTS CERTIFIED AS ROHS COMPLIANT UNDER 2002/95/EC WITHOUT MERCURY.....	202
F RAID SETUP	205
F.1 INTRODUCTION	206
<i>F.1.1 Precautions</i>	<i>206</i>
F.2 FEATURES AND BENEFITS.....	207
F.3 ACCESSING THE AMD SB600 RAID UTILITY	207
INDEX.....	211

List of Figures

Figure 1-1: KINO-690S1 Overview [Front View].....	3
Figure 1-2: External Peripheral Interface Connectors	3
Figure 2-1: KINO-690S1 Dimensions (mm)	8
Figure 2-2: External Interface Panel Dimensions (mm).....	9
Figure 2-3: Data Flow Block Diagram.....	10
Figure 2-4: SO-DIMM Sockets	11
Figure 2-5: PCIe x1 Expansion Slot	13
Figure 2-6: Broadcom PCI GbE Controllers.....	14
Figure 2-7: PCI Expansion Slot	17
Figure 2-8: USB Connectors.....	18
Figure 2-9: SATA Connectors	20
Figure 2-10: IDE Connector	21
Figure 2-11: Audio Codec and Audio Jacks	22
Figure 2-12: LPC BUS Components	25
Figure 4-1: Connector and Jumper Locations.....	38
Figure 4-2: ATX Power Connector Pinout Locations.....	41
Figure 4-3: DIO Connector Connector Locations.....	42
Figure 4-4: +12V Fan Connector Location	43
Figure 4-5: Front Panel Connector Pinout Locations (14-pin).....	44
Figure 4-6: IDE Device Connector Locations	45
Figure 4-7: Infrared Connector Pinout Locations	47
Figure 4-8: PCI Slot Location	49
Figure 4-9: PCI Express x1 Slot Locations	53
Figure 4-10: SATA Drive Connector Locations	54
Figure 4-11: Serial Connector Pinout Locations	55
Figure 4-12: RS-232/422/485 Serial Port Connector Location.....	56
Figure 4-13: TPM Connector Pinout Locations	57
Figure 4-14: TV Connector Pinout Locations	58

Figure 4-15: USB Connector Pinout Locations	59
Figure 4-16: KINO-690S1 External Peripheral Interface Connector	60
Figure 4-17: Audio Connector	61
Figure 4-18: DVI Connector Pinouts	62
Figure 4-19: VGA Connector	63
Figure 4-20: PS/2 Pinouts	64
Figure 4-21: RJ-45 Ethernet Connector	65
Figure 4-22: Pinout Locations	66
Figure 5-1: Make sure the CPU socket retention screw is unlocked	75
Figure 5-2: IEI CF-479B-RS Cooling Kit	76
Figure 5-3: Cooling Kit Support Bracket	77
Figure 5-4: Connect the cooling fan cable	77
Figure 5-5: SO-DIMM Installation	78
Figure 5-6: Clear CMOS Jumper	81
Figure 5-7: COM4 Function Select Jumper Location	82
Figure 5-8: IDE Cable Connection	84
Figure 5-9: Dual RS-232 Cable Installation	85
Figure 5-10: SATA Drive Cable Connection	86
Figure 5-11: SATA Power Drive Connection	87
Figure 5-12: Dual USB Cable Connection	88
Figure 5-13: Four Port USB Cable Connection	89
Figure 5-14: Audio Connectors	90
Figure 5-15: DVI Connector	91
Figure 5-16: LAN Connection	92
Figure 5-17: PS/2 Keyboard/Mouse Connector	93
Figure 5-18: Serial Device Connector	94
Figure 5-19: USB Connector	95
Figure 5-20: VGA Connector	96
Figure 7-1: Introduction Screen	161
Figure 7-2: Available Drivers	161
Figure 7-3: Chipset Driver Installation Program	162
Figure 7-4: Chipset Driver Installation Welcome Screen	163

KINO-690S1 Mini-ITX Motherboard

Figure 7-5: Chipset Driver Installation License Agreement	163
Figure 7-6: Select Destination Folder	164
Figure 7-7: Chipset Driver Installing Screen.....	164
Figure 7-8: Welcome Screen	165
Figure 7-9: Chipset Driver Readme File Information	165
Figure 7-10: Chipset Driver Installation Complete	166
Figure 7-11: Setup Complete.....	167
Figure 7-12: Windows Control Panel.....	168
Figure 7-13: System Icon	169
Figure 7-14: Device Manager Tab	169
Figure 7-15: Device Manager List	170
Figure 7-16: Search for Suitable Driver	171
Figure 7-17: Locate Driver Files	171
Figure 7-18: Location Browsing Window	172
Figure 7-19: Select the Audio CODEC.....	173
Figure 7-20: Locate the Setup Program Icon.....	174
Figure 7-21: Preparing Setup Screen	174
Figure 7-22: InstallShield Wizard Welcome Screen	175
Figure 7-23: Audio Driver Software Configuration.....	175
Figure 7-24: Audio Driver Digital Signal.....	176
Figure 7-25: Audio Driver Installation	176
Figure 7-26: Restart the Computer	177
Figure 7-27: Chipset Driver Installation Program.....	178
Figure 7-28: Chipset Drivers.....	178
Figure 7-29: RAID Utility Icon	179
Figure 7-30: SATA RAID Setup Program Icon	179
Figure 7-31: Welcome Screen	180
Figure 7-32: WebPAM License Agreement	180
Figure 7-33: Select WebPAM Installation Destination	181
Figure 7-34: WebPAM Ready to Install.....	181
Figure 7-35: WebPAM Installation	182
Figure 7-36: WebPAM Installation Complete.....	182

List of Tables

Table 1-1: Technical Specifications.....	6
Table 2-1: Power Consumption.....	30
Table 3-1: Package List Contents	34
Table 3-2: Package List Contents	35
Table 4-1: Peripheral Interface Connectors	39
Table 4-2: Rear Panel Connectors	40
Table 4-3: ATX Power Connector Pinouts	41
Table 4-4: DIO Connector Connector Pinouts	42
Table 4-5: +12V Fan Connector Pinouts.....	43
Table 4-6: Front Panel Connector Pinouts (14-pin)	44
Table 4-7: IDE Connector Pinouts	46
Table 4-8: Infrared Connector Pinouts	47
Table 4-9: PCI Slot	51
Table 4-10: PCI Express x1 Slot Pinouts.....	54
Table 4-11: SATA Drive Connector Pinouts.....	55
Table 4-12: Serial Connector Pinouts.....	56
Table 4-13: RS-232/RS-485 Serial Port Connector Pinouts.....	57
Table 4-14: TPM Connector Pinouts.....	58
Table 4-15: TV Port Connector Pinouts.....	59
Table 4-16: USB Port Connector Pinouts.....	60
Table 4-17: DVI Connector Pinouts	62
Table 4-18: VGA Connector Pinouts.....	63
Table 4-19: PS/2 Connector Pinouts.....	64
Table 4-20: LAN Pinouts	65
Table 4-21: RJ-45 Ethernet Connector LEDs	65
Table 4-22: RS-232 Serial Port Pinouts	66
Table 4-23: USB Port Pinouts.....	67
Table 5-1: Jumpers.....	79

KINO-690S1 Mini-ITX Motherboard

Table 5-2: Clear CMOS Jumper Settings.....	80
Table 5-3: COM4 Function Select Jumper Settings	81
Table 5-4: IEI Provided Cables	83
Table 6-1: BIOS Navigation Keys	99

BIOS Menus

Menu 1: Main	100
Menu 2: Advanced	102
Menu 3: CPU Configuration	103
Menu 4: IDE Configuration	104
Menu 5: IDE Master and IDE Slave Configuration.....	106
Menu 6: Super IO Configuration	111
Menu 7: Hardware Health Configuration.....	114
Menu 8: ACPI Configuration.....	116
Menu 9: Trusted Computing	117
Menu 10: Remote Access Configuration [Advanced].....	119
Menu 11: USB Configuration.....	123
Menu 12: USB Mass Storage Device Configuration.....	125
Menu 13: PCI/PnP Configuration	128
Menu 14: Boot.....	134
Menu 15: Boot Settings Configuration	135
Menu 16: Boot Device Priority Settings	137
Menu 17: Hard Disk Drives	138
Menu 18: CD/DVD Drives	140
Menu 19: Security.....	141
Menu 20: Chipset.....	143
Menu 21:NorthBridge Chipset Configuration	144
BIOS Menu 22: ECC Configuration Chipset Configuration.....	145
BIOS Menu 23: Internal Graphics Configuration.....	148
Menu 24:SouthBridge Chipset Configuration	151
Menu 25:Power	153
Menu 26:Exit.....	156

Glossary

AC '97	Audio Codec 97	I/O	Input/Output
ACPI	Advanced Configuration and Power Interface	ICH4	I/O Controller Hub 4
APM	Advanced Power Management	L1 Cache	Level 1 Cache
ARMD	ATAPI Removable Media Device	L2 Cache	Level 2 Cache
ASKIR	Shift Keyed Infrared	LCD	Liquid Crystal Display
ATA	Advanced Technology Attachments	LPT	Parallel Port Connector
BIOS	Basic Input/Output System	LVDS	Low Voltage Differential Signaling
CFII	Compact Flash Type 2	MAC	Media Access Controller
CMOS	Complementary Metal Oxide Semiconductor	OS	Operating System
CPU	Central Processing Unit	PCI	Peripheral Connect Interface
Codec	Compressor/Decompressor	PIO	Programmed Input Output
COM	Serial Port	PnP	Plug and Play
DAC	Digital to Analog Converter	POST	Power On Self Test
DDR	Double Data Rate	RAM	Random Access Memory
DIMM	Dual Inline Memory Module	SATA	Serial ATA
DIO	Digital Input/Output	S.M.A.R.T	Self Monitoring Analysis and Reporting Technology
DMA	Direct Memory Access	SPD	Serial Presence Detect
EIDE	Enhanced IDE	S/PDI	Sony/Philips Digital Interface
EIST	Enhanced Intel SpeedStep Technology	SDRAM	Synchronous Dynamic Random Access Memory
FDD	Floppy Disk Drive	SIR	Serial Infrared
FDC	Floppy Disk Connector	UART	Universal Asynchronous Receiver-transmitter
FFIO	Flexible File Input/Output	USB	Universal Serial Bus
FIFO	First In/First Out	VGA	Video Graphics Adapter
FSB	Front Side Bus		
IrDA	Infrared Data Association		
HDD	Hard Disk Drive		
IDE	Integrated Data Electronics		



THIS PAGE IS INTENTIONALLY LEFT BLANK

Chapter

1

Introduction

1.1 Overview

The KINO-690S1 Mini-ITX form factor CPU card is an AMD Socket S1 processor platform. Up to 4GB of DDR2 SO-DIMM SDRAM and up to four SATA II hard disk drives (HDD) are supported. SATA drives can be installed in a RAID configuration. High-performance PCI Express (PCIe) Gigabit Ethernet (GbE) connectivity is integrated into the system. Eight USB 2.0 channels along with a PCI expansion slot enable system flexibility and expansion. Multi-display interfaces and dual display functions ensure display versatility. Support for a (optional) trusted platform module (TPM) provides additional system security during system boot-up.™

1.1.1 KINO-690S1 Features

Some of the KINO-690S1 features are listed below.

- Supports the following AMD Socket S1 processors:
 - AMD Turion™ 64 X2 dual-core mobile
 - Mobile AMD Sempron™
- Supports two 200-pin 400MHz, 533MHz or 667MHz DDR2 SO-DIMMs with a maximum capacity of 2GB.
- Four SATA II drives with transfer rates of 3.0Gb/s supported
- Two Ultra ATA 133, Ultra ATA 100, Ultra ATA 66 or Ultra ATA 33 IDE HDDs supported
- Eight USB 2.0 devices supported
- Dual PCIe GbE Ethernet connectors
- Mini-ITX form factor
- RoHS compliant
- Supports ATX power supplies

1.2 KINO-690S1 Overview

1.2.1 KINO-690S1 Overview Photo

The KINO-690S1 has a wide variety of peripheral interface connectors. **Figure 1-1** is a labeled photo of the peripheral interface connectors on the KINO-690S1.

KINO-690S1 Mini-ITX Motherboard

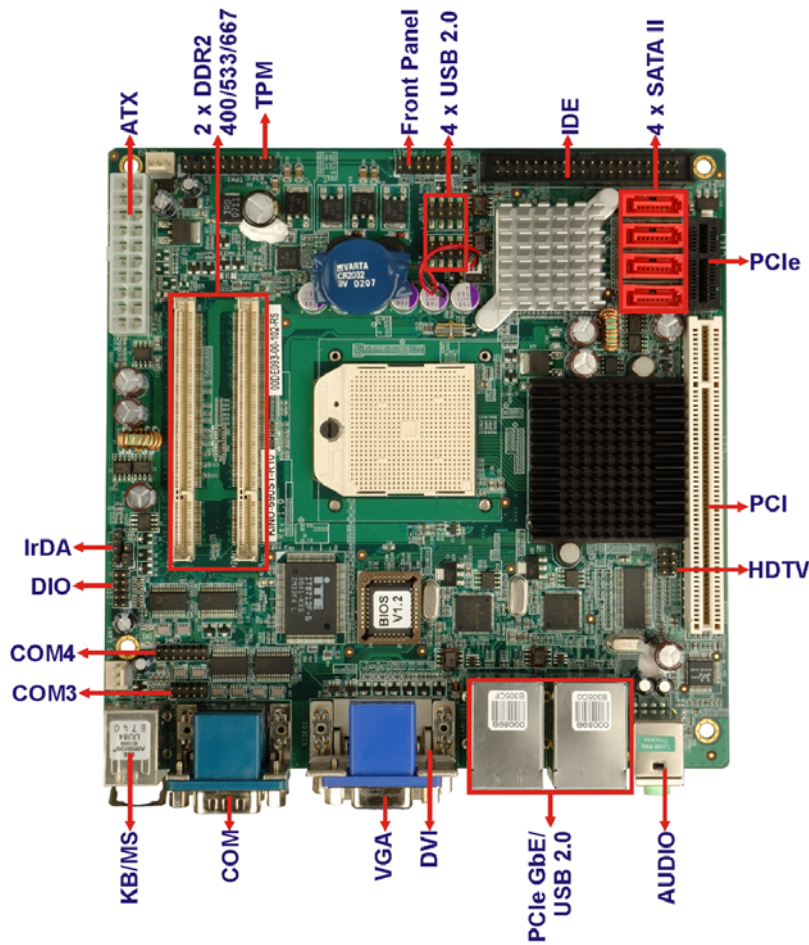

Figure 1-1: KINO-690S1 Overview [Front View]

Figure 1-2 shows the external peripheral interface connectors (EPIC).

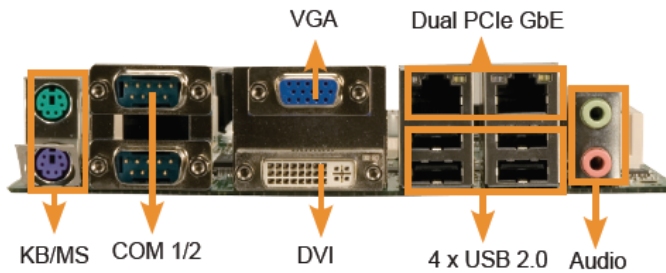

Figure 1-2: External Peripheral Interface Connectors

1.2.2 KINO-690S1 Peripheral Connectors and Jumpers

The KINO-690S1 has the following connectors on-board:

- 1 x ATX power connector
- 1 x Digital input/output connector
- 2 x Fan connectors
- 1 x Front panel connector
- 1 x IDE disk drive connector
- 1 x Infrared interface connector
- 1 x PCI slot
- 1 x PCIe slot
- 4 x Serial ATA II (SATA II) drive connectors
- 1 x RS-232 Serial port connector
- 1 x RS-232/422/485 Serial port connector
- 1 x TPM connector
- 1 x TV Out connector
- 2 x USB 2.0 connectors (support four USB 2.0 devices)

The KINO-690S1 has the following external peripheral interface connectors on the board rear panel.

- 2 x Audio Jacks
- 2 x Ethernet connectors
- 1 x DVI-D connector
- 2 x PS/2 connectors
- 2 x Serial port connectors
- 4 x USB connectors
- 1 x VGA connector

The KINO-690S1 has the following on-board jumpers:

- Clear CMOS
- RS-232/422/485 COM4 setup

KINO-690S1 Mini-ITX Motherboard

1.2.3 Technical Specifications

KINO-690S1 technical specifications are listed in **Table 1-1**. See **Chapter 2** for details.

Specification	KINO-690S1
Form Factor	Mini-ITX
System CPU	AMD Socket S1 Turion™ 64 X2 AMD Socket S1 Sempron™
HyperTransport™ Technology	Up to 1600 MHz HyperTransport™ interfaces supported
System Chipset	Northbridge: AMD 690G Southbridge: AMD SB600
Memory	Two 200-pin DDR2 SO-DIMM sockets support two 400MHz, 533MHz, or 667MHz un-buffered DDR2 SO-DIMMs with a maximum capacity of 2GB each
Super I/O	ITE8712F
Display Interface	VGA Integrated in the AMD® 690G with Radeon Xpress 1250 Graphic Core
	Supports HDTV resolutions up to 1080i by component interface
	DVI by AMD® 690G with dual display support
BIOS	AMI Flash BIOS
Audio	RealTek ALC655 with AC'97 codec
LAN	Dual Broadcom PCIe GbE chipsets
COM	Three RS-232 serial ports
	One RS-232/422/485 serial port

USB2.0	Eight USB 2.0 devices supported
IDE	One 40-pin IDE connector connects to two Ultra ATA33/66/100/133 devices
SATA	Four 3.0Gb/s SATA II drives supported
Keyboard/mouse	Two PS/2 connectors
Expansion	One PCI slot One PCIe x1 slot
Digital I/O	One 8-bit digital input/output connector; 4-bit input/4-bit output
Watchdog Timer	Software programmable 1-255 sec. by super I/O
Infrared	One IrDA connector by Super I/O
Power Supply	AT/ATX power
Power Consumption	5.0V@3.65A AND 12V@1.12A (AMD® Mobile Sempron 3500+ CPU with a 667MHz 512MB DDR2 SO-DIMM)
Temperature	0°C – 60°C (32°F - 140°F)
Humidity (operating)	5%~95% non-condensing
Dimensions (LxW)	170mm x 170mm
Weight (GW/NW)	900g/342g

Table 1-1: Technical Specifications

Chapter

2

Detailed Specifications

2.1 Dimensions

2.1.1 Board Dimensions

The dimensions of the board are listed below:

- **Length:** 170mm
- **Width:** 170mm

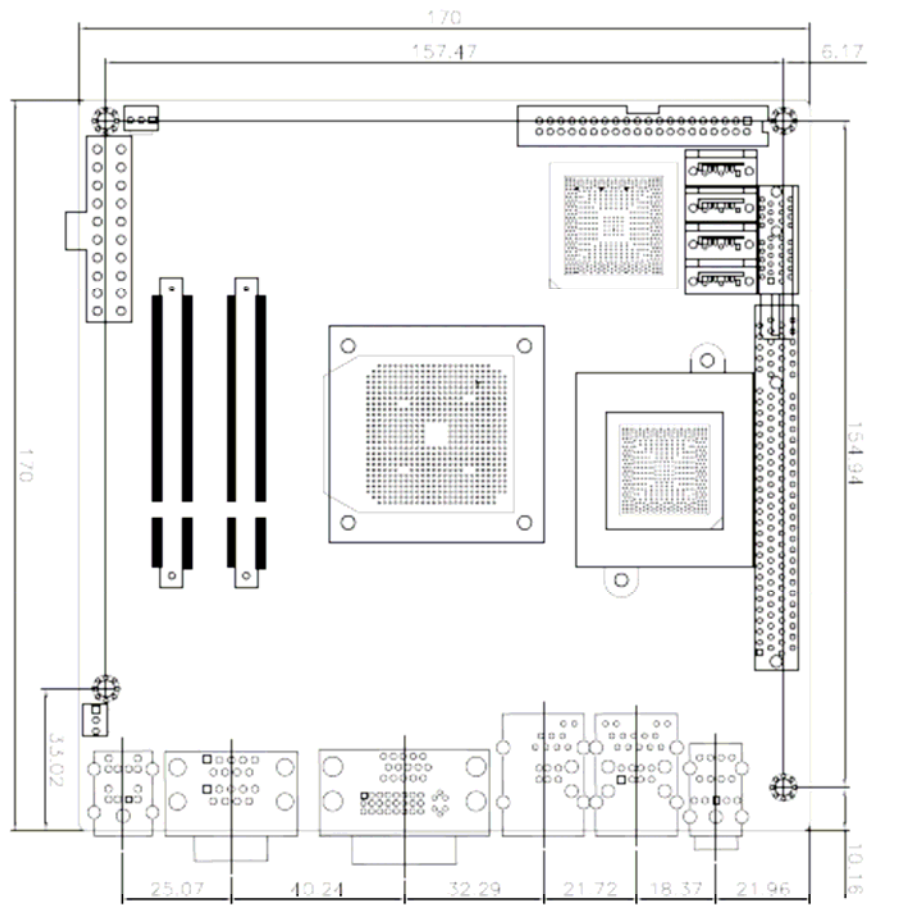

Figure 2-1: KINO-690S1 Dimensions (mm)

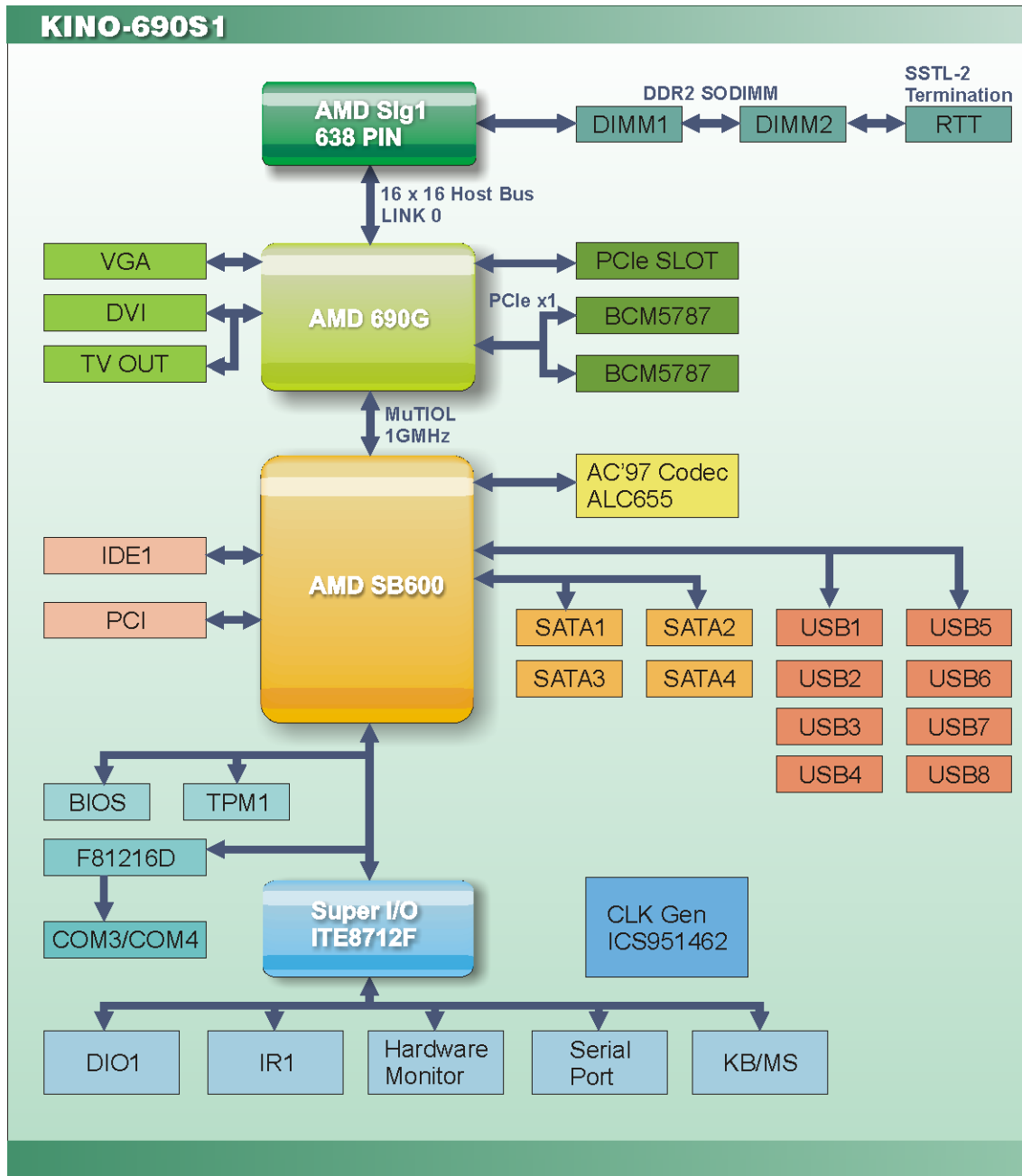

Figure 2-3: Data Flow Block Diagram

KINO-690S1 Mini-ITX Motherboard

2.3 Compatible Processors

2.3.1 Supported Processors

The KINO-690S1 supports the following AMD Socket S1 processors

- AMD Turion™ 64 X2 dual-core mobile processor
- Mobile AMD Sempron™ processor

2.3.2 DDR2 Memory Controller

All processors supported by the KINO-690S1 CPU card have their own DDR2 memory controller. The DDR2 controller has the following features:

- Low-latency, high-bandwidth
- 667MHz 128-bit DDR2 SDRAM controller
- Supports up to two un-buffered DDR2 SO-DIMM
- Each SO-DIMM has a maximum capacity of 2GB

The DDR2 controller on the processor is interfaced to two SO-DIMM sockets on the KINO-690S1.

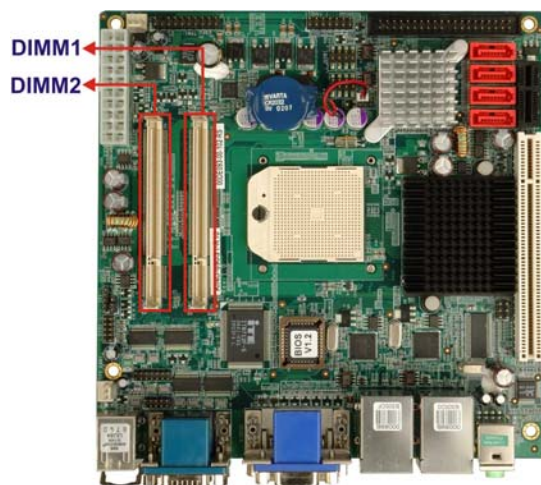

Figure 2-4: SO-DIMM Sockets

2.3.3 Processor Electrical Interfaces

The supported processors have the following electrical interfaces:

- HyperTransport™ technology: LVDS-like differential, unidirectional
- DDR2 SDRAM: SSTL_1.8 per JEDEC specification
- Clock, reset, and test signals also use DDR2
- SDRAM-like electrical specifications.

2.3.4 Processor Power Management

The supported processors have the following power management features:

- Multiple low-power states including Deeper Sleep (C1E with AltVID)
- System Management Mode (SMM)
- ACPI compliant, including support for processor performance states
- AMD PowerNow!™ technology is designed to dynamically switch between multiple low-power states based on application performance requirements.

2.4 AMD 690G Northbridge Chipset

2.4.1 PCI Express Interface

The AMD 690G PCIe bus is compliant with the PCI Express 1.1a. Three of the four AMD 690G lanes are implemented on the KINO-690S1 motherboard. One of these lanes is interfaced to a PCIe x1 expansion slot. Two other PCIe x1 lanes are interfaced to two Broadcom PCIe GbE controllers.

2.4.1.1 PCIe x1 Expansion

One PCIe x1 lane from the AMD 690G is interfaced to a PCIe x1 expansion slot. See **Figure 2-5**. A standard PCIe x1 can be inserted into the slot to provide additional functionality to the system.

KINO-690S1 Mini-ITX Motherboard



Figure 2-5: PCIe x1 Expansion Slot

2.4.2 PCIe GbE Ethernet

Two PCIe x1 lanes from the AMD 690G Northbridge are interfaced to two Broadcom BCM5787M PCIe GbE controllers shown in **Figure 2-6** below.

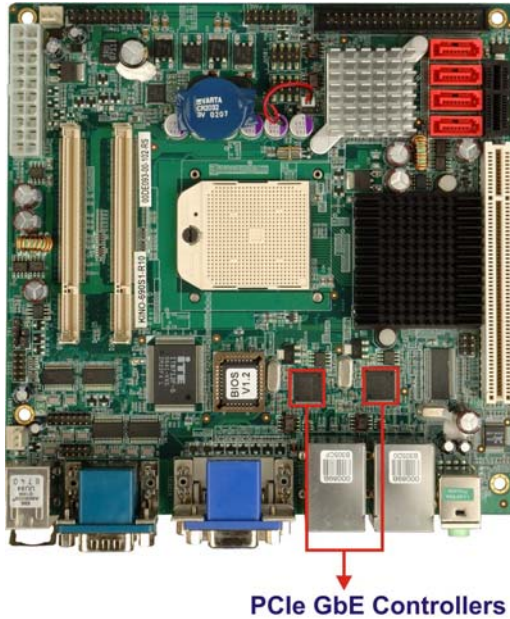

Figure 2-6: Broadcom PCI GbE Controllers

The Broadcom BCM5787M is a 10/100/1000BASE-T Ethernet LAN controller. The BCM5787M combines a triple-speed IEEE 802.3 compliant Media Access Controller (MAC) with a triple-speed Ethernet transceiver, a PCIe bus interface, and an on-chip buffer memory. Some of the BCM5787 controller features are listed below:

- Integrated 10/100/1000BASE-T transceiver
- Automatic MDI crossover function
- PCIe v1.0a
- 10/100/1000BASE-T full/half-duplex MAC
- Wake on LAN support meeting the ACPI requirements
- Statistics for SNMP MIB II, Ethernet-like MIB, and Ethernet MIB (802.3z, clause 30)
- Serial EEPROM or serial flash support

2.4.3 Acceleration Features

The AMD 690G has the following 2D acceleration features:

- Highly optimized 128-bit engine, capable of processing multiple pixels per clock

KINO-690S1 Mini-ITX Motherboard

- Supports a maximum resolution of 2048x1536 @ 32bpp
- Game acceleration including support for Microsoft's DirectDraw

The AMD 690G also has the following 3D acceleration features:

- Full DirectX 9.0 support
- 3D Texture support, including projective 3D textures
- Anti-aliasing using multi-sampling algorithm with support for 2,4, and 6 samples
- New generation rendering engine provides top 3D performance
- Support for OpenGL format for Indirect Vertices in Vertex Walker

Motion video acceleration features on the AMD 690G include:

- Enhanced MPEG-2 hardware decode acceleration
- MPEG-4 decode support
- Hardware acceleration for WMV9 playback
- Supports top quality DVD and time-shifted SDTV/HDTV television playback with low CPU usage

2.4.4 Display Support

The AMD 690G supports dual independent displays. The following display interface connectors are on the KINO-690S1:

- TV Out
- DVI-D
- VGA

2.4.4.1 TV Out

TV Out features include:

- Integrated TV encoder from Xilleon products with integrated Avivo™
- Supports Macrovision 7.1 copy protection standard (required by DVD players)
- Supports the formats of component, composite and S-video outputs

2.4.4.2 Multiple Display Features

The Multiple display features include

- Dual independent displays including one digital outputs *
- Resolution, refresh rates, and display data can be completely independent for the two display paths
- Supports both interlaced and non-interlaced displays

2.4.4.3 DVI

DVI support features include:

- Supports a TMDS interface, enabling DVI <1650 Mbps/channel with 165 MHz pixel clock rate per link
- HDCP 1.1 support on data stream with on-chip key storage

2.5 AMD SB600 Southbridge Chipset

2.5.1 CPU Interface

The AMD SB600 Southbridge chipset supports the following AMD Socket S1 processors:

- AMD Turion™ 64 X2 dual-core mobile processor
- Mobile AMD Sempron™ processor

2.5.2 A-Link Xpress II interface to the Northbridge

The AMD SB600 Southbridge is connected to the AMD 690G Northbridge chipset through an A-Link Xpress II interface. Some of the A-Link Xpress II interface features are listed below:

- 1/2/4-lane A-Link Xpress II interface
- Dynamic detection of lane configuration
- High data transfer bandwidth

KINO-690S1 Mini-ITX Motherboard

2.5.3 PCI Host Bus Controller

The PCI interface on the AMD SB600 Southbridge is compliant with the PCI Revision 2.3 implementation. Some of the features of the PCI interface are listed below.

- PCI rev. 2.3 specifications
- PCI bus at 33 MHz
- Up to 6 master devices
- 40-bit addressing
- Interrupt steering for plug-n-play devices
- Concurrent PCI operations
- Hiding of PCI devices by BIOS/hardware
- Spread spectrum

The PCI bus is interfaced to a PCI expansion slot (see **Figure 2-7**).



Figure 2-7: PCI Expansion Slot

2.5.4 USB Controllers

Eight of the ten high-speed, full-speed or low-speed USB devices on the AMD SB600 are implemented on the KINO-690S1. High-speed USB 2.0, with data transfers of up to 480MB/s, is enabled with the AMD SB600 integrated Enhanced Host Controller Interface (EHCI) compliant host controller. USB full-speed and low-speed signaling are enabled with the integrated Universal Host Controller Interface (UHCI) controllers.

The USB controller supports the following:

- USB 1.1 (“Low Speed”, “Full Speed”) and 2.0 (“High Speed”)
- ACPI S1~S5
- Legacy keyboard/mouse
- USB debug port
- Port disable with individual control

Four of the eight USB ports are interfaced to two 8-pin headers on the KINO-690S1. Four more USB ports are interfaced to four external USB connectors. See **Figure 2-8**.

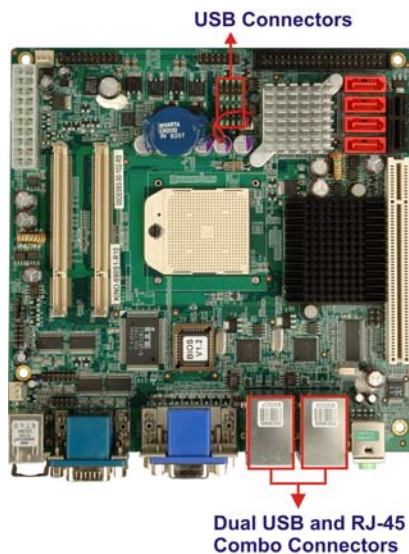

Figure 2-8: USB Connectors

KINO-690S1 Mini-ITX Motherboard

2.5.5 SMBus Controller

The AMD SB600 southbridge chipset SMBus Controller is SMBus Rev. 2.0 compliant and supports SMBALERT # signal / GPIO.

2.5.6 Interrupt Controller

The AMD SB600 southbridge interrupt controller supports the following:

- IOAPIC/X-IO APIC mode for 24 channels of interrupts
- 8259 legacy mode for 15 interrupts
- Programmable level/edge triggering on each channels
- Serial interrupt on quiet and continuous modes

2.5.7 DMA Controller

The AMD SB600 southbridge has two cascaded 8237 DMA controllers that support the following:

- PC/PCI/DMA
- LPC DMA
- Type F DMA

2.5.8 LPC host bus controller

The AMD SB600 Southbridge LPC interface complies with the LPC 1.1 and LPC 1.2 specifications. The LPC bus from the Southbridge is connected to the following components:

- BIOS chipset
- Super I/O chipset
- TPM connector

Some of the features of the LPC bus are listed below.

- Supports LPC based super I/O and flash devices
- Supports two master/DMA devices
- Supports TPM version 1.1/1.2 devices for enhanced security

- Supports SPI devices

2.5.9 SATA II AHCI Controller

The integrated SATA controllers on the AMD SB600 Southbridge supports four SATA II drives on the KINO-690S1 with independent DMA operations. The SATA controller supports the following:

- Four SATA ports, complying with SATA 2.0 specifications
- SATA II 3.0GHz PHY, with backward compatibility with 1.5GHz
- RAID stripping (RAID 0) across all 4 ports
- RAID mirroring (RAID 1) across all 4 ports
- RAID 10 (4 ports needed)
- Both AHCI mode and IDE mode
- Advanced power management with AHCI mode

The four SATA connectors are shown in Figure 2-9.

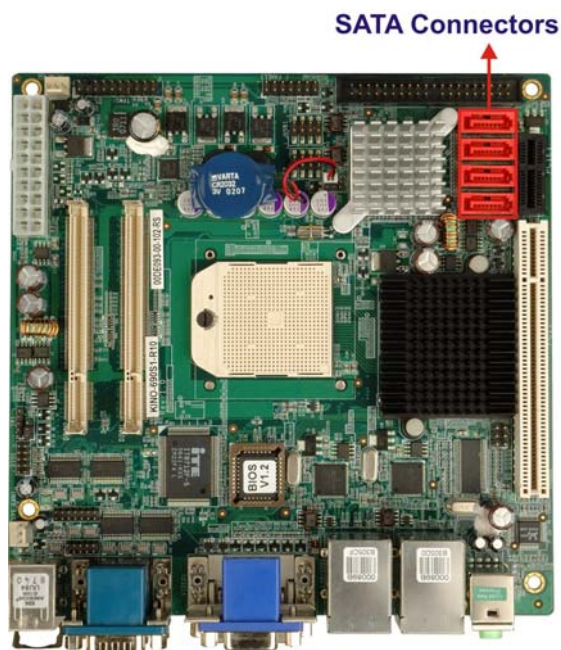

Figure 2-9: SATA Connectors

KINO-690S1 Mini-ITX Motherboard

2.5.10 IDE Controller

The AMD SB600 Southbridge IDE controller is interfaced to a single IDE connector. The IDE controller has the following specifications.

- Single PATA channel support
- Support PIO, multi-word DMA, and Ultra DMA 33/66/100/133 modes
- 32x32 byte buffers on each channel for buffering
- Swap bay support by tri-state IDE signals
- Supports Messages Signaled Interrupt (MSI)
- Integrated IDE series resistor

The IDE connector is shown in Figure 2-10.



Figure 2-10: IDE Connector

2.5.11 AC Link interface

The AMD SB600 southbridge AC Link interface has the following features:

- Supports for both audio and modem Codecs
- Compliant with AC-97 codec Rev. 2.3

- 6/8 channel support on audio codec
- Multiple functions for audio and modem Codec operations
- Bus master logic
- Supports up to 3 codecs simultaneously
- Supports SDIF output
- AC Link

The AC Link Interface is connected to a 16-bit, full-duplex AC'97 Rev. 2.3 compatible six-channel RealTek ALC655 audio CODEC. The ALC655 is then connected to three externally accessible audio jacks. See **Figure 2-11**.

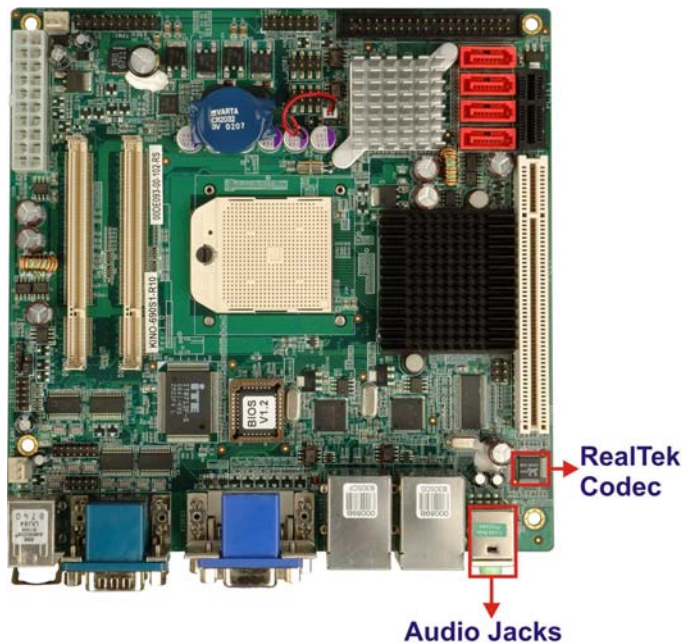

Figure 2-11: Audio Codec and Audio Jacks

Some of the features of the ALC655 are listed below:

- Complies with PC99/2001 systems audio performance requirements
- Complies with Microsoft WHQL/WLP 2.0 audio requirements
- 16-bit Stereo full-duplex CODEC with 48KHz sampling rate
- Compliant with AC'97 Rev 2.3 specifications
 - Front-Out, Surround-Out, MIC-In and LINE-In Jack Sensing
 - 14.318MHz -> 24.576MHz PLL to eliminate crystal

KINO-690S1 Mini-ITX Motherboard

- 12.288MHz BITCLK input
- Integrated PCBEEP generator to save buzzer
- Interrupt capability
- Three analog line-level stereo inputs with 5-bit volume control, LINE_IN, CD, AUX
- High-quality differential CD input
- Two analog line-level mono inputs: PCBEEP, PHONE-IN
- Dedicated Front-MIC input for front panel applications (software selectable)
- Boost preamplifier for MIC input
- LINE input shared with surround output; MIC input shared with Center and LFE output
- Built-in 50mW/20ohm amplifier for both Front-out and Surround-Out
- External Amplifier Power Down (EAPD) capability
- Power management and enhanced power saving features
- Supports Power-Off CD function
- Adjustable VREFOUT control
- Supports 48KHz S/PDIF output, complying with AC'97 Rev 2.3 specifications
- Supports 32K/44.1K/48KHz S/PDIF input
- Power support: Digital: 3.3V; Analog: 3.3V/5V
- EAX™ 1.0 & 2.0 compatible
- Direct Sound 3D™ compatible
- A3D™ compatible
- I3DL2 compatible
- HRTF 3D positional audio
- 10-band software equalizer
- Voice cancellation and key shifting in Karaoke mode
- AVRack® Media Player
- Configuration Panel for improved user convenience

2.5.12 Timers

The AMD SB600 south bridge has the following timers

- 8254-compatible timer
- Microsoft High Precision Event Timer (HPET)
- ACPI power management timer

2.5.13 RTC (Real Time Clock)

256 bytes of battery backed RAM is provided by the real time clock (RTC) integrated into the AMD SB600. The RTC keeps track of the time and stores system data even when the system is turned off. Some of the features of the RTC are listed below:

- 256-byte battery backed CMOS RAM
- Hardware supported century rollover
- RTC battery monitoring feature

2.5.14 Power Management

ACPI specification 3.0 compliant power management schemes on the AMD SB600 include:

- Supports C2, C3, C4
- Supports C1e and C3 pop-up (AMD platform only)
- Supports S0, S1, S2, S3, S4, and S4
- Supports SpeedStep™
- Full support for On-Now™
- Supports CPU SMM, generating SMI# signal upon power management events
- GPIO supports on external wake up events
- Supports CLKRUN# on PCI power management
- Provides clock generator and CPU STPCLK# control
- Hardware monitoring support
- Support for ASF

2.5.15 Hardware Monitor

The AMD SB600 has the following hardware monitoring features:

- Supports 3 Independent Fan Control outputs
- Supports 4 thermal diode temperature sensing functions
- Supports 1 AMDSI function

KINO-690S1 Mini-ITX Motherboard

2.6 LPC Bus Components

2.6.1 LPC Bus Overview

The LPC bus is connected to components listed below:

- BIOS chipset
- Super I/O chipset
- Serial Port Chipset
- TPM module connector

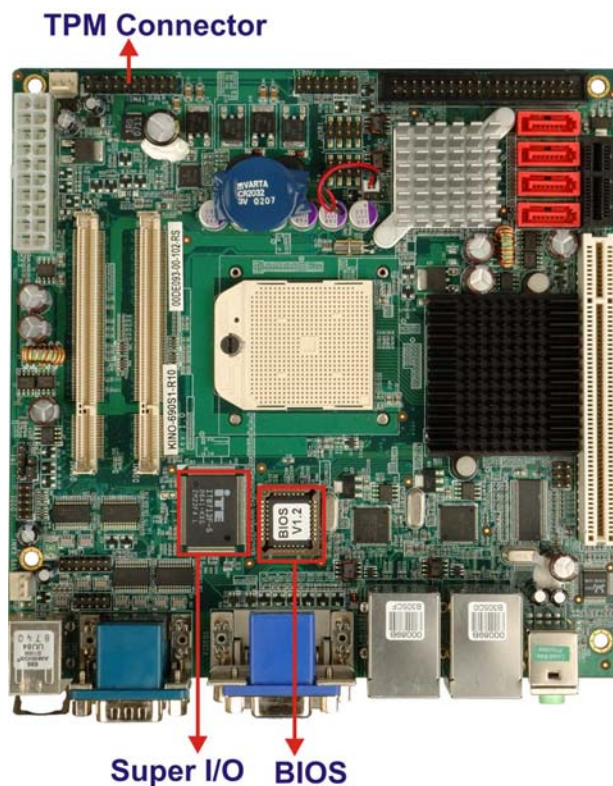

Figure 2-12: LPC BUS Components

2.6.2 BIOS Chipset:

The BIOS chipset has a licensed copy of AMI BIOS installed on the chipset. Some of the BIOS features are listed below:

- AMI Flash BIOS

- SMIBIOS (DMI) compliant
- Console redirection function support
- PXE (Pre-boot Execution Environment) support
- USB booting support

2.6.3 TPM Module

A TPM connector on the KINO-690S1 is interfaced to the AMD SB600 southbridge through the LPC bus. The AMD SB600 Southbridge supports TPM version 1.1 and TPM version 1.2 devices for enhanced security. Three TPM are available from IEI. The three IEI TPM are listed below:

- Infineon TPM module
- Sinosun TPM module
- Winbond TPM module

For more information about these modules please refer to **Chapter 3** or contact the KINO-690S1 reseller or vendor. Alternatively, please contact IEI at sales@iei.com.tw.

2.6.4 Super I/O chipset

The iTE IT8712F Super I/O chipset is connected to the AMD SB600 southbridge through the LPC bus. The iTE IT8712F is an LPC interface-based Super I/O device that comes with Environment Controller integration. Some of the features of the iTE IT8712F chipset are listed below:

- PC98/99/2001, ACPI and LANDesk Compliant
- Enhanced Hardware Monitor
- Fan Speed Controller
- Single +5V Power Supply
- Two 16C550 UARTs for serial port control
- One IEEE 1284 Parallel Port
- Keyboard Controller
- Watchdog Timer
- Serial IRQ Support
- Vbat & Vcch Support

KINO-690S1 Mini-ITX Motherboard

- Single +5V Power Supply

Some of the Super I/O features are described in more detail below:

2.6.4.1 Super I/O LPC Interface

The LPC interface on the Super I/O complies with the AMD[®] Low Pin Count Specification Rev. 1.0. The LPC interface supports both LDRQ# and SERIRQ protocols as well as PCI PME# interfaces.

2.6.4.2 Super I/O 16C550 UARTs

The onboard Super I/O has two integrated 16C550 UARTs that can support the following:

- Two standard serial ports
- IrDa 1.0 and ASKIR protocols

2.6.4.3 Super I/O Enhanced Hardware Monitor

The Super I/O Enhanced Hardware Monitor monitors three thermal inputs, VBAT internally, and eight voltage monitor inputs. These hardware parameters are reported in the BIOS and can be read from the BIOS Hardware Health Configuration menu.

2.6.4.4 Super I/O Fan Speed Controller

The Super I/O fan speed controller enables the system to monitor the speed of the fan. One of the pins on the fan connector is reserved for fan speed detection and interfaced to the fan speed controller on the Super I/O. The fan speed is then reported in the BIOS.

2.6.4.5 Super I/O Keyboard and Mouse Controller

The Super I/O keyboard and mouse controller can execute the 8042 instruction set. Some of the keyboard and mouse controller features are listed below:

- The 8042 instruction is compatible with a PS/2 keyboard and PS/2 mouse
- Gate A20 and Keyboard reset output
- Supports multiple keyboard power on events
- Supports mouse double-click and/or mouse move power on events

2.6.4.6 Super I/O Infrared

The Super I/O has dedicated infrared (IrDA) pins that are interfaced to an IrDA connector. The IrDA connector is compatible with the following standards:

- ASKIR
- SIR

2.6.5 Serial Port Chipset

The KINO-690S1 has a Fintek F81216DG chipset onboard enables the addition of two additional UART serial ports (COM3 and COM4). UART includes 16-byte send/receive FIFO. The Fintek serial port chipset is interfaced to the southbridge chipset through the LPC bus. Some of the features of the Fintek chipset are listed below:

- Supports LPC interface
- Provides UART (16550 asynchronous) ports
 - 1 x Pure UART
 - 1 x UART+IR
- One Watch dog timer with WDTOUT# signal
- One Frequency input 24/48MHz
- Powered by 3Vcc

2.7 Environmental and Power Specifications

2.7.1 System Monitoring

Three thermal inputs on the KINO-690S1 Super I/O Enhanced Hardware Monitor monitor the following temperatures:

- CPU temperature
- System temperature

Five voltage inputs on the KINO-690S1 Super I/O Enhanced Hardware Monitor monitors the following voltages:

- CPU Core

KINO-690S1 Mini-ITX Motherboard

- +1.20V
- +3.3V
- +5.0V
- 5VSB
- VBAT

The KINO-690S1 Super I/O Enhanced Hardware Monitor also monitors the following fan speeds:

- CPU Fan speed
- System Fan speed

The values for the above environmental parameters are all recorded in the BIOS Hardware Health Configuration menu.

2.7.2 Operating Temperature and Temperature Control

The maximum and minimum operating temperatures for the KINO-690S1 are listed below.

- Minimum Operating Temperature: 0°C (32°F)
- Maximum Operating Temperature: 60°C (140°F)

A cooling fan and heat sink must be installed on the CPU. Thermal paste must be smeared on the lower side of the heat sink before it is mounted on the CPU. Heat sinks are also mounted on the northbridge and southbridge chipsets to ensure the operating temperature of these chips remain low.

2.7.3 Power Consumption

Table 2-1 shows the power consumption parameters for the KINO-690S1 running with a AMD Mobile Sempron 3500+ CPU and a 512MB 667MHz DDR2 SO-DIMM.

Voltage	Current
+5.0V	3.65A
+12V	1.12A

Table 2-1: Power Consumption

Chapter

3

Unpacking

3.1 Anti-static Precautions



WARNING:

Failure to take ESD precautions during the installation of the KINO-690S1 may result in permanent damage to the KINO-690S1 and severe injury to the user.

Electrostatic discharge (ESD) can cause serious damage to electronic components, including the KINO-690S1. Dry climates are especially susceptible to ESD. It is therefore critical that whenever the KINO-690S1, or any other electrical component is handled, the following anti-static precautions are strictly adhered to.

- **Wear an anti-static wristband:** - Wearing a simple anti-static wristband can help to prevent ESD from damaging the board.
- **Self-grounding:**- Before handling the board touch any grounded conducting material. During the time the board is handled, frequently touch any conducting materials that are connected to the ground.
- **Use an anti-static pad:** When configuring the KINO-690S1, place it on an anti-static pad. This reduces the possibility of ESD damaging the KINO-690S1.
- **Only handle the edges of the PCB:-** When handling the PCB, hold the PCB by the edges.

3.2 Unpacking

3.2.1 Unpacking Precautions

When the KINO-690S1 is unpacked, please do the following:

- Follow the anti-static precautions outlined in **Section 3.1**.
- Make sure the packing box is facing upwards so the KINO-690S1 does not fall out of the box.
- Make sure all the components shown in **Section 3.3** are present.

KINO-690S1 Mini-ITX Motherboard

3.3 Unpacking Checklist





NOTE:

If some of the components listed in the checklist below are missing, please do not proceed with the installation. Contact the IEI reseller or vendor you purchased the KINO-690S1 from or contact an IEI sales representative directly. To contact an IEI sales representative, please send an email to sales@iei.com.tw.

3.3.1 Package Contents

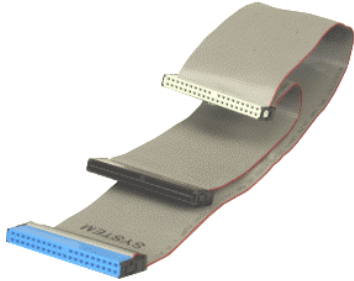
The KINO-690S1 is shipped with the following components:

Quantity	Item and Part Number	Image
1	KINO-690S1	
1	ATA 66/100 flat cable (P/N: 32200-000052-RS)	
1	I/O Shielding (P/N:45014-0008C0-00-RS)	



1	Dual RS-232 cable (P/N: 19800-000051-RS)	
2	SATA cables (P/N: 32000-062800-RS)	
1	SATA power cables (P/N: 32100-088600-RS)	
1	Mini jumper Pack	
1	Quick Installation Guide	
1	Utility CD	

Table 3-1: Package List Contents

KINO-690S1 Mini-ITX Motherboard

3.4 Optional Items





<p>CPU cooler (P/N: CF-479B-RS)</p>	
<p>HDTV Output Cable (P/N: 32000-083701-RS)</p>	
<p>Dual RS-232 cable (P/N: 32200-000077-RS)</p>	
<p>Dual USB cable (w bracket) (P/N:CB-USB02-RS)</p>	
<p>4-port USB cable (P/N: CB-USB14-RS)</p>	

Table 3-2: Package List Contents



THIS PAGE IS INTENTIONALLY LEFT BLANK

Chapter

4

Connector Pinouts

4.1 Peripheral Interface Connectors

Section 4.1.2 shows peripheral interface connector locations. Section 4.1.2 lists all the peripheral interface connectors seen in Section 4.1.2.

4.1.1 KINO-690S1 Layout

Figure 4-1 shows the on-board peripheral connectors, rear panel peripheral connectors and on-board jumpers.

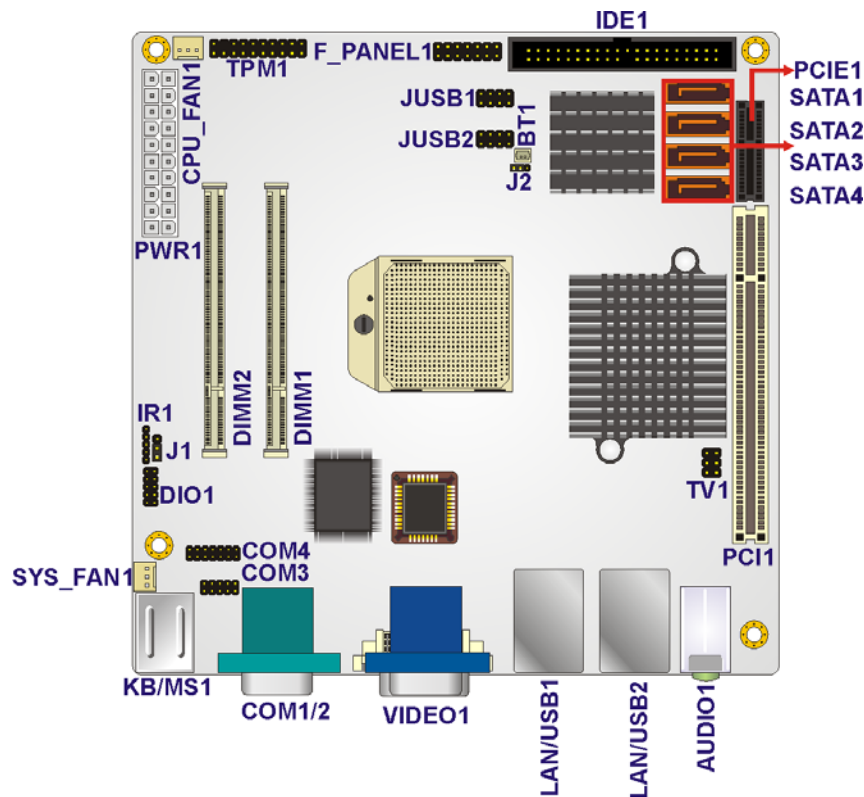

Figure 4-1: Connector and Jumper Locations

4.1.2 Peripheral Interface Connectors

Table 4-1 shows a list of the peripheral interface connectors on the KINO-690S1. Detailed descriptions of these connectors can be found below.

KINO-690S1 Mini-ITX Motherboard

Connector	Type	Label
Audio connector	10-pin header	FPAUDIO1
ATX power connector	20-pin ATX	PWR1
Cooling fan connector, CPU	3-pin header	CPU_FAN1
Cooling fan connector, System	3-pin header	CPU_SYS1
Digital input/output connector	10-pin header	DIO1
Front panel connector	14-pin header	F_PANEL1
IDE Interface connector	40-pin box header	IDE1
Infrared (IrDA) connector	5-pin header	IR1
PCI expansion slot	124-pin PCI slot	PCI1
PCIe x1 expansion slot	36-pin PCIe slot	PCIE1
Serial ATA drive connector	7-pin SATA	SATA1
Serial ATA drive connector	7-pin SATA	SATA2
Serial ATA drive connector	7-pin SATA	SATA3
Serial ATA drive connector	7-pin SATA	SATA4
Serial port connector (COM3)	10-pin box header	COM3
Serial port connector (COM4)	14-pin box header	COM4
TPM connector	20-pin header	TPM1
TV Out connector	16-pin header	TV
USB connectors	8-pin header	JUSB1
USB connectors	8-pin header	JUSB2

Table 4-1: Peripheral Interface Connectors

4.1.3 External Interface Panel Connectors

Table 4-2 lists the rear panel connectors on the KINO-690S1. Detailed descriptions of these connectors can be found in **Section 4.3** on **page 60**.

Connector	Type	Label
DVI and VGA combo connector	DVI and DB-15	VIDEO1
Ethernet and dual USB combo connector	RJ-45 and two USB	LAN/USB1
Ethernet and dual USB combo connector	RJ-45 and two USB	LAN/USB2
Mouse or keyboard connector	PS/2	KB/MS1
Serial port connector (COM1)	DB-9 (male)	COM1
Serial port connector (COM2)	DB-9 (male)	COM2

Table 4-2: Rear Panel Connectors

4.2 Internal Peripheral Connectors

Internal peripheral connectors are found on the motherboard and are only accessible when the motherboard is outside of the chassis. This section has complete descriptions of all the internal, peripheral connectors on the KINO-690S1.

4.2.1 ATX Power Connector

CN Label:	J2
CN Type:	20-pin ATX (2x10)
CN Location:	See Figure 4-2
CN Pinouts:	See Table 4-3

The ATX connector is connected to an external ATX power supply. Power is provided to the system, from the power supply through this connector.

KINO-690S1 Mini-ITX Motherboard

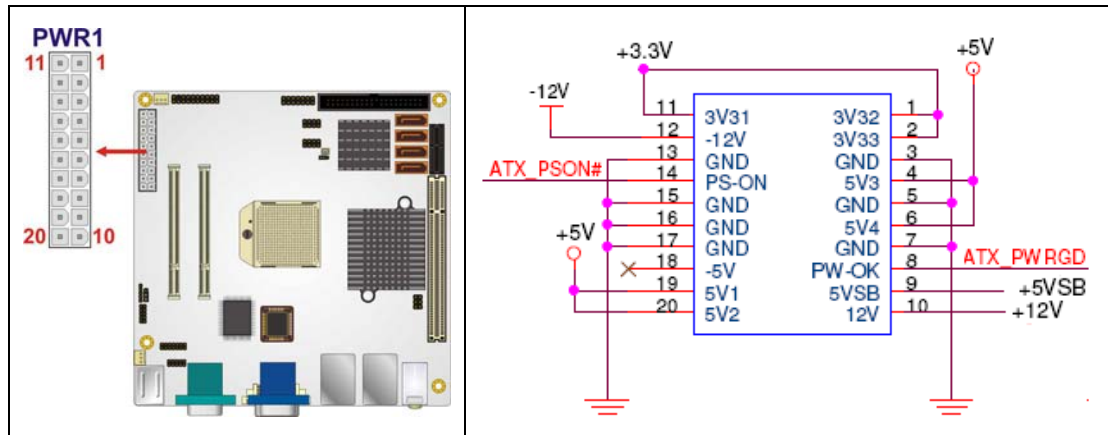

Figure 4-2: ATX Power Connector Pinout Locations

PIN NO.	DESCRIPTION	PIN NO.	DESCRIPTION
1	+ 3.3V	11	+ 3.3V
2	+ 3.3V	12	-12V
3	GND	13	GND
4	+5V	14	PS-ON
5	GND	15	GND
6	+5V	16	GND
7	GND	17	GND
8	PW-OK	18	N/C
9	+VCC5SB	19	+5V
10	+12V	20	+5V

Table 4-3: ATX Power Connector Pinouts

4.2.2 Digital Input/Output (DIO) Connector

- CN Label:** DIO1
- CN Type:** 10-pin header (2x5)
- CN Location:** See Figure 4-3
- CN Pinouts:** See Table 4-4

The digital input/output connector is managed through a Super I/O chip. The DIO connector pins are user programmable.

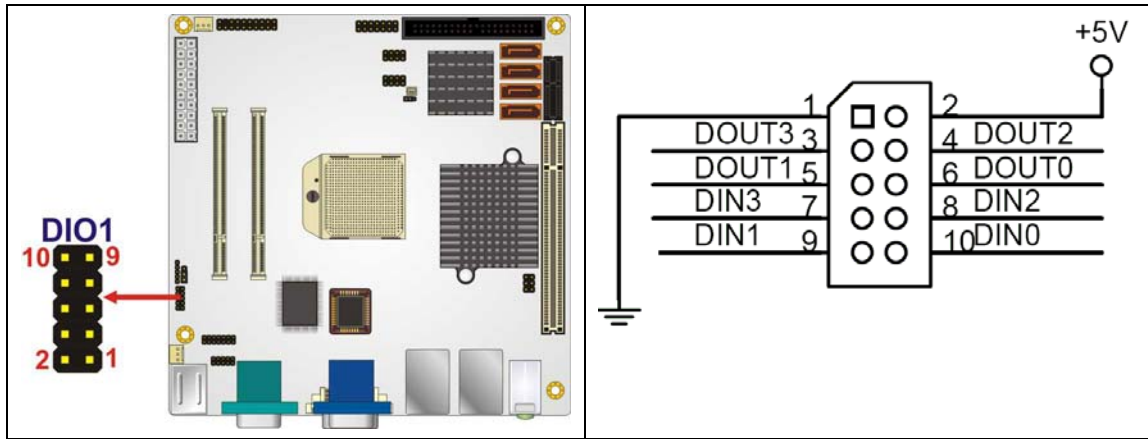

Figure 4-3: DIO Connector Connector Locations

PIN NO.	DESCRIPTION	PIN NO.	DESCRIPTION
1	GND	2	VCC
3	Output 3	4	Output 2
5	Output 1	6	Output 0
7	Input 3	8	Input 2
9	Input 1	10	Input 0

Table 4-4: DIO Connector Connector Pinouts

4.2.3 Fan Connector (+12V)

CN Label: CPU_FAN1, SYS_FAN1

CN Type: 3-pin header

CN Location: See Figure 4-4

CN Pinouts: See Table 4-5

The cooling fan connector provides a 12V, 500mA current to a system cooling fan. The connector has a "rotation" pin to get rotation signals from fans and notify the system so the

KINO-690S1 Mini-ITX Motherboard

system BIOS can recognize the fan speed. Please note that only specified fans can issue the rotation signals.

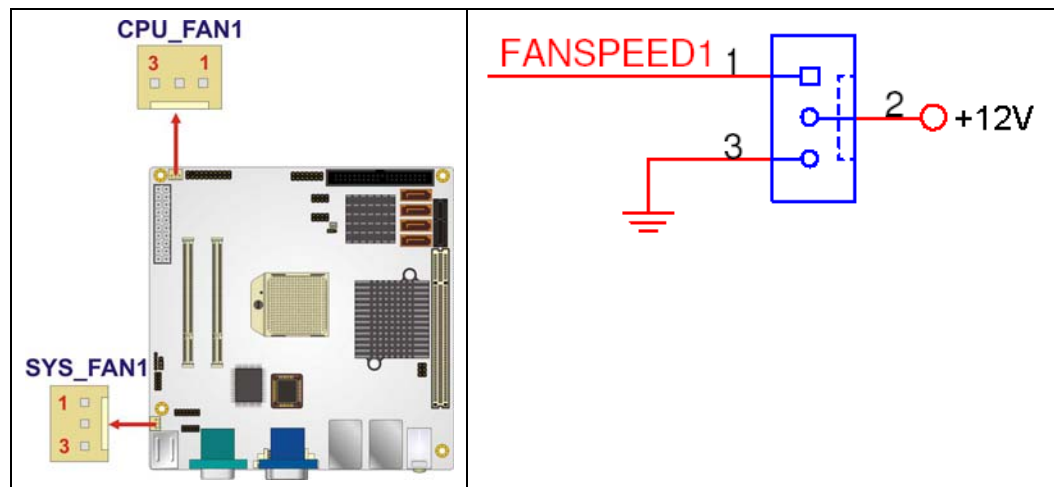

Figure 4-4: +12V Fan Connector Location

PIN NO.	DESCRIPTION
1	GND Rotation Signal
2	+12V
3	GND

Table 4-5: +12V Fan Connector Pinouts

4.2.4 Front Panel Connector (14-pin)

CN Label:	F_PANEL1
CN Type:	12-pin header (2x6)
CN Location:	See Figure 4-5
CN Pinouts:	See Table 4-6

The front panel connector connects to external switches and indicators to monitor and controls the motherboard. These indicators and switches include:

- Power LED

- Speaker
- Power button
- Reset
- HDD LED

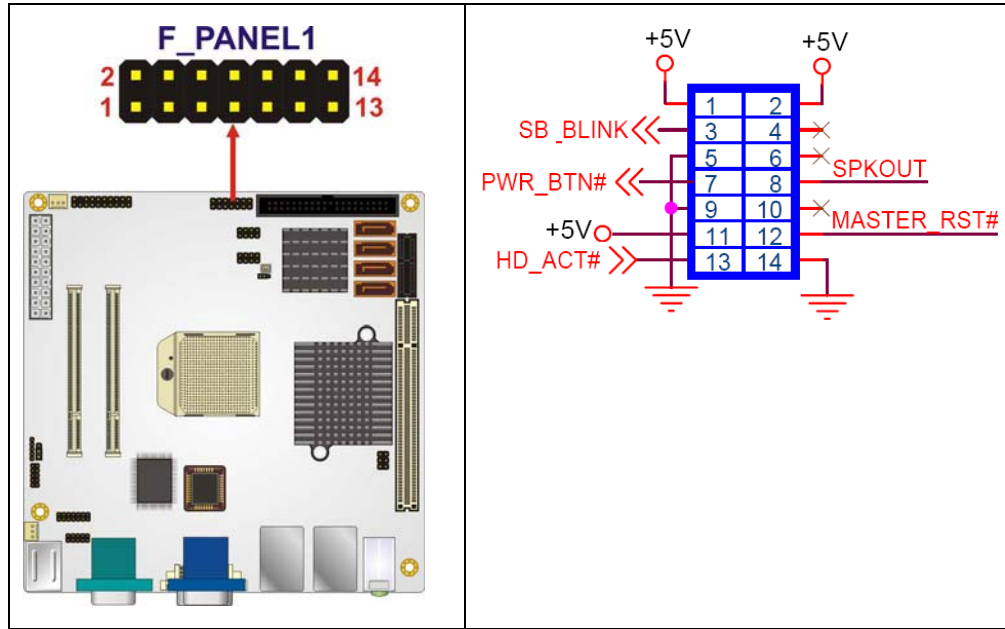

Figure 4-5: Front Panel Connector Pinout Locations (14-pin)

FUNCTION	PIN	DESCRIPTION	FUNCTION	PIN	DESCRIPTION
Power LED	1	LED+	Speaker	2	SPEAKER+
	3	BLINK		4	N/C
Power Button	5	GND		6	N/C
	7	PWRBTSW+		8	SPEAKER -
HDD LED	9	GND	Reset	10	N/C
	11	IDE LED+		12	RESET+
	13	IDE LED-		14	GND

Table 4-6: Front Panel Connector Pinouts (14-pin)

KINO-690S1 Mini-ITX Motherboard

4.2.5 IDE Connector (40-pin)

- CN Label:** IDE1
- CN Type:** 40-pin header (2x20)
- CN Location:** See Figure 4-6
- CN Pinouts:** See Table 4-7

One 40-pin IDE device connector on the KINO-690S1 supports connectivity to two hard disk drives.

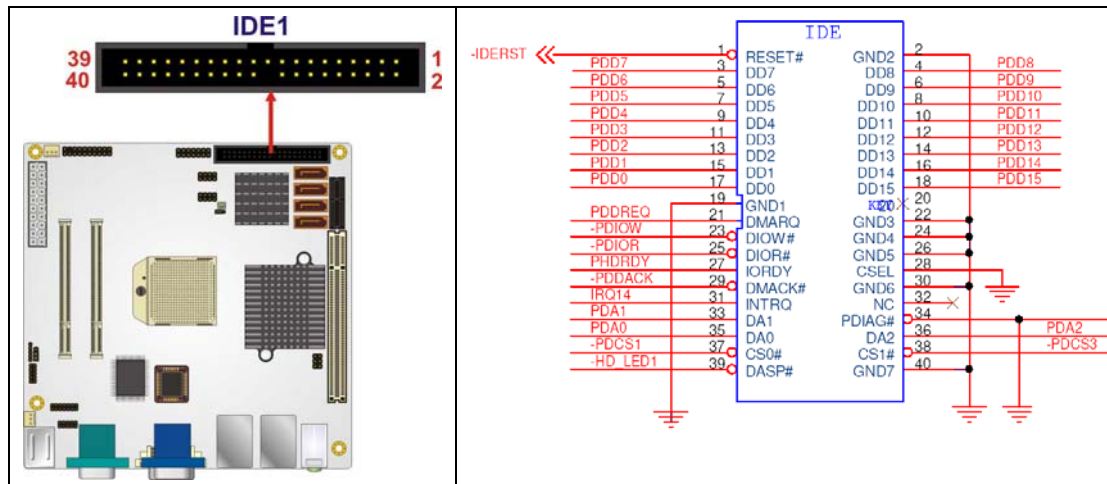

Figure 4-6: IDE Device Connector Locations

PIN NO.	DESCRIPTION	PIN NO.	DESCRIPTION
1	RESET#	2	GROUND
3	DATA 7	4	DATA 8
5	DATA 6	6	DATA 9
7	DATA 5	8	DATA 10
9	DATA 4	10	DATA 11
11	DATA 3	12	DATA 12
13	DATA 2	14	DATA 13
15	DATA 1	16	DATA 14
17	DATA 0	18	DATA 15

19	GROUND	20	N/C
21	IDE DRQ	22	GROUND
23	IOW#	24	GROUND
25	IOR#	26	GROUND
27	IDE CHRDY	28	GROUND
29	IDE DACK	30	GROUND-DEFAULT
31	INTERRUPT	32	N/C
33	SA1	34	N/C
35	SA0	36	SA2
37	HDC CS0#	38	HDC CS1#
39	HDD ACTIVE#	40	GROUND

Table 4-7: IDE Connector Pinouts

4.2.6 Infrared Interface Connector (5-pin)

- CN Label:** IR1
- CN Type:** 5-pin header (1x5)
- CN Location:** See Figure 4-7
- CN Pinouts:** See Table 4-8

The infrared interface connector supports both Serial Infrared (SIR) and Amplitude Shift Key Infrared (ASKIR) interfaces.

KINO-690S1 Mini-ITX Motherboard

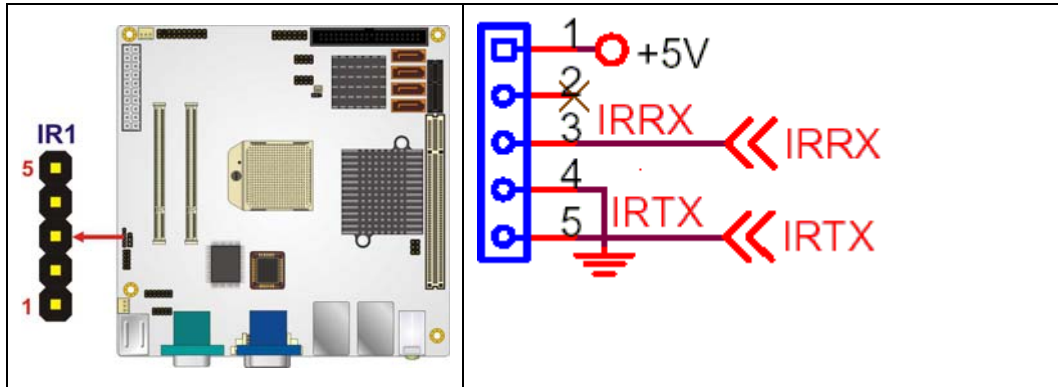

Figure 4-7: Infrared Connector Pinout Locations

PIN NO.	DESCRIPTION
1	VCC
2	NC
3	IR-RX
4	GND
5	IR-TX

Table 4-8: Infrared Connector Pinouts

4.2.7 PCI Slot

CN Label:	PCI1
CN Type:	PCI Slot
CN Location:	See Figure 4-8
CN Pinouts:	See Table 4-9

The PCI slot enables a PCI expansion module to be connected to the board.

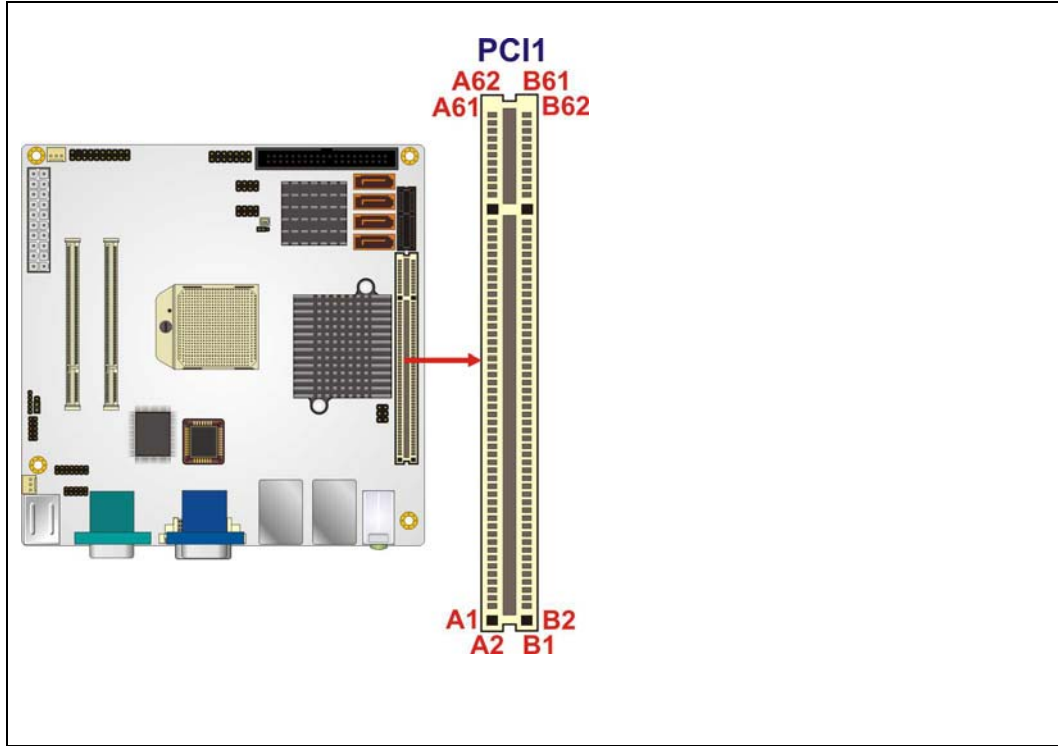

KINO-690S1 Mini-ITX Motherboard

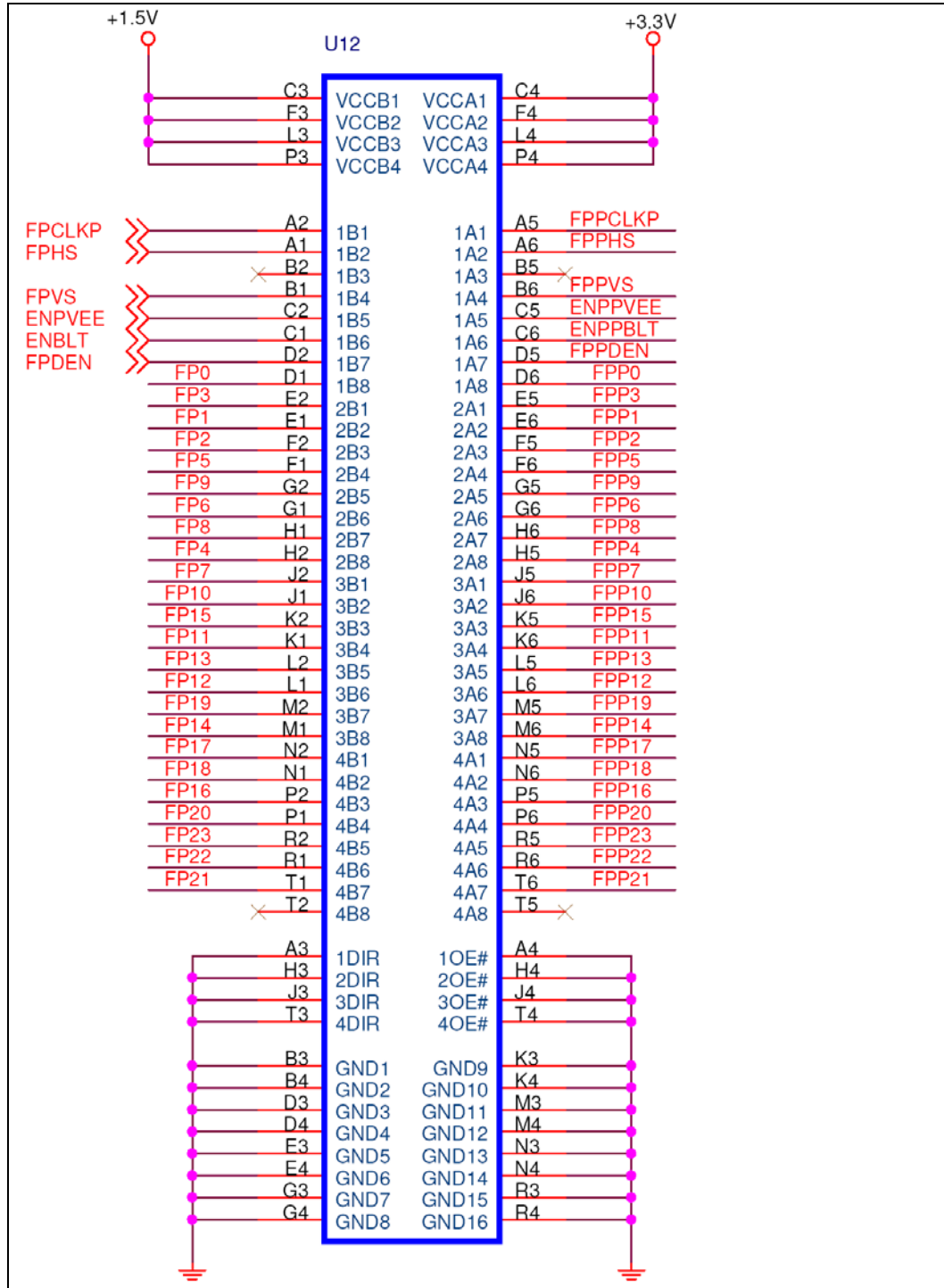

Figure 4-8: PCI Slot Location

PIN NO.	DESCRIPTION	PIN NO.	DESCRIPTION
A1	TRST	B1	-12V
A2	+12V	B2	TCK
A3	TMS	B3	GND
A4	TDI	B4	TDO
A5	+5V	B5	+5V
A6	INTA	B6	+5V
A7	INTC	B7	INTB
A8	+5V	B8	INTD
A9	RESERVED3	B9	PRSNT1
A10	+5V	B10	RESERVED1
A11	RESERVED4	B11	PRSNT2
A12	GND	B12	GND
A13	GND	B13	GND
A14	3.3V_AUX	B14	RESERVED2
A15	RST	B15	GND
A16	+5V	B16	CLK
A17	GNT	B17	GND
A18	GND	B18	REQ
A19	PME	B19	+5V
A20	AD30	B20	AD31
A21	+3.3V	B21	AD29
A22	AD28	B22	GND
A23	AD26	B23	AD27
A24	GND	B24	AD25
A25	AD24	B25	+3.3V
A26	IDSEL	B26	C/BE3
A27	+3.3V	B27	AD23
A28	AD22	B28	GND
A29	AD20	B29	AD21
A30	GND	B30	AD19
A31	AD18	B31	+3.3V

KINO-690S1 Mini-ITX Motherboard

A32	AD16	B32	AD17
A33	+3.3V	B33	C/BE2
A34	FRAME	B34	GND
A35	GND	B35	IRDY
A36	TRDY	B36	+3.3V
A37	GND	B37	DEVSEL
A38	STOP	B38	GND
A39	+3.3V	B39	LOCK
A40	SDONE	B40	PERR
A41	SBO	B41	+3.3V
A42	GND	B42	SERR
A43	PAR	B43	+3.3V
A44	AD15	B44	C/BE1
A45	+3.3V	B45	AD14
A46	AD13	B46	GND
A47	AD11	B47	AD12
A48	GND	B48	AD10
A49	AD9	B49	GND
A52	C/BE0	B52	AD8
A53	+3.3V	B53	AD7
A54	AD6	B54	+3.3V
A55	AD4	B55	AD5
A56	GND	B56	AD3
A57	AD2	B57	GND
A68	AD0	B68	AD1
A59	+5V	B59	+5V
A60	REQ64	B60	ACK64
A61	+5V	B61	+5V
A62	+5V	B62	+5V

Table 4-9: PCI Slot

4.2.8 PCI Express x1 Slot

- CN Label:** PCIE_2, PCIE_3
- CN Type:** 10-pin header (2x5)
- CN Location:** See Figure 4-9
- CN Pinouts:** See Table 4-10

PCIe x1 expansion devices can be inserted into the PCIe x1 slots.

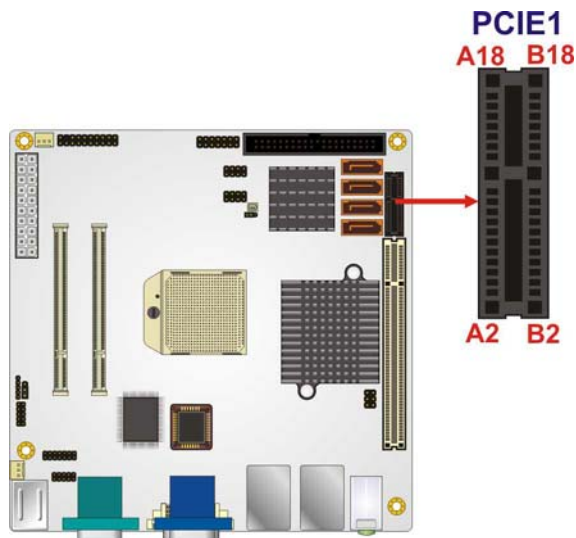

KINO-690S1 Mini-ITX Motherboard

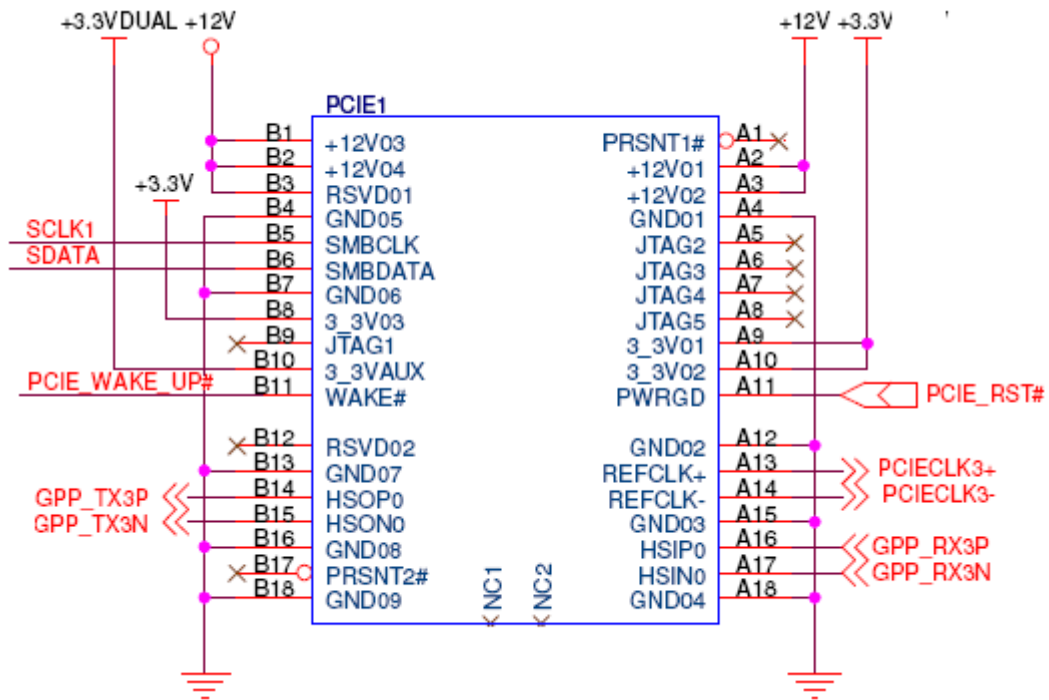

Figure 4-9: PCI Express x1 Slot Locations

PIN NO.	DESCRIPTION	PIN NO.	DESCRIPTION
A1	NC	B1	+12v
A2	+12v	B2	+12v
A3	+12v	B3	+12v
A4	GND	B4	GND
A5	NC	B5	SCLOCK
A6	NC	B6	SDATA
A7	NC	B7	GND
A8	NC	B8	+3.3v
A9	+3.3v	B9	NC
A10	+3.3v	B10	+3.3v Dual
A11	PCIE RST	B11	PCIE WAKEUP
A12	GND	B12	NC
A13	PCIE CLOCK+	B13	GND
A14	PCIE CLOCK-	B14	GPP_TX3P

A15	GND	B15	GPP_TX3N
A16	GPP_RX3P	B16	GND
A17	GPP_RX3N	B17	N/C
A18	GND	B18	GND

Table 4-10: PCI Express x1 Slot Pinouts

4.2.9 SATA Drive Connectors

CN Label: SATA1, SATA2, SATA3, and SATA4

CN Type: 7-pin SATA drive connectors

CN Location: See Figure 4-10

CN Pinouts: See Table 4-11

The two SATA drive connectors are each connected to a first generation SATA drive. First generation SATA drives transfer data at speeds as high as 150Mb/s. The SATA drives can be configured in a RAID configuration.

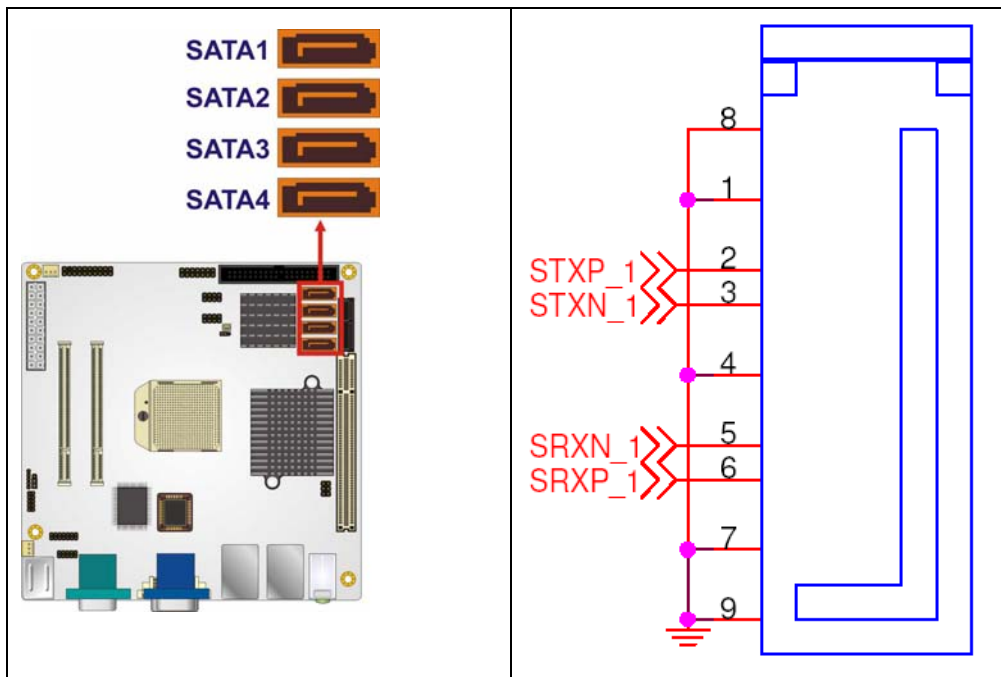
Figure 4-10: SATA Drive Connector Locations

KINO-690S1 Mini-ITX Motherboard

PIN NO.	DESCRIPTION
1	GND
2	TX+
3	TX-
4	GND
5	RX-
6	RX+
7	GND

Table 4-11: SATA Drive Connector Pinouts

4.2.10 Serial Port Connector (COM3)

CN Label:	COM3
CN Type:	10-pin header (2x5)
CN Location:	See Figure 4-11
CN Pinouts:	See Table 4-12

The 10-pin serial port connector provides a second RS-232 serial communications channel. The COM3 serial port connector can be connected to external RS-232 serial port devices.

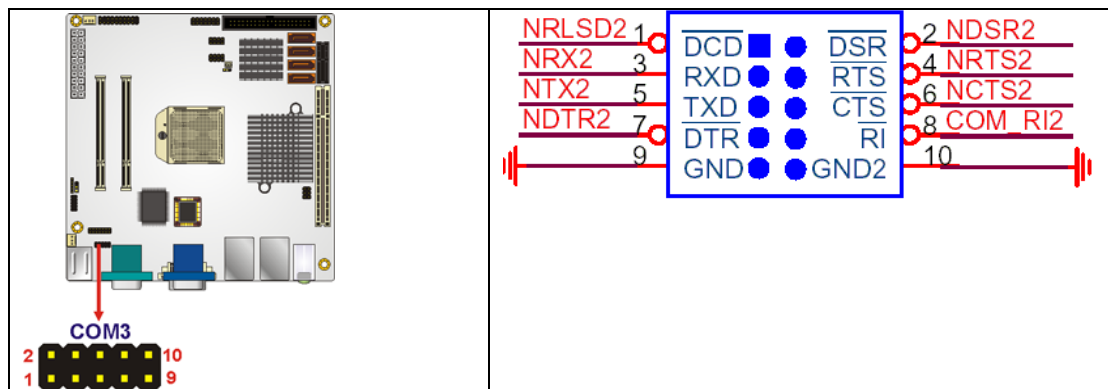

Figure 4-11: Serial Connector Pinout Locations

PIN NO.	DESCRIPTION	PIN NO.	DESCRIPTION
1	Data Carrier Direct (DCD)	2	Data Set Ready (DSR)

3	Receive Data (RXD)	4	Request To Send (RTS)
5	Transmit Data (TXD)	6	Clear To Send (CTS)
7	Data Terminal Ready (DTR)	8	Ring Indicator (RI)
9	Ground (GND)	10	Ground (GND)

Table 4-12: Serial Connector Pinouts

4.2.11 Serial Port Connector (COM4)(RS-232, RS-422 or RS-485)

- CN Label:** COM4
- CN Type:** 14-pin header (2x7)
- CN Location:** See Figure 4-12
- CN Pinouts:** See Table 4-13

The 14-pin serial port connector connects to the COM 2 serial communications channels. COM 2 is a multi function channel. In default mode COM 2 is an RS-232 serial communication channel but, with the COM 2 function select jumper, can be configured as either an RS-422 or RS-485 serial communications channel.

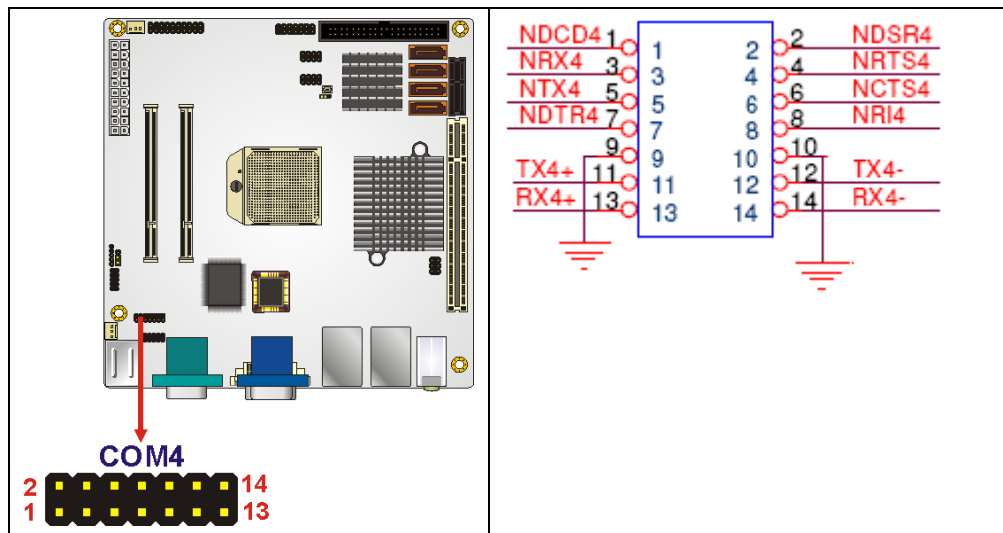
Figure 4-12: RS-232/422/485 Serial Port Connector Location

KINO-690S1 Mini-ITX Motherboard

PIN NO.	DESCRIPTION	PIN NO.	DESCRIPTION
1	DCD	2	NDSR2
3	RXD	4	NRTS2
5	TXD	6	NCTS2
7	DTR	8	NRI2
9	GND	10	GND
11	TXD85+	12	TXD485#
13	RXD85+	14	RXD485#

Table 4-13: RS-232/RS-485 Serial Port Connector Pinouts

4.2.12 Trusted Platform Module (TPM) Connector

- CN Label:** TPM1
- CN Type:** 40-pin header (2x20)
- CN Location:** See Figure 4-14
- CN Pinouts:** See Table 4-15

The Trusted Platform Module (TPM) connector secures the system on bootup. An optional TPM (see packing list in **Chapter 3**) can be connected to the TPM connector.

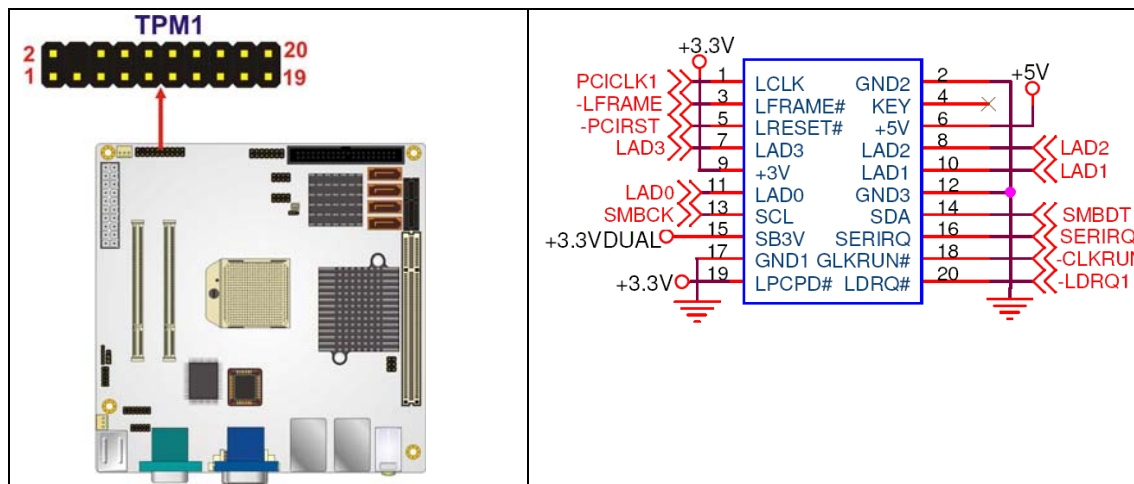

Figure 4-13: TPM Connector Pinout Locations

PIN NO.	DESCRIPTION	PIN NO.	DESCRIPTION
1	LCLK	2	GND2
3	LFRAME#	4	KEY
5	LRESET#	6	+5V
7	LAD3	8	LAD2
9	+3V	10	LAD1
11	LAD0	12	GND3
13	SCL	14	SDA
15	SB3V	16	SERIRQ
17	GND1	18	GLKRUN#
19	LPCPD#	20	LDRQ#

Table 4-14: TPM Connector Pinouts

4.2.13 TV Out Connector

- CN Label:** TV1
- CN Type:** 6-pin header (2x3)
- CN Location:** See Figure 4-14
- CN Pinouts:** See Table 4-15

The 2x3 pin TV out connector connects to a TV output by using an S-Video or RCA connector. The TV out connector makes displaying media data on a television easier.

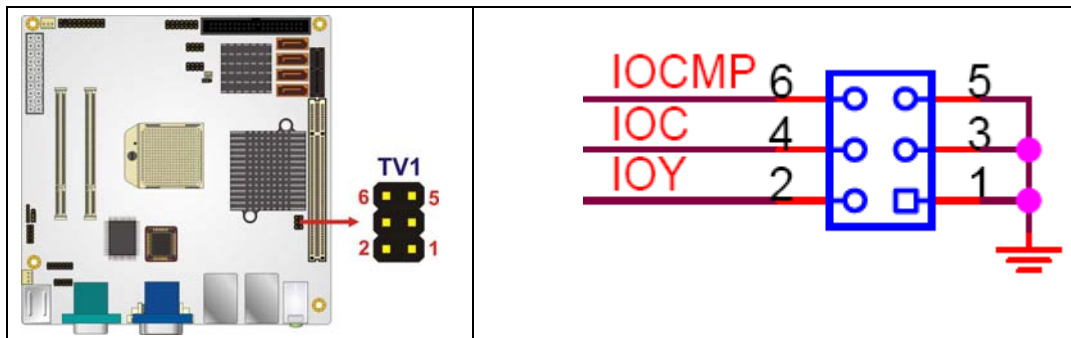
Figure 4-14: TV Connector Pinout Locations

KINO-690S1 Mini-ITX Motherboard

S-Video Connector			
PIN NO.	DESCRIPTION	PIN NO.	DESCRIPTION
1	GND	2	Luminance (Y)
3	GND	4	Chrominance (Pr)
5	GND	6	Chrominance (Pb)

Table 4-15: TV Port Connector Pinouts

4.2.14 USB Connectors (Internal)

CN Label: JUSB1 and JUSB2

CN Type: 8-pin header (2x4)

CN Location: See Figure 4-15

CN Pinouts: See Table 4-16

The 2x4 USB pin connectors each provide connectivity to two USB 1.1 or two USB 2.0 ports. Each USB connector can support two USB devices. Additional external USB ports are found on the rear panel. The USB ports are used for I/O bus expansion.

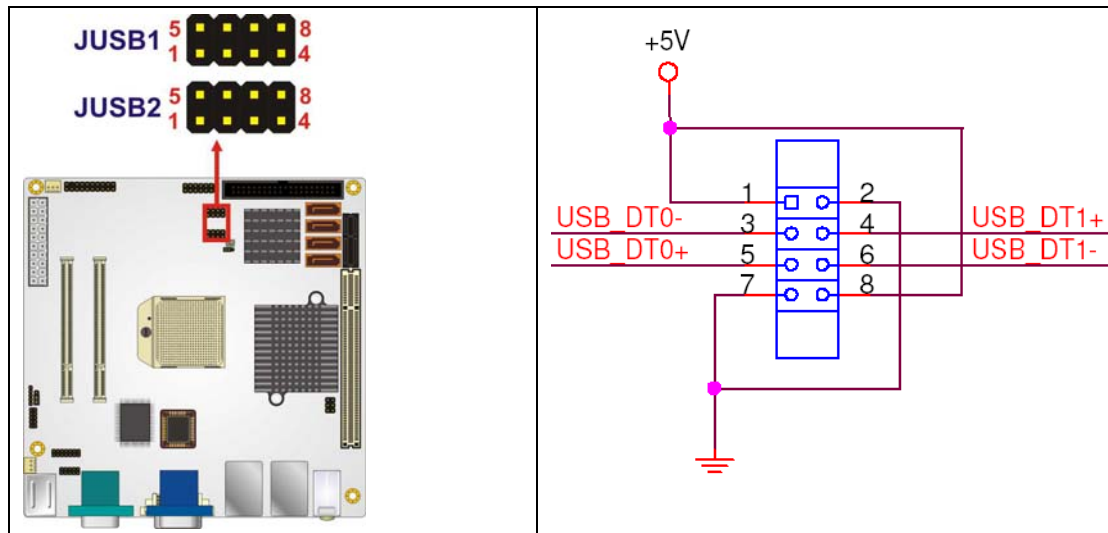

Figure 4-15: USB Connector Pinout Locations

PIN NO.	DESCRIPTION	PIN NO.	DESCRIPTION
1	VCC	2	GND
3	DATAN-	4	DATAM+
5	DATAN+	6	DATAM-
7	GND	8	VCC

Table 4-16: USB Port Connector Pinouts

4.3 External Peripheral Interface Connector Panel

Figure 4-16 shows the KINO-690S1 external peripheral interface connector (EPIC) panel.

The KINO-690S1 EPIC panel consists of the following:

- 3 x Audio jack connectors
- 1 x DVI connector
- 2 x PS/2 connectors
- 2 x RJ-45 LAN connectors
- 2 x RS-232 serial port connectors
- 4 x USB 2.0 connectors
- 1 x VGA connector

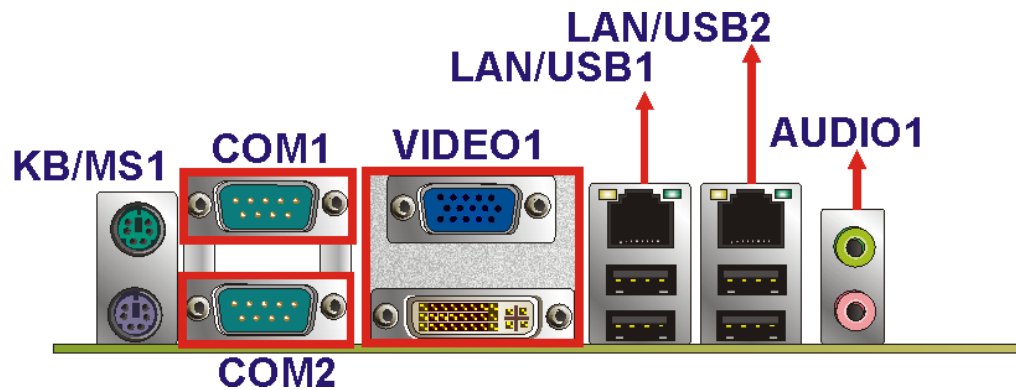

Figure 4-16: KINO-690S1 External Peripheral Interface Connector

4.3.1 Audio Connector

- CN Label:** CN8
- CN Type:** 3 x audio jacks

KINO-690S1 Mini-ITX Motherboard

CN Location: See Figure 4-16

The three audio jacks on the external audio connector enable the KINO-690S1 to be connected to external audio devices as specified below.

- **Line Out port (Lime):** Connects to a headphone or a speaker. With multi-channel configurations, this port can also connect to front speakers.
- **Microphone (Pink):** Connects a microphone.



Figure 4-17: Audio Connector

4.3.2 DVI and VGA Combo Connector

CN Label: VIDEO1
CN Type: DVI-D and DB-15
CN Location: See Figure 4-16
CN Pinouts: See Table 4-17 (DVI-D)

A 24-pin Digital Visual Interface (DVI) connector and a female DB-15 VGA connector are integrated into a single EPIC connector as shown in **Figure 4-16**.

The DVI connector connects to high-speed, high-resolution digital displays. The DVI-D connector supports both digital and analog signals. The connector is shown in **Figure 4-18** and the pinouts are shown in **Table 4-17**.

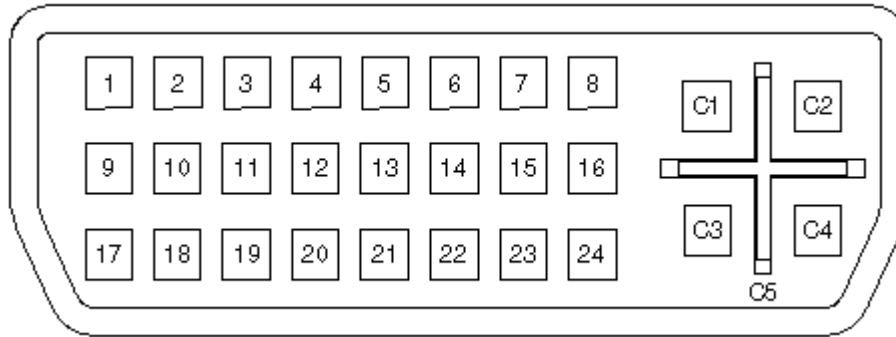
Figure 4-18: DVI-D Connector Pinouts

PIN	Signal Name	Pin #	Signal Name	Pin #	Signal Name
1	TMDS Data2-	9	TMDS Data1-	17	TMDS Data0-
2	TMDS Data2+	10	TMDS Data1+	18	TMDS Data0+
3	GND	11	GND	19	GND
4	N/C	12	NC	20	NC
5	N/C	13	NC	21	NC
6	DDC Clock [SCL]	14	PVDD1	22	GND
7	DDC Data [SDA]	15	GND	23	TMDS Clock +
8	Analog vertical sync	16	GND	24	TMDS Clock -
C1	N/C	--	--	--	--
C2	N/C	--	--	--	--
C3	N/C	--	--	--	--
C4	N/C	--	--	--	--
C5	N/C	--	--	--	--

Table 4-17: DVI-D Connector Pinouts

The female DB-15 VGA connector connects to standard VGA displays. The connector is shown in **Figure 4-19** and the pinouts are shown in **Table 4-18**.

KINO-690S1 Mini-ITX Motherboard

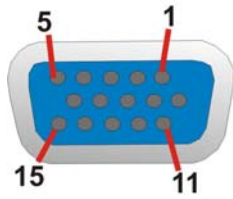

Figure 4-19: VGA Connector

PIN	DESCRIPTION	PIN	DESCRIPTION
1	RED	2	GREEN
3	BLUE	4	NC
5	GND	6	GND
7	GND	8	GND
9	VCC / NC	10	GND
11	NC	12	DDC DAT
13	HSYNC	14	VSYNC
15	DDCCLK		

Table 4-18: VGA Connector Pinouts

4.3.3 Keyboard/Mouse Connector

- CN Label: CN1
- CN Type: Dual PS/2
- CN Location: See Figure 4-16
- CN Pinouts: See Figure 4-20

The KINO-690S1 keyboard and mouse connectors are standard PS/2 connectors.

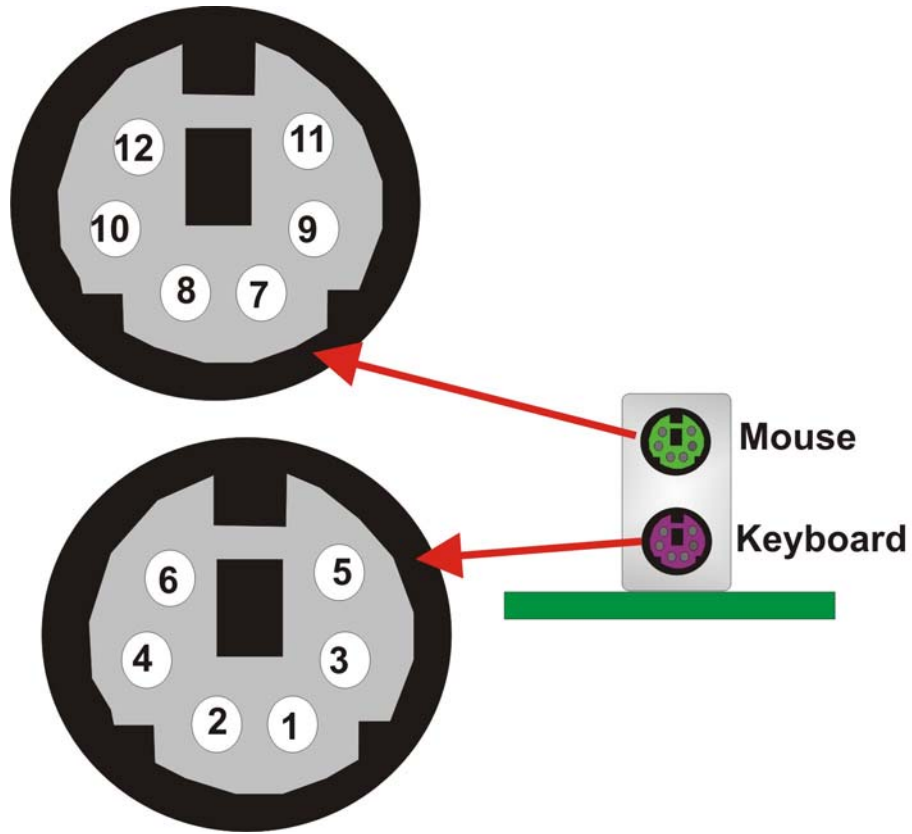

Figure 4-20: PS/2 Pinouts

PIN	DESCRIPTION	PIN	DESCRIPTION
1	L_KDAT	7	L_MDAT
2	NC	8	NC
3	GND	9	GND
4	5V	10	5V
5	L_KCLK	11	L_MCLK
6	NC	12	NC

Table 4-19: PS/2 Connector Pinouts

4.3.4 LAN Connectors

CN Label: J20 and J21

CN Type: RJ-45

KINO-690S1 Mini-ITX Motherboard

CN Location: See Figure 4-16

CN Pinouts: See Table 4-20

The KINO-690S1 is equipped with two built-in RJ-45 Ethernet controllers. The controllers can connect to the LAN through two RJ-45 LAN connectors. There are two LEDs on the connector indicating the status of LAN. The pin assignments are listed in the following table:

PIN	DESCRIPTION	PIN	DESCRIPTION
1	TXA+	5	TXC-
2	TXA-	6	TXB-
3	TXB+	7	TXD+
4	TXC+	8	TXD-

Table 4-20: LAN Pinouts

Activity Linked

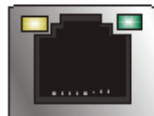

Figure 4-21: RJ-45 Ethernet Connector

The RJ-45 Ethernet connector has two status LEDs, one green and one yellow. The green LED indicates activity on the port and the yellow LED indicates the port is linked. See **Table 4-21**.

STATUS	DESCRIPTION	STATUS	DESCRIPTION
ORANGE	10/100 LAN	YELLOW	Linked
GREEN	GbE LAN		

Table 4-21: RJ-45 Ethernet Connector LEDs

4.3.5 Serial Port Connectors (COM1 and COM2)

- CN Label:** COM1 and COM2
- CN Type:** DB-9 connectors
- CN Location:** See Figure 4-16 (see 2)
- CN Pinouts:** See Table 4-22 and Figure 4-22

Two serial port connectors, COM1 and COM2, are externally accessible. The 9-pin DB-9 serial port connectors are connected to RS-232 serial communications devices.

PIN NO.	DESCRIPTION	PIN NO.	DESCRIPTION
1	DCD	6	DSR
2	RX	7	RTS
3	TX	8	CTS
4	DTR	9	RI
5	GND		

Table 4-22: RS-232 Serial Port Pinouts

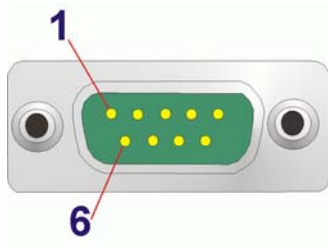

Figure 4-22: Pinout Locations

4.3.6 USB Connector

- CN Label:** LAN/USB1 and LAN/USB2
- CN Type:** USB port
- CN Location:** See **Figure 4-16**

KINO-690S1 Mini-ITX Motherboard

CN Pinouts: See Table 4-23

The KINO-690S1 has four external USB 2.0 ports. The ports are integrated into two dual USB and LAN combo connectors. The USB ports connect to both USB 2.0 and USB 1.1 devices.

PIN NO.	DESCRIPTION
1	+5V
2	USB_PN
3	USB_PP
4	GND

Table 4-23: USB Port Pinouts

THIS PAGE IS INTENTIONALLY LEFT BLANK

Chapter

5

Installation

5.1 Anti-static Precautions



WARNING:

Failure to take ESD precautions during the installation of the KINO-690S1 may result in permanent damage to the KINO-690S1 and severe injury to the user.

Electrostatic discharge (ESD) can cause serious damage to electronic components, including the KINO-690S1. Dry climates are especially susceptible to ESD. It is therefore critical that whenever the KINO-690S1, or any other electrical component is handled, the following anti-static precautions are strictly adhered to.

- **Wear an anti-static wristband:** - Wearing a simple anti-static wristband can help to prevent ESD from damaging the board.
- **Self-grounding:** - Before handling the board touch any grounded conducting material. During the time the board is handled, frequently touch any conducting materials that are connected to the ground.
- **Use an anti-static pad:** When configuring the KINO-690S1, place it on an anti-static pad. This reduces the possibility of ESD damaging the KINO-690S1.
- **Only handle the edges of the PCB:-:** When handling the PCB, hold the PCB by the edges.

5.2 Installation Considerations



NOTE:

The following installation notices and installation considerations should be read and understood before the KINO-690S1 is installed. All installation notices pertaining to the installation of the KINO-690S1 should be strictly adhered to. Failing to adhere to these precautions may lead to severe damage of the KINO-690S1 and injury to the person installing the motherboard.

5.2.1 Installation Notices



WARNING:

The installation instructions described in this manual should be carefully followed in order to prevent damage to the KINO-690S1, KINO-690S1 components and injury to the user.

Before and during the installation please **DO** the following:

- Read the user manual:
 - The user manual provides a complete description of the KINO-690S1 installation instructions and configuration options.
- Wear an electrostatic discharge cuff (ESD):
 - Electronic components are easily damaged by ESD. Wearing an ESD cuff removes ESD from the body and helps prevent ESD damage.
- Place the KINO-690S1 on an antistatic pad:
 - When installing or configuring the motherboard, place it on an antistatic pad. This helps to prevent potential ESD damage.
- Turn all power to the KINO-690S1 off:

- When working with the KINO-690S1, make sure that it is disconnected from all power supplies and that no electricity is being fed into the system.

Before and during the installation of the KINO-690S1 **DO NOT:**

- Remove any of the stickers on the PCB board. These stickers are required for warranty validation.
- Use the product before verifying all the cables and power connectors are properly connected.
- Allow screws to come in contact with the PCB circuit, connector pins, or its components.

5.2.2 Installation Checklist

The following checklist is provided to ensure the KINO-690S1 is properly installed.

- All the items in the packing list are present
- The CPU is installed
- The CPU cooling kit is properly installed
- A compatible memory module is properly inserted into the slot
- The CF Type I or CF Type II card is properly installed into the CF socket
- The jumpers have been properly configured
- The KINO-690S1 is inserted into a chassis with adequate ventilation
- The correct power supply is being used
- The following devices are properly connected
 - Primary and secondary IDE device
 - SATA drives
 - Audio kit
 - Power supply
 - USB cable
 - Serial port cable
- The following external peripheral devices are properly connected to the chassis:
 - DVI screen
 - Keyboard
 - Mouse

KINO-690S1 Mini-ITX Motherboard

- LAN
- VGA screen

5.3 Unpacking

5.3.1 Unpacking Precautions

When the KINO-690S1 is unpacked, please do the following:

- Follow the anti-static precautions outlined in **Section 5.1**.
- Make sure the packing box is facing upwards so the KINO-690S1 does not fall out of the box.
- Make sure all the components in the checklist shown in **Chapter 3** are present.



NOTE:

If some of the components listed in the checklist in **Chapter 3** are missing, please do not proceed with the installation. Contact the IEI reseller or vendor you purchased the KINO-690S1 from or contact an IEI sales representative directly. To contact an IEI sales representative, please send an email to sales@iei.com.tw.

5.4 CPU, CPU Cooling Kit and DIMM Installation



WARNING:

A CPU should never be turned on without the specified cooling kit being installed. If the cooling kit (heat sink and fan) is not properly installed and the system turned on, permanent damage to the CPU, KINO-690S1 and other electronic components attached to the system may be incurred. Running a CPU without a cooling kit may also result in injury to the user.

The CPU, CPU cooling kit and DIMM are the most critical components of the KINO-690S1. If one of these components is not installed the KINO-690S1 cannot run.

5.4.1 AMD Socket S1 CPU Installation



WARNING:

CPUs are expensive and sensitive components. When installing the CPU please be careful not to damage it in anyway. Make sure the CPU is installed properly and ensure the correct cooling kit is properly installed.

To install a AMD Socket S1 CPU onto the KINO-690S1, follow the steps below:



WARNING:

When handling the CPU, only hold it on the sides. DO NOT touch the pins at the bottom of the CPU.

KINO-690S1 Mini-ITX Motherboard

Step 1: **Unlock the CPU retention screw.** When shipped, the retention screw of the CPU socket should be in the unlocked position. If it is not in the unlocked position, use a screwdriver to unlock the screw. See **Figure 5-1**.

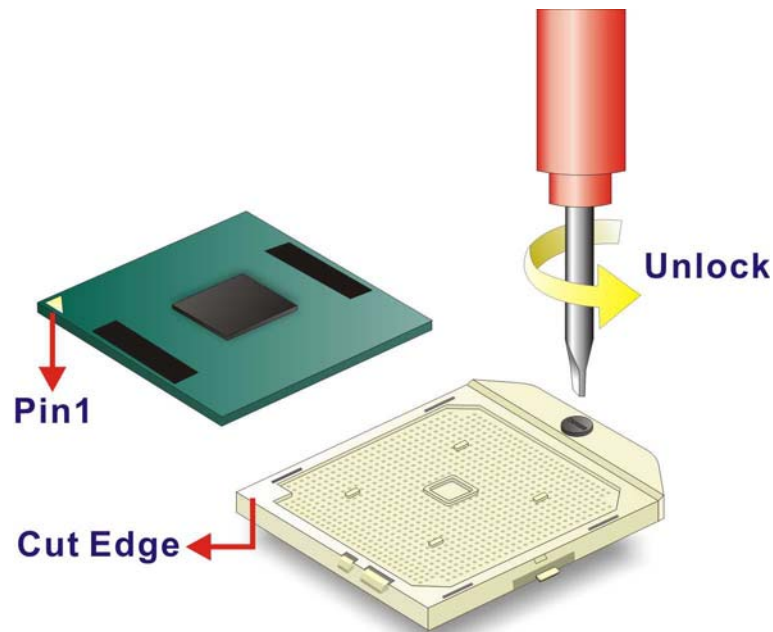

Figure 5-1: Make sure the CPU socket retention screw is unlocked

- Step 2:** **Inspect the CPU socket.** Make sure there are no bent pins and make sure the socket contacts are free of foreign material. If any debris is found, remove it with compressed air.
- Step 3:** **Correctly Orientate the CPU.** Make sure the IHS (integrated heat sink) side is facing upwards.
- Step 4:** **Correctly position the CPU.** Match the Pin 1 mark with the cut edge on the CPU socket. See **Figure 5-1**.
- Step 5:** **Align the CPU pins.** Carefully align the CPU pins with the holes in the CPU socket.
- Step 6:** **Insert the CPU.** Gently insert the CPU into the socket. If the CPU pins are properly aligned, the CPU should slide into the CPU socket smoothly.

Step 7: Lock the retention screw. Rotate the retention screw into the locked position.

5.4.2 Cooling Kit CF-479B-RS Installation



Figure 5-2: IEI CF-479B-RS Cooling Kit

An IEI AMD Socket S1 CPU cooling kit (**Figure 5-2**) can be purchased separately. The cooling kit comprises a CPU heat sink and a cooling fan.



WARNING:

Do not wipe off (accidentally or otherwise) the pre-sprayed layer of thermal paste on the bottom of the [Fan model#] heat sink. The thermal paste between the CPU and the heat sink is important for optimum heat dissipation.

To install the CF-479B-RS cooling kit, please follow the steps below.

Step 1: Place the cooling kit onto the CPU. Make sure the CPU cooling fan cable can be properly routed when the cooling kit is installed.

Step 2: Properly align the cooling kit. Make sure its four spring screw fasteners can pass through the pre-drilled holes on the PCB.

Step 3: Secure the cooling kit. From the solder side of the PCB, align the support bracket to the screw threads on heat sink that were inserted through the PCB

KINO-690S1 Mini-ITX Motherboard

holes. (See **Figure 5-3**)

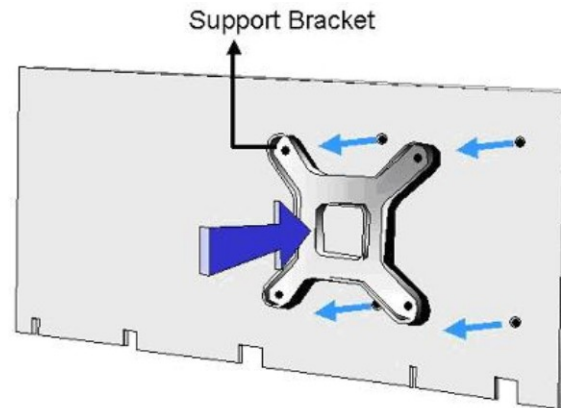

Figure 5-3: Cooling Kit Support Bracket

Step 4: Tighten the screws. Use a screwdriver to tighten the four screws. Tighten each nut a few turns at a time and do not over-tighten the screws.

Step 5: Connect the fan cable. Connect the cooling kit fan cable to the fan connector on the motherboard. Carefully route the cable and avoid heat generating chips and fan blades. See **Figure 5-4**.

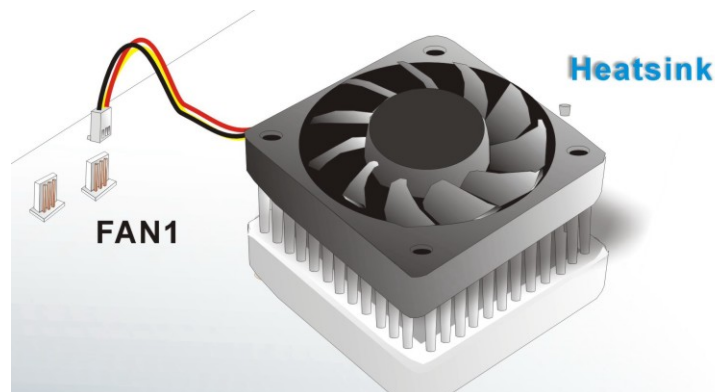

Figure 5-4: Connect the cooling fan cable

5.4.3 SO-DIMM Installation



WARNING:

Using incorrectly specified SO-DIMMs may permanently damage the KINO-690S1. Please make sure the purchased SO-DIMM complies with the memory specifications of the KINO-690S1. SO-DIMM specifications compliant with the KINO-690S1 are listed in **Chapter 2**.

To install a SO-DIMM into a SO-DIMM socket, please follow the steps below and refer to **Figure 5-5**.

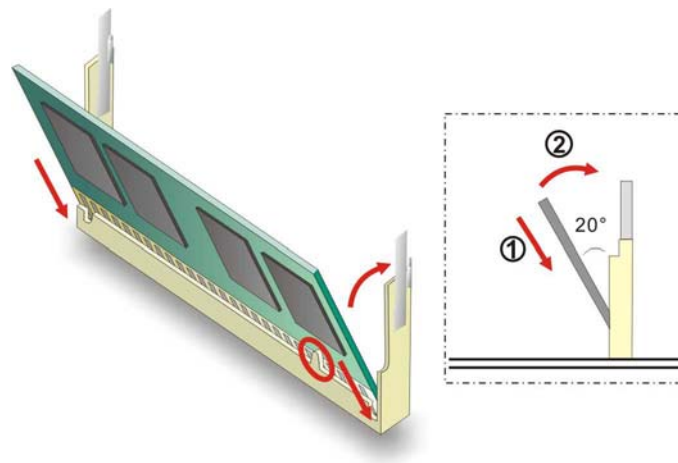

Figure 5-5: SO-DIMM Installation

- Step 1:** **Locate the SO-DIMM socket.** Place the KINO-690S1 on an anti-static pad with the solder side facing up.
- Step 2:** **Align the SO-DIMM with the socket.** The SO-DIMM must be oriented in such a way that the notch in the middle of the SO-DIMM must be aligned with the plastic bridge in the socket.
- Step 3:** **Insert the SO-DIMM.** Push the SO-DIMM chip into the socket at an angle. (See **Figure 5-5**)

KINO-690S1 Mini-ITX Motherboard

Step 4: Open the **SO-DIMM** socket arms. Gently pull the arms of the SO-DIMM socket out and push the rear of the SO-DIMM down. (See **Figure 5-5**)

Step 5: Secure the **SO-DIMM**. Release the arms on the SO-DIMM socket. They clip into place and secure the SO-DIMM in the socket.

5.5 Jumper Settings



NOTE:

A jumper is a metal bridge that is used to close an electrical circuit. It consists of two metal pins and a small metal clip (often protected by a plastic cover) that slides over the pins to connect them. To **CLOSE/SHORT** a jumper means connecting the pins of the jumper with the plastic clip and to **OPEN** a jumper means removing the plastic clip from a jumper.

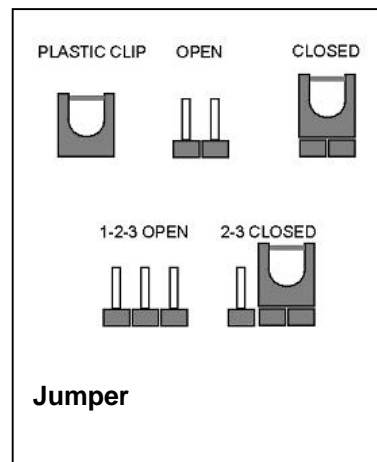

Before the KINO-690S1 is installed in the system, the jumpers must be set in accordance with the desired configuration. The jumpers on the KINO-690S1 are listed in **Table 5-1**.

Description	Label	Type
Clear CMOS	J2	3-pin header
RS-232/485 Setup for COM4	J1	3-pin header

Table 5-1: Jumpers

5.5.1 Clear CMOS Jumper

Jumper Label:	J2
Jumper Type:	3-pin header
Jumper Settings:	See Table 5-2
Jumper Location:	See Figure 5-6

If the KINO-690S1 fails to boot due to improper BIOS settings, the clear CMOS jumper clears the CMOS data and resets the system BIOS information. To do this, use the jumper cap to close pins 2 and 3 for a few seconds then reinstall the jumper clip back to pins 1 and 2.

If the “CMOS Settings Wrong” message is displayed during the boot up process, the fault may be corrected by pressing the F1 to enter the CMOS Setup menu. Do one of the following:

- Enter the correct CMOS setting
- Load Optimal Defaults
- Load Failsafe Defaults.

After having done one of the above, save the changes and exit the CMOS Setup menu.

The clear CMOS jumper settings are shown in **Table 5-2**.

Jumper Select	Description	
Short 1 - 2	Keep CMOS Setup	Default
Short 2 - 3	Clear CMOS Setup	

Table 5-2: Clear CMOS Jumper Settings

The location of the clear CMOS jumper is shown in **Figure 5-6** below.

KINO-690S1 Mini-ITX Motherboard

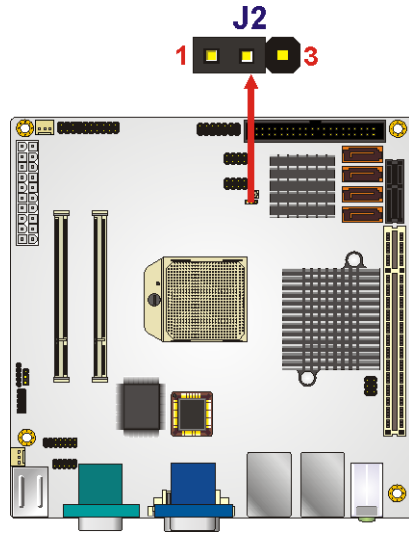

Figure 5-6: Clear CMOS Jumper

5.5.2 COM 4 Function Select Jumper

Jumper Label:	J1
Jumper Type:	3-pin header
Jumper Settings:	See Table 5-3
Jumper Location:	See Figure 5-7

The COM4 Function Select jumper sets the communication protocol used by the second serial communications port (COM4) as RS-232, RS-422 or RS-485. The COM4 Function Select settings are shown in **Table 5-3**.

COM 2 Function Select	Description	
Short 1-2	RS-232	Default
Short 2-3	RS-422/485	

Table 5-3: COM4 Function Select Jumper Settings

The COM4 Function Select jumper location is shown in **Figure 5-7**.

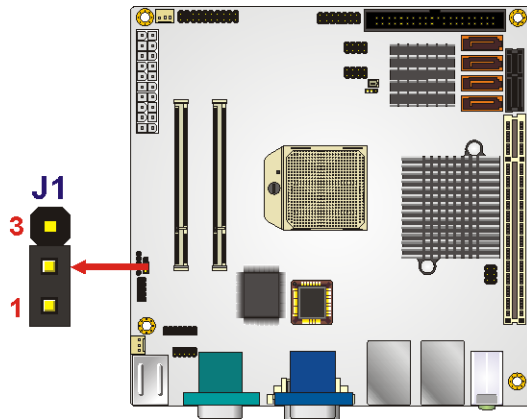

Figure 5-7: COM4 Function Select Jumper Location

5.6 Chassis Installation

5.6.1 Airflow



WARNING:

Airflow is critical to the cooling of the CPU and other onboard components. The chassis in which the KINO-690S1 must have air vents to allow cool air to move into the system and hot air to move out.

The KINO-690S1 must be installed in a chassis with ventilation holes on the sides allowing airflow to travel through the heat sink surface. In a system with an individual power supply unit, the cooling fan of a power supply can also help generate airflow through the board surface.

KINO-690S1 Mini-ITX Motherboard



NOTE:

IEI has a wide range of backplanes available. Please contact your KINO-690S1 vendor, reseller or an IEI sales representative at sales@iei.com.tw or visit the IEI website (<http://www.ieworld.com.tw>) to find out more about the available chassis.

5.6.2 Motherboard Installation

To install the KINO-690S1 motherboard into the chassis please refer to the reference material that came with the chassis.

5.7 Internal Peripheral Device Connections

5.7.1 Peripheral Device Cables

The cables listed in **Table 5-4** are shipped with the KINO-690S1.

Quantity	Type
1	ATA 66/100 flat cable
1	I/O shield
1	Dual RS-232 cable
2	SATA drive cables
1	SATA drive power cables
1	USB cable

Table 5-4: IEI Provided Cables

Separately purchased optional IEI items that can be installed are listed below:

- Audio kit
- FDD cable

- HDTV Cable Set
- LPT cable
- VGA D-Sub cable with bracket

For more details about the items listed above, please refer to **Chapter 3**. Installation of the accessories listed above are described in detail below.

5.7.2 ATA Flat Cable Connection

The ATA 66/100 flat cable connects to the KINO-690S1 to one or two IDE devices. To connect an IDE HDD to the KINO-690S1 please follow the instructions below.

Step 1: Locate the IDE connector. The location/s of the IDE device connector/s is/are shown in **Chapter 3**.

Step 2: Insert the connector. Connect the IDE cable connector to the onboard connector. See **Figure 5-8**. A key on the front of the cable connector ensures it can only be inserted in one direction.

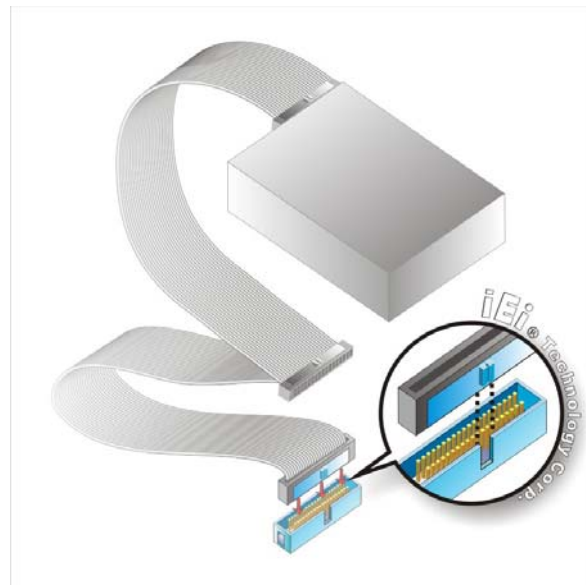

Figure 5-8: IDE Cable Connection

Step 3: Connect the cable to an IDE device. Connect the two connectors on the other

KINO-690S1 Mini-ITX Motherboard

side of the cable to one or two IDE devices. Make sure that pin 1 on the cable corresponds to pin 1 on the connector

5.7.3 Dual RS-232 Cable Connection

The dual RS-232 cable consists of two connectors attached to two independent cables. Each cable is then attached to a D-sub 9 male connector that is mounted onto a bracket. To install the dual RS-232 cable, please follow the steps below.

Step 1: Locate the connectors. The locations of the RS-232 connectors are shown in **Chapter 3**.

Step 2: Insert the cable connectors. Insert one connector into each serial port box headers. See **Figure 5-9**. A key on the front of the cable connectors ensures the connector can only be installed in one direction.

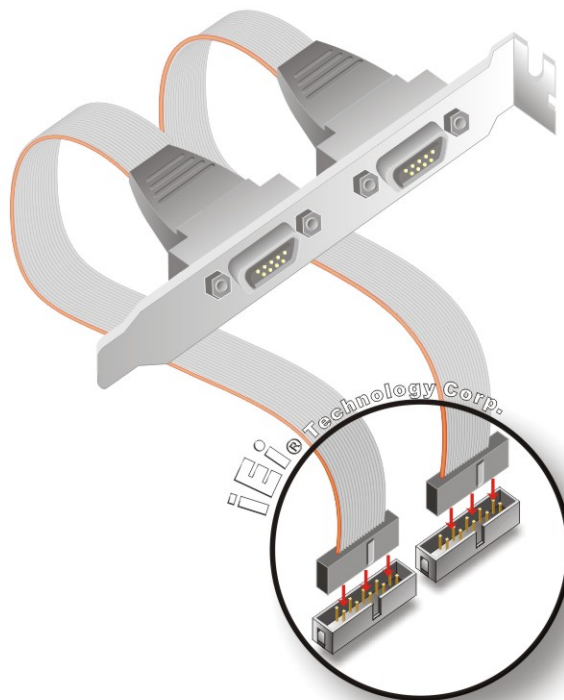

Figure 5-9: Dual RS-232 Cable Installation

Step 3: Secure the bracket. The dual RS-232 connector has two D-sub 9 male

connectors secured on a bracket. To secure the bracket to the chassis please refer to the reference material that came with the chassis **Step 0**:

5.7.4 SATA Drive Connection

The KINO-690S1 is shipped with two SATA drive cables and one SATA drive power cable. To connect the SATA drives to the connectors, please follow the steps below.

Step 1: Locate the connectors. The locations of the SATA drive connectors are shown in **Chapter 3**.

Step 2: Insert the cable connector. Press the clip on the connector at the end of the SATA cable and insert the cable connector into the onboard SATA drive connector. See **Figure 5-10**.

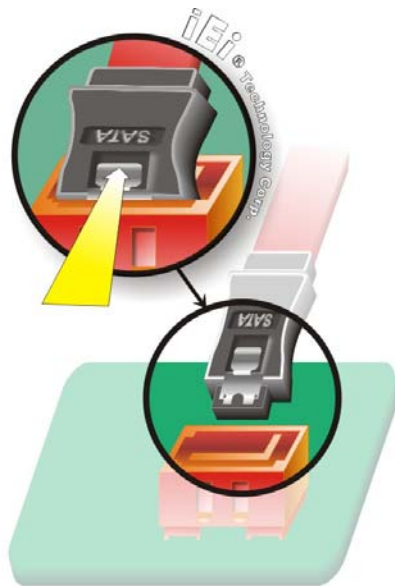

Figure 5-10: SATA Drive Cable Connection

Step 3: Connect the cable to the SATA disk. Connect the connector on the other end of the cable to the connector at the back of the SATA drive. See **Figure 5-11**.

Step 4: Connect the SATA power cable. Connect the SATA power connector to the

KINO-690S1 Mini-ITX Motherboard

back of the SATA drive. See **Figure 5-11. Step 0:**



Figure 5-11: SATA Power Drive Connection

5.7.5 USB Cable (Dual Port)

The KINO-690S1 is shipped with a dual port USB 2.0 cable. To connect the USB cable connector, please follow the steps below.

Step 1: Locate the connectors. The locations of the USB connectors are shown in **Chapter 3.**



WARNING:

If the USB pins are not properly aligned, the USB device can burn out.

Step 2: Align the connectors. The cable has two connectors. Correctly align pin 1 on each cable connector with pin 1 on the KINO-690S1 USB connector.

Step 3: Insert the cable connectors. Once the cable connectors are properly aligned with the USB connectors on the KINO-690S1, connect the cable connectors to the onboard connectors. See **Figure 5-12.**

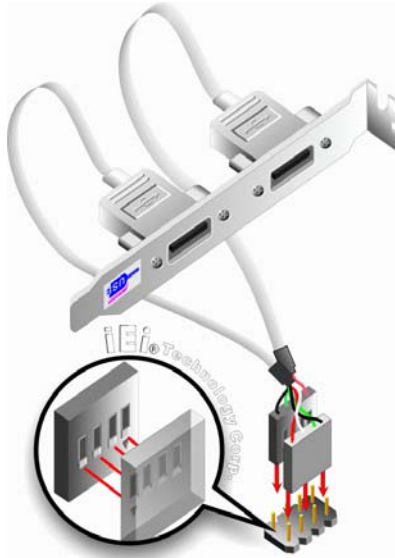

Figure 5-12: Dual USB Cable Connection

Step 4: **Attach the bracket to the chassis.** The USB 2.0 connectors are attached to a bracket. To secure the bracket to the chassis please refer to the installation instructions that came with the chassis.

5.7.6 USB Cable (Four Port)

Four port USB 2.0 cables can be separately purchased from IEI. To install a four port USB cable onto the KINO-690S1, please follow the steps below.

Step 1: **Locate the connectors.** The locations of the USB connectors are shown in Chapter 4.



WARNING:

If the USB pins are not properly aligned, the USB device can burn out.

Step 2: **Align the connectors.** Each cable has two connectors. Correctly align pin 1 on each cable connector with pin 1 on the KINO-690S1 USB connectors.

KINO-690S1 Mini-ITX Motherboard

Step 3: Insert the cable connectors. Once the cable connectors are properly aligned with the USB connectors on the KINO-690S1, connect the cable connectors to the onboard connectors. See **Figure 5-13**.

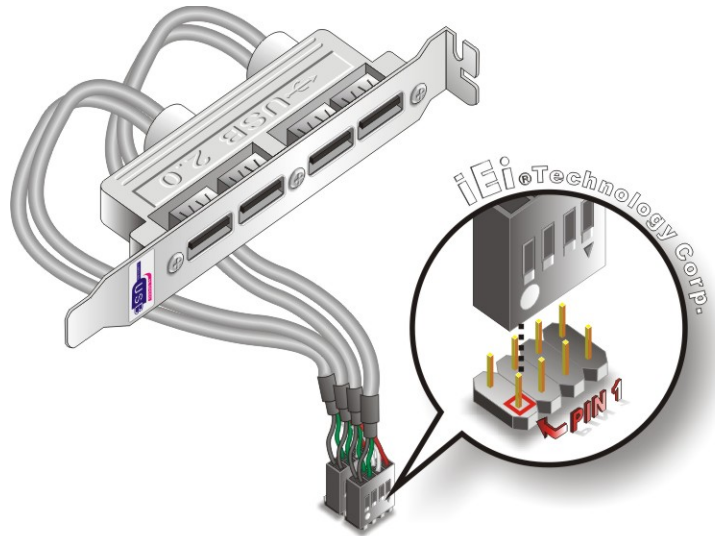

Figure 5-13: Four Port USB Cable Connection

Step 4: Attach the bracket to the chassis. The USB 2.0 connectors are attached to a bracket. To secure the bracket to the chassis please refer to the installation instructions that came with the chassis.

5.8 External Peripheral Interface Connection

The following external peripheral devices can be connected to the external peripheral interface connectors.

- Audio jacks
- DVI display
- PS/2 keyboard and mouse
- RJ-45 Ethernet cable connectors
- Serial ports
- USB ports
- VGA screen

To install these devices, connect the corresponding cable connector from the actual device to the corresponding KINO-690S1 external peripheral interface connector making sure the pins are properly aligned.

5.8.1 Audio Connection

Audio signals are interfaced through three phone jack connections. The red phone jack is for Mic In, blue is for Line In and green is for Speaker Out. Follow the steps below to connect audio devices to the KINO-690S1.

Step 1: Locate the audio phone jacks. The location of the audio phone jacks are shown in **Chapter 3**.

Step 2: Insert audio phone jack plugs. Insert audio phone jack plugs into the audio phone jacks on the external peripheral interface. See Figure 5-14.

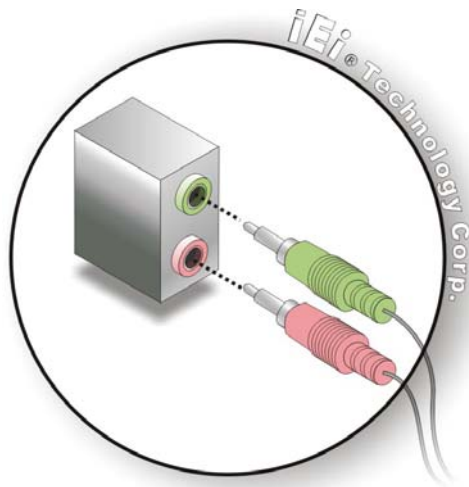

Figure 5-14: Audio Connectors

5.8.2 DVI Display Device Connection

The KINO-690S1 has a single female DVI connector on the external peripheral interface panel. The DVI connector is connected to a digital display device. To connect a digital display device to the KINO-690S1, please follow the instructions below.

Step 1: Locate the DVI connector. The location of the DVI connector is shown in

KINO-690S1 Mini-ITX Motherboard

Chapter 2.

- Step 2: Align the DVI connector.** Align the male DVI connector on the digital display device cable with the female DVI connector on the external peripheral interface.
- Step 3: Insert the DVI connector** Once the connectors are properly aligned with the male connector, insert the male connector from the digital display device into the female connector on the KINO-690S1. See **Figure 5-15**.

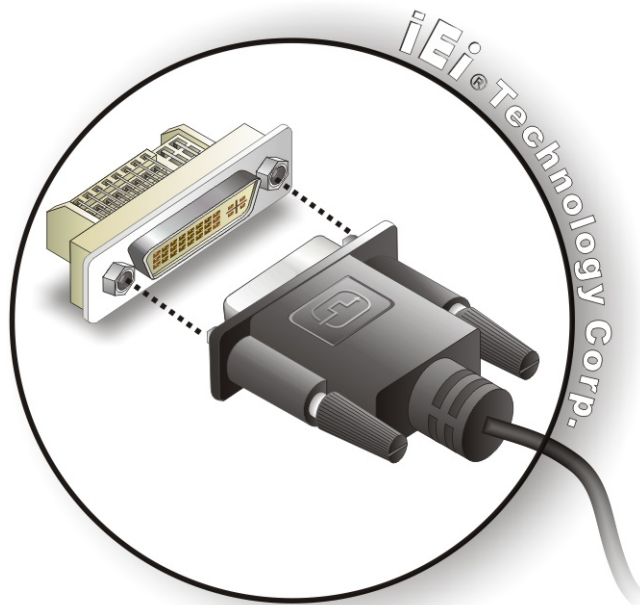

Figure 5-15: DVI Connector

- Step 4: Secure the connector.** Secure the DVI connector from the digital display device to the external interface by tightening the two retention screws on either side of the connector.

5.8.3 LAN Connection (Single Connector)

There are two external RJ-45 LAN connectors. The RJ-45 connectors enable connection to an external network. To connect a LAN cable with an RJ-45 connector, please follow the instructions below.

Step 1: Locate the RJ-45 connectors. The locations of the USB connectors are shown in **Chapter 4**.

Step 2: Align the connectors. Align the RJ-45 connector on the LAN cable with one of the RJ-45 connectors on the KINO-690S1. See **Figure 5-16**.

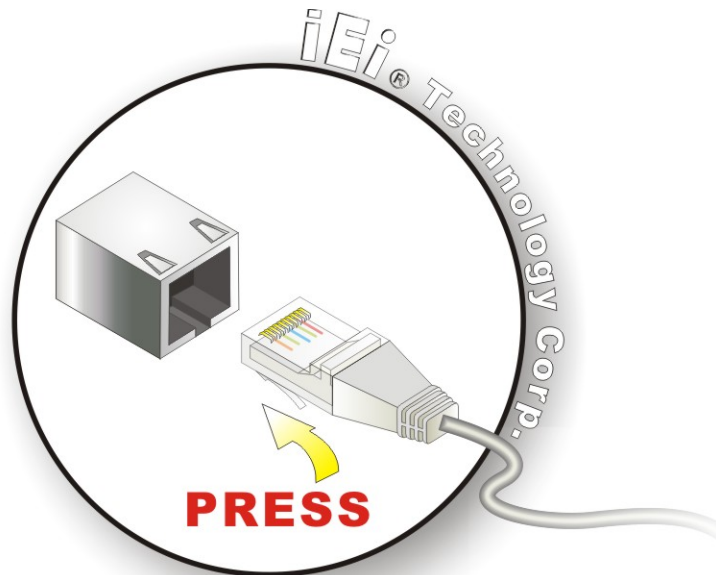

Figure 5-16: LAN Connection

Step 3: Insert the LAN cable RJ-45 connector. Once aligned, gently insert the LAN cable RJ-45 connector into the onboard RJ-45 connector.

5.8.4 PS/2 Keyboard and Mouse Connection

The KINO-690S1 has a dual PS/2 connector on the external peripheral interface panel. The dual PS/2 connector is used to connect to a keyboard and mouse to the system. Follow the steps below to connect a keyboard and mouse to the KINO-690S1.

Step 1: Locate the dual PS/2 connector. The location of the dual PS/2 connector is shown in **Chapter 3**.

Step 2: Insert the keyboard/mouse connector. Insert a PS/2 keyboard or mouse connector into the appropriate PS/2 connector on the external peripheral

KINO-690S1 Mini-ITX Motherboard

interface connector. See Figure 5-17.

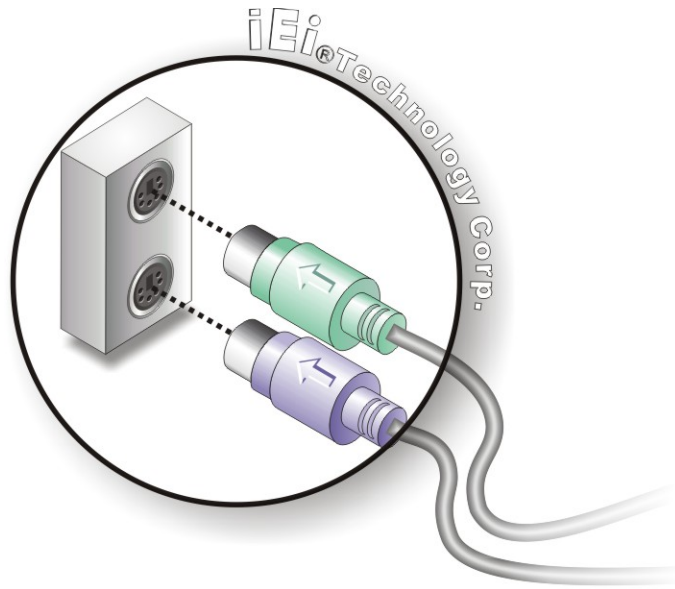

Figure 5-17: PS/2 Keyboard/Mouse Connector

5.8.5 Serial Device Connection

The KINO-690S1 has a single female DB-9 connector on the external peripheral interface panel for a serial device. Follow the steps below to connect a serial device to the KINO-690S1.

Step 1: Locate the DB-9 connector. The location of the DB-9 connector is shown in Chapter 3.

Step 2: Insert the serial connector. Insert the DB-9 connector of a serial device into the DB-9 connector on the external peripheral interface. See Figure 5-18.

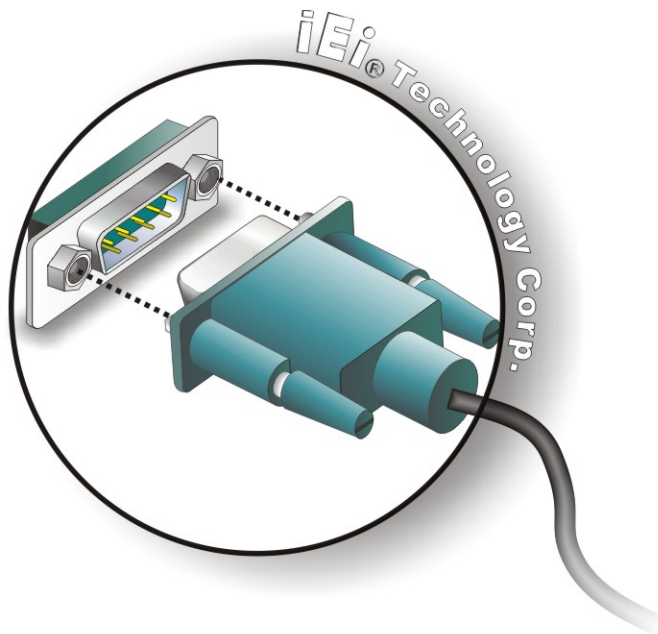

Figure 5-18: Serial Device Connector

Step 3: Secure the connector. Secure the serial device connector to the external interface by tightening the two retention screws on either side of the connector.

5.8.6 USB Connection (Dual Connector)

The external USB Series "A" receptacle connectors provide easier and quicker access to external USB devices. Follow the steps below to connect USB devices to the KINO-690S1.

Step 1: Locate the USB Series "A" receptacle connectors. The location of the USB Series "A" receptacle connectors are shown in **Chapter 3**.

Step 2: Insert a USB Series "A" plug. Insert the USB Series "A" plug of a device into the USB Series "A" receptacle on the external peripheral interface. See Figure 5-19.

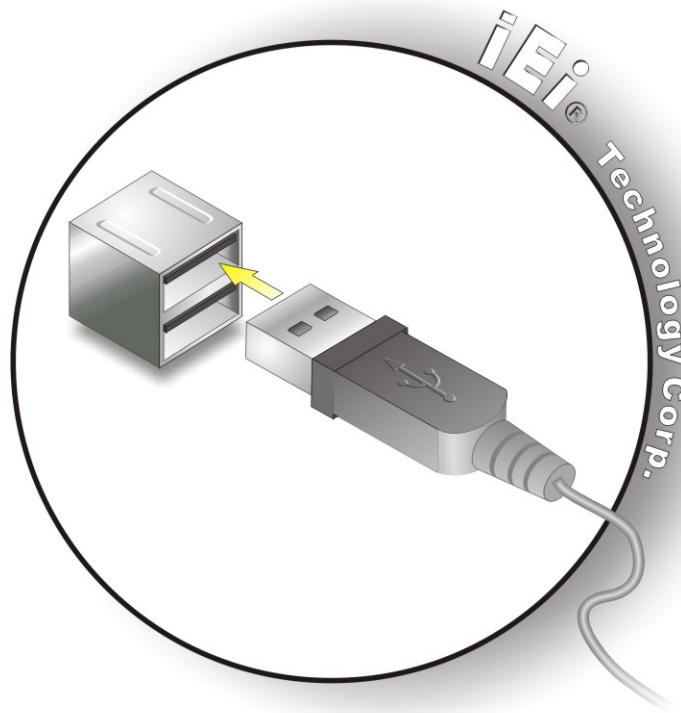

Figure 5-19: USB Connector

5.8.7 VGA Monitor Connection

The KINO-690S1 has a single female DB-15 connector on the external peripheral interface panel. The DB-15 connector is connected to a CRT or VGA monitor. To connect a monitor to the KINO-690S1, please follow the instructions below.

- Step 1:** **Locate the female DB-15 connector.** The location of the female DB-15 connector is shown in **Chapter 3**.
- Step 2:** **Align the VGA connector.** Align the male DB-15 connector on the VGA screen cable with the female DB-15 connector on the external peripheral interface.
- Step 3:** **Insert the VGA connector** Once the connectors are properly aligned with the insert the male connector from the VGA screen into the female connector on the KINO-690S1. See **Figure 5-20**.

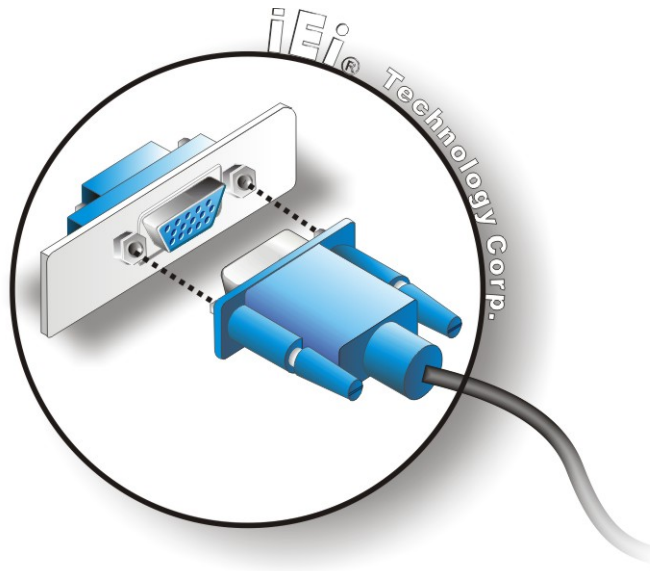

Figure 5-20: VGA Connector

Step 4: Secure the connector. Secure the DB-15 VGA connector from the VGA monitor to the external interface by tightening the two retention screws on either side of the connector.

Chapter

6

BIOS Screens

6.1 Introduction

A licensed copy of AMI BIOS is preprogrammed into the ROM BIOS. The BIOS setup program allows users to modify the basic system configuration. This chapter describes how to access the BIOS setup program and the configuration options that may be changed.

6.1.1 Starting Setup

The AMI BIOS is activated when the computer is turned on. The setup program can be activated in one of two ways.

1. Press the **DELETE** key as soon as the system is turned on or
2. Press the **DELETE** key when the “**Press Del to enter SETUP**” message appears on the screen. 0.

If the message disappears before the **DELETE** key is pressed, restart the computer and try again.

6.1.2 Using Setup

Use the arrow keys to highlight items, press **ENTER** to select, use the PageUp and PageDown keys to change entries, press **F1** for help and press **Esc** to quit. Navigation keys are shown in.

Key	Function
Up arrow	Move to previous item
Down arrow	Move to next item
Left arrow	Move to the item on the left hand side
Right arrow	Move to the item on the right hand side
Esc key	Main Menu – Quit and not save changes into CMOS Status Page Setup Menu and Option Page Setup Menu -- Exit current page and return to Main Menu
Page Up key	Increase the numeric value or make changes
Page Dn key	Decrease the numeric value or make changes

KINO-690S1 Mini-ITX Motherboard

F1 key	General help, only for Status Page Setup Menu and Option Page Setup Menu
F2 /F3 key	Change color from total 16 colors. F2 to select color forward.
F10 key	Save all the CMOS changes, only for Main Menu

Table 6-1: BIOS Navigation Keys

6.1.3 Getting Help

When **F1** is pressed a small help window describing the appropriate keys to use and the possible selections for the highlighted item appears. To exit the Help Window press **Esc** or the **F1** key again.

6.1.4 Unable to Reboot After Configuration Changes

If the computer cannot boot after changes to the system configuration is made, CMOS defaults. Use the jumper described in **Chapter 5**.

6.1.5 BIOS Menu Bar

The **menu bar** on top of the BIOS screen has the following main items:

- **Main** Changes the basic system configuration.
- **Advanced** Changes the advanced system settings.
- **PCIPnP** Changes the advanced PCI/PnP Settings
- **Boot** Changes the system boot configuration.
- **Security** Sets User and Supervisor Passwords.
- **Chipset** Changes the chipset settings.
- **Power** Changes power management settings.
- **Exit** Selects exit options and loads default settings

The following sections completely describe the configuration options found in the menu items at the top of the BIOS screen and listed above.

6.2 Main

The **Main** BIOS menu (**BIOS Menu 1**) appears when the **BIOS Setup** program is entered.

The **Main** menu gives an overview of the basic system information.

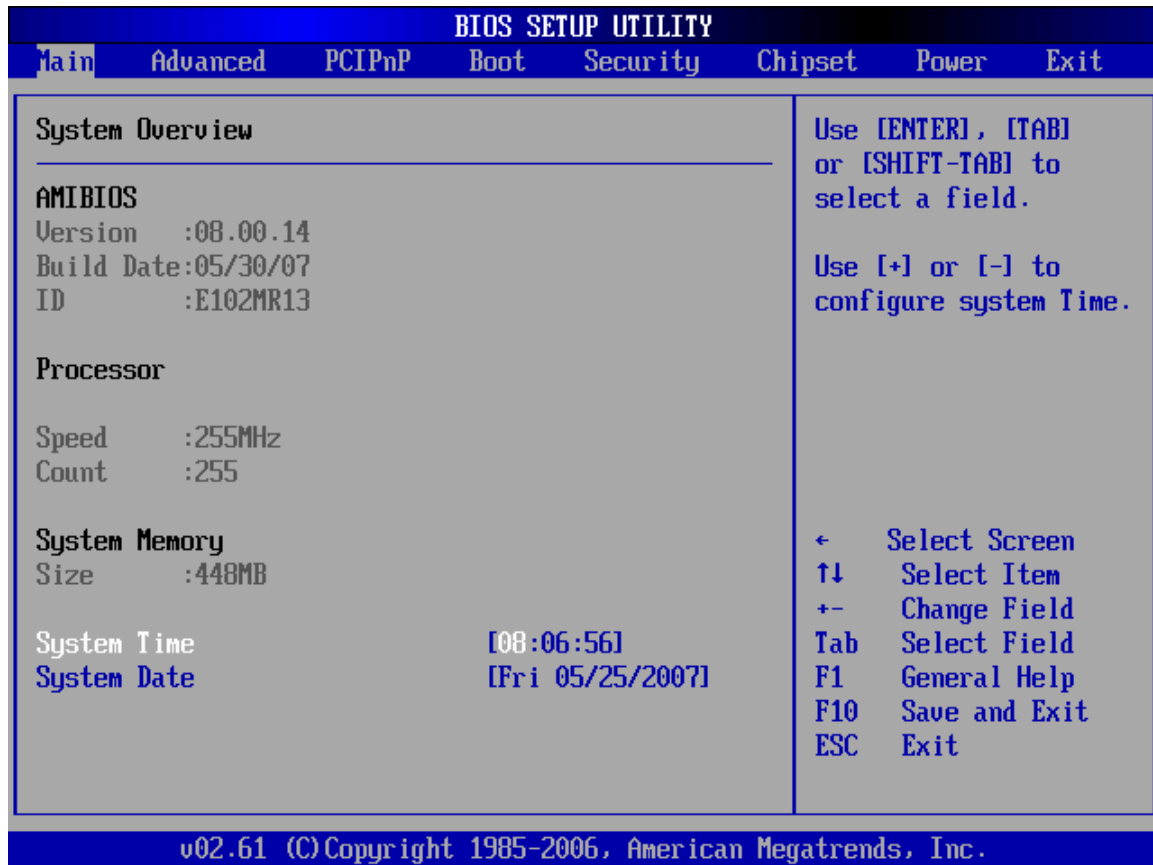

BIOS Menu 1: Main

→ System Overview

The **System Overview** lists a brief summary of different system components. The fields in **System Overview** cannot be changed. The items shown in the system overview include:

- **AMI BIOS:** Displays auto-detected BIOS information
 - **Version:** Current BIOS version
 - **Build Date:** Date the current BIOS version was made
 - **ID:** Installed BIOS ID

KINO-690S1 Mini-ITX Motherboard

- **Processor:** Displays auto-detected CPU specifications
 - **Type:** Names the currently installed processor
 - **Speed:** Lists the processor speed
 - **Count:** The number of CPUs on the motherboard
- **System Memory:** Displays the auto-detected system memory.
 - **Size:** Lists memory size

The **System Overview** field also has two user configurable fields:

→ **System Time [xx:xx:xx]**

Use the **System Time** option to set the system time. Manually enter the hours, minutes and seconds.

→ **System Date [xx/xx/xx]**

Use the **System Date** option to set the system date. Manually enter the day, month and year.

6.3 Advanced

Use the **Advanced** menu (**BIOS Menu 2**) to configure the CPU and peripheral devices through the following sub-menus:



WARNING:

Setting the wrong values in the sections below may cause the system to malfunction. Make sure that the settings made are compatible with the hardware.

- **CPU Configuration** (see **Section 6.3.1**)
- **IDE Configuration** (see **Section 6.3.2**)
- **SuperIO Configuration** (see **Section 6.3.3**)
- **Hardware Health Configuration** (see **Section 6.3.4.6.3.5**)
- **ACPI Configuration** (see **Section 6.3.5**)

- Trusted Computing (see Section 6.3.6)
- Remote Access Configuration (see Section 6.3.7)
- USB Configuration (see Section 6.3.8)



BIOS Menu 2: Advanced

6.3.1 CPU Configuration

Use the **CPU Configuration** menu (BIOS Menu 3) to view detailed CPU specifications and configure the CPU.

KINO-690S1 Mini-ITX Motherboard

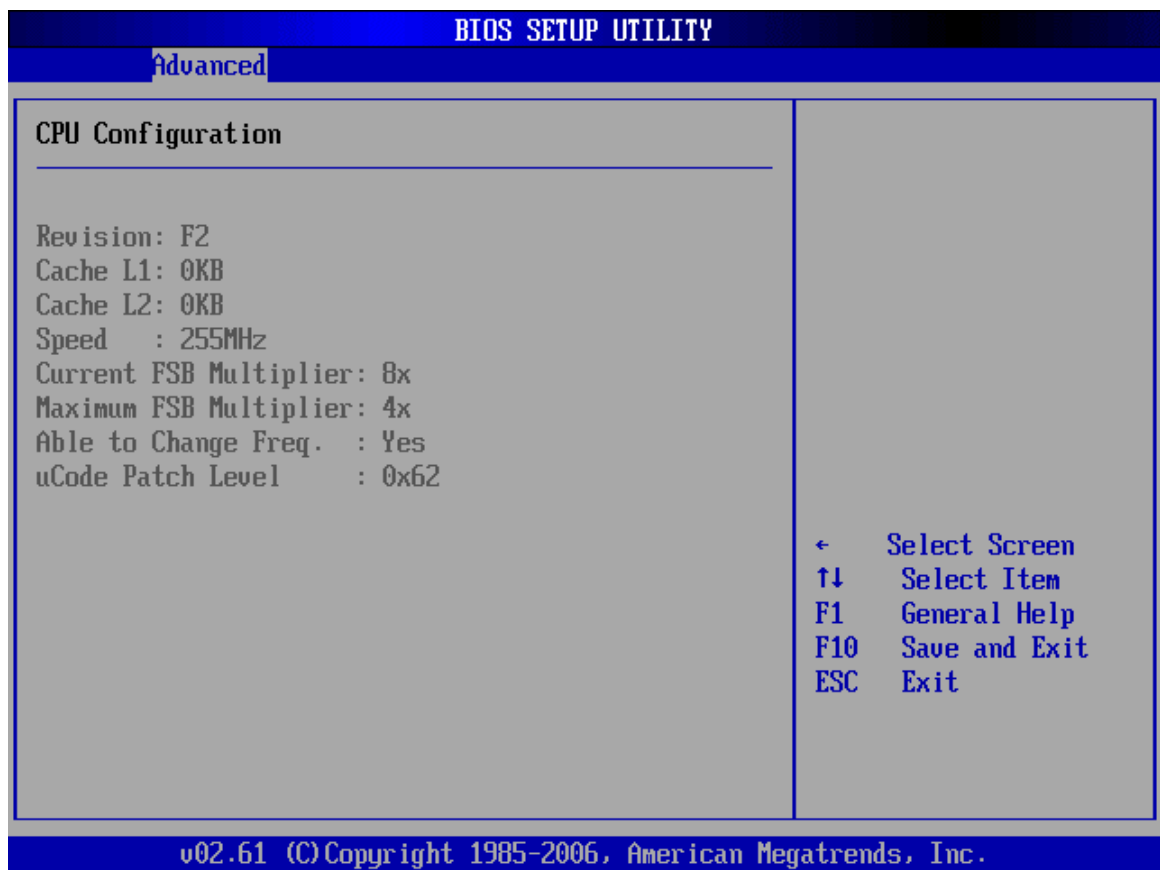
**BIOS Menu 3: CPU Configuration**

The CPU Configuration menu (BIOS Menu 3) lists the following CPU details:

- **Revision:** Lists the CPU revision number
- **Cache L1:** Lists the CPU L1 cache size
- **Cache L2:** Lists the CPU L2 cache size
- **Speed:** Lists the CPU processing speed
- **Current FSB Multiplier:** Specifies how much the FSB is increased by
- **Maximum FSB Multiplier:** Specifies the maximum the FSB can be increased
- **Able to Change Freq:** Specifies the CPU frequency cannot be changed.
- **uCode Patch Level:**

6.3.2 IDE Configuration

Use the **IDE Configuration** menu (**BIOS Menu 4**) to change and/or set the configuration of the IDE devices installed in the system.

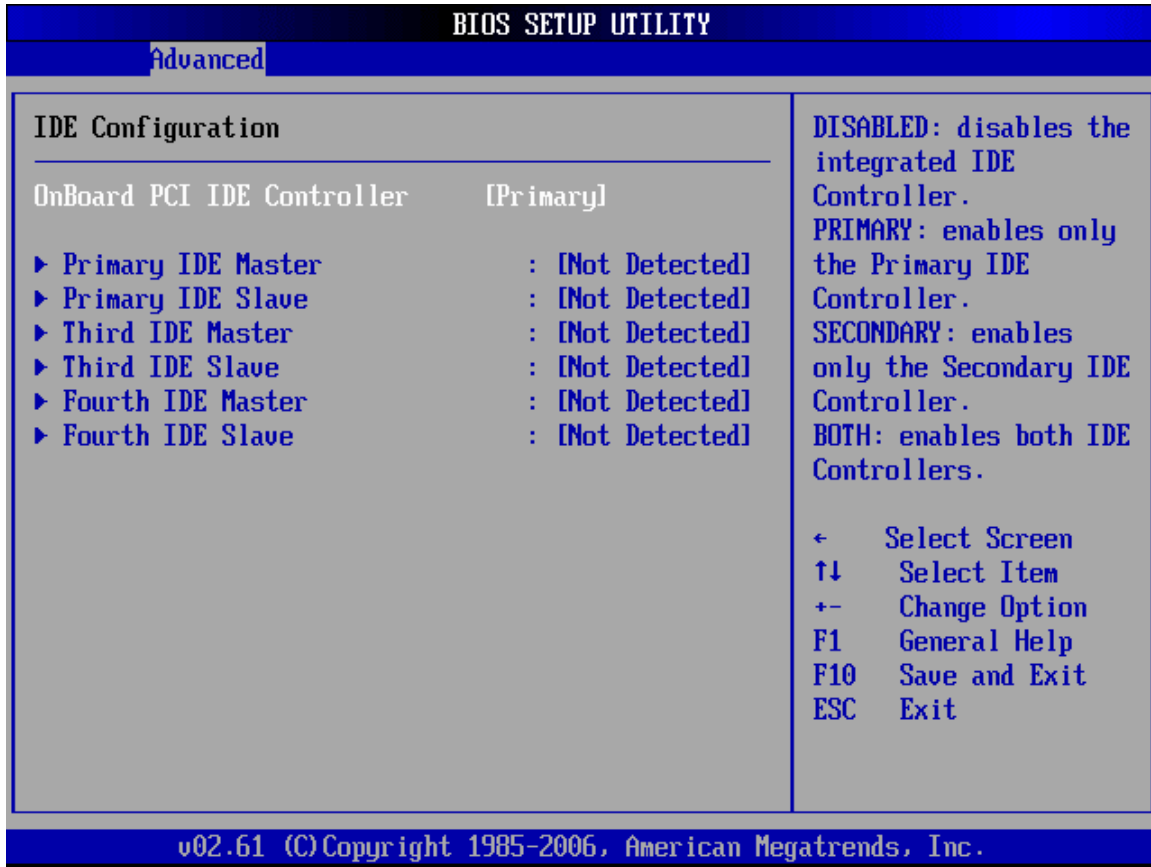

BIOS Menu 4: IDE Configuration

→ OnBoard PCI IDE Controller [Both]

The **OnBoard PCI IDE Controller** BIOS option specifies the IDE channels used by the onboard PCI IDE controller. The following configuration options are available.

- **Disabled** Prevents the system from using the onboard IDE controller
- **Primary** Only allows the system to detect the Primary IDE

KINO-690S1 Mini-ITX Motherboard

channel, including both the Primary Master and Primary Slave)

→ IDE Master and IDE Slave

When entering setup, BIOS auto detects the presence of IDE devices. BIOS displays the status of the auto detected IDE devices. The following IDE devices are detected and are shown in the **IDE Configuration** menu:

- Primary IDE Master
- Primary IDE Slave
- Secondary IDE Master
- Secondary IDE Slave

The **IDE Configuration** menu (**BIOS Menu 4**) allows changes to the configurations for the IDE devices installed in the system. If an IDE device is detected, and one of the above listed four BIOS configuration options are selected, the IDE configuration options shown in **Section 6.3.2.1** appear.

6.3.2.1 IDE Master, IDE Slave

Use the **IDE Master** and **IDE Slave** configuration menu to view both primary and secondary IDE device details and configure the IDE devices connected to the system.

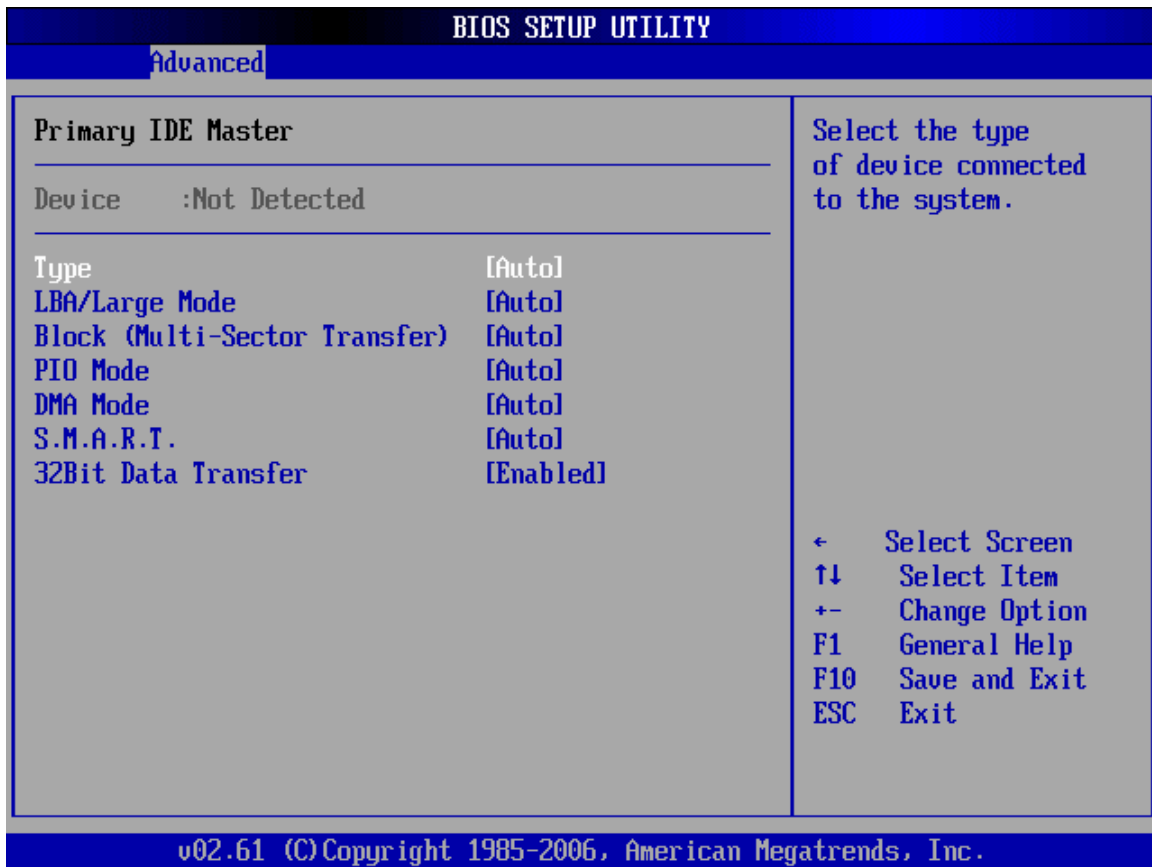

BIOS Menu 5: IDE Master and IDE Slave Configuration

→ Auto-Detected Drive Parameters

The “grayed-out” items in the left frame are IDE disk drive parameters automatically detected from the firmware of the selected IDE disk drive. The drive parameters are listed as follows:

- **Device:** Lists the device type (e.g. hard disk, CD-ROM etc.)
- **Type:** Indicates the type of devices a user can manually select
- **Vendor:** Lists the device manufacturer
- **Size:** List the storage capacity of the device.
- **LBA Mode:** Indicates whether the LBA (Logical Block Addressing) is a method of addressing data on a disk drive is supported or not.
- **Block Mode:** Block mode boosts IDE drive performance by increasing the amount of data transferred. Only 512 bytes of data can be transferred per

KINO-690S1 Mini-ITX Motherboard

interrupt if block mode is not used. Block mode allows transfers of up to 64 KB per interrupt.

- **PIO Mode:** Indicates the PIO mode of the installed device.
- **Async DMA:** Indicates the highest Asynchronous DMA Mode that is supported.
- **Ultra DMA:** Indicates the highest Synchronous DMA Mode that is supported.
- **S.M.A.R.T.:** Indicates whether or not the Self-Monitoring Analysis and Reporting Technology protocol is supported.
- **32Bit Data Transfer:** Enables 32-bit data transfer.

→ Type [Auto]

Use the **Type** BIOS option select the type of device the AMIBIOS attempts to boot from after the Power-On Self-Test (POST) is complete.

→ **Not Installed** BIOS is prevented from searching for an IDE disk drive on the specified channel.

→ **Auto** **DEFAULT** The BIOS auto detects the IDE disk drive type attached to the specified channel. This setting should be used if an IDE hard disk drive is attached to the specified channel.

→ **CD/DVD** The CD/DVD option specifies that an IDE CD-ROM drive is attached to the specified IDE channel. The BIOS does not attempt to search for other types of IDE disk drives on the specified channel.

→ **ARMD** This option specifies an ATAPI Removable Media Device. These include, but are not limited to:

→ **ZIP**

→ **LS-120**

→

→ **LBA/Large Mode [Auto]**

Use the **LBA/Large Mode** option to disable or enable BIOS to auto detects LBA (Logical Block Addressing). LBA is a method of addressing data on a disk drive. In LBA mode, the maximum drive capacity is 137 GB.

→ **Disabled** BIOS is prevented from using the LBA mode control on the specified channel.

→ **Auto** **DEFAULT** BIOS auto detects the LBA mode control on the specified channel.

→ **Block (Multi Sector Transfer) [Auto]**

Use the **Block (Multi Sector Transfer)** to disable or enable BIOS to auto detect if the device supports multi-sector transfers.

→ **Disabled** BIOS is prevented from using Multi-Sector Transfer on the specified channel. The data to and from the device occurs one sector at a time.

→ **Auto** **DEFAULT** BIOS auto detects Multi-Sector Transfer support on the drive on the specified channel. If supported the data transfer to and from the device occurs multiple sectors at a time.

→ **PIO Mode [Auto]**

Use the **PIO Mode** option to select the IDE PIO (Programmable I/O) mode program timing cycles between the IDE drive and the programmable IDE controller. As the PIO mode increases, the cycle time decreases.

→ **Auto** **DEFAULT** BIOS auto detects the PIO mode. Use this value if the IDE disk drive support cannot be determined.

KINO-690S1 Mini-ITX Motherboard

- 0 PIO mode 0 selected with a maximum transfer rate of 3.3MBps
- 1 PIO mode 1 selected with a maximum transfer rate of 5.2MBps
- 2 PIO mode 2 selected with a maximum transfer rate of 8.3MBps
- 3 PIO mode 3 selected with a maximum transfer rate of 11.1MBps
- 4 PIO mode 4 selected with a maximum transfer rate of 16.6MBps
(This setting generally works with all hard disk drives manufactured after 1999. For other disk drives, such as IDE CD-ROM drives, check the specifications of the drive.)

→ DMA Mode [Auto]

Use the **DMA Mode** BIOS selection to adjust the DMA mode options.

- **Auto** **DEFAULT** BIOS auto detects the DMA mode. Use this value if the IDE disk drive support cannot be determined.
- **SWDMA0** Single Word DMA mode 0 selected with a maximum data transfer rate of 2.1MBps
- **SWDMA1** Single Word DMA mode 1 selected with a maximum data transfer rate of 4.2MBps
- **SWDMA2** Single Word DMA mode 2 selected with a maximum data transfer rate of 8.3MBps
- **MWDMA0** Multi Word DMA mode 0 selected with a maximum data transfer rate of 4.2MBps
- **MWDMA1** Multi Word DMA mode 1 selected with a maximum data transfer rate of 13.3MBps
- **MWDMA2** Multi Word DMA mode 2 selected with a maximum data transfer rate of 16.6MBps

- **UDMA1** Ultra DMA mode 0 selected with a maximum data transfer rate of 16.6MBps
- **UDMA1** Ultra DMA mode 1 selected with a maximum data transfer rate of 25MBps
- **UDMA2** Ultra DMA mode 2 selected with a maximum data transfer rate of 33.3MBps
- **UDMA3** Ultra DMA mode 3 selected with a maximum data transfer rate of 44MBps (To use this mode, it is required that an 80-conductor ATA cable is used.)
- **UDMA4** Ultra DMA mode 4 selected with a maximum data transfer rate of 66.6MBps (To use this mode, it is required that an 80-conductor ATA cable is used.)
- **UDMA5** Ultra DMA mode 5 selected with a maximum data transfer rate of 99.9MBps (To use this mode, it is required that an 80-conductor ATA cable is used.)

→ **S.M.A.R.T [Auto]**

Use the **S.M.A.R.T** option to auto-detect, disable or enable Self-Monitoring Analysis and Reporting Technology (SMART) on the drive on the specified channel. **S.M.A.R.T** predicts impending drive failures. The **S.M.A.R.T** BIOS option enables or disables this function.

- **Auto** **DEFAULT** BIOS auto detects HDD SMART support.
- **Disabled** Prevents BIOS from using the HDD SMART feature.
- **Enabled** Allows BIOS to use the HDD SMART feature

→ **32Bit Data Transfer [Enabled]**

Use the **32Bit Data Transfer** BIOS option to enables or disable 32-bit data transfers.

KINO-690S1 Mini-ITX Motherboard

- ➔ **Disabled** Prevents the BIOS from using 32-bit data transfers.
- ➔ **Enabled** **DEFAULT** Allows BIOS to use 32-bit data transfers on supported hard disk drives.

6.3.3 Super IO Configuration

Use the **Super IO Configuration** menu (**BIOS Menu 6**) to set or change the configurations for the FDD controllers, parallel ports and serial ports.



BIOS Menu 6: Super IO Configuration

- ➔ **Serial Port1 Address [3F8/IRQ4]**

Use the **Serial Port1 Address** option to select the Serial Port 1 base address.

- ➔ **Disabled** No base address is assigned to Serial Port 1

- **3F8/IRQ4** **DEFAULT** Serial Port 1 I/O port address is 3F8 and the interrupt address is IRQ4
- **3E8/IRQ4** Serial Port 1 I/O port address is 3E8 and the interrupt address is IRQ4
- **2E8/IRQ3** Serial Port 1 I/O port address is 2E8 and the interrupt address is IRQ3

→ **Serial Port1 Mode [Normal]**

Use the **Serial Port1 Mode** option to select the transmitting and receiving mode for the first serial port.

- **Normal** (Default) Serial Port 1 mode is normal
- **IrDA** Serial Port 1 mode is IrDA
- **ASK IR** Serial Port 1 mode is ASK IR

→ **Serial Port2 Address [2F8/IRQ3]**

Use the **Serial Port2 Address** option to select the Serial Port 2 base address.

- **Disabled** No base address is assigned to Serial Port 2
- **2F8/IRQ3** **DEFAULT** Serial Port 2 I/O port address is 3F8 and the interrupt address is IRQ3
- **3E8/IRQ4** Serial Port 2 I/O port address is 3E8 and the interrupt address is IRQ4
- **2E8/IRQ3** Serial Port 2 I/O port address is 2E8 and the interrupt address is IRQ3

→ **Serial Port2 Mode [Normal]**

Use the **Serial Port2 Mode** option to select the Serial Port2 operational mode.

KINO-690S1 Mini-ITX Motherboard

- **Normal** **DEFAULT** Serial Port 2 mode is normal
- **IrDA** Serial Port 2 mode is IrDA
- **ASK IR** Serial Port 2 mode is ASK IR

→ **Serial Port3 Address [3E8]**

Use the **Serial Port3 Address** option to select the base addresses for serial port 3

- **Disabled** No base address is assigned to serial port 3
- **3E8** **DEFAULT** Serial port 3 I/O port address is 3E8
- **2E8** Serial port 3 I/O port address is 2E8
- **338** Serial port 3 I/O port address is 338
- **238** Serial port 3 I/O port address is 238

→ **Serial Port3 IRQ [11]**

Use the **Serial Port3 IRQ** option to select the interrupt address for serial port 3.

- **5** Serial port 3 IRQ address is 5
- **11** **DEFAULT** Serial port 3 IRQ address is 11

→ **Serial Port4 Address [2E8]**

Use the **Serial Port4 IRQ** option to select the interrupt address for serial port 4.

- **Disabled** No base address is assigned to serial port 3
- **3E8** Serial port 4 I/O port address is 3E8
- **2E8** **DEFAULT** Serial port 4 I/O port address is 2E8
- **338** Serial port 3 I/O port address is 338

→ 238 Serial port 3 I/O port address is 238

→ **Serial Port4 IRQ [10]**

Use the **Serial Port4 IRQ** option to select the interrupt address for serial port 4.

→ 15 **DEFAULT** Serial port 4 IRQ address is 5

→ 11 Serial port 4 IRQ address is 11

6.3.4 Hardware Health Configuration

The **Hardware Health Configuration** menu (**BIOS Menu 7**) shows the operating temperature, fan speeds and system voltages.

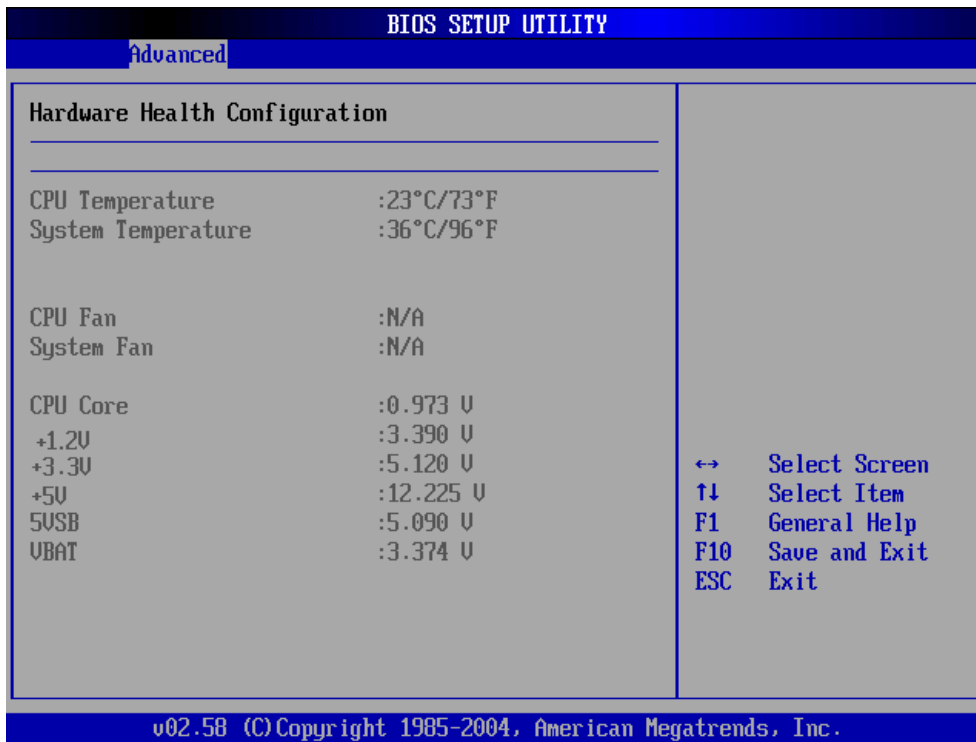

BIOS Menu 7: Hardware Health Configuration

The following system parameters and values are shown. The system parameters that are monitored are:

KINO-690S1 Mini-ITX Motherboard

- **System Temperatures:** The following system temperatures are monitored
 - CPU Temperature
 - System Temperature
- **Fan Speeds:** The CPU cooling fan speed is monitored.
 - CPU Fan Speed
 - System Fan Speed
- **Voltages:** The following system voltages are monitored
 - CPU Core
 - +1.20V
 - +3.30V
 - +5.0V
 - 5VSB
 - VBAT

6.3.5 ACPI Configuration

The **ACPI Configuration** menu (**BIOS Menu 8**) configures the Advanced Configuration and Power Interface (ACPI) and Power Management (APM) options.

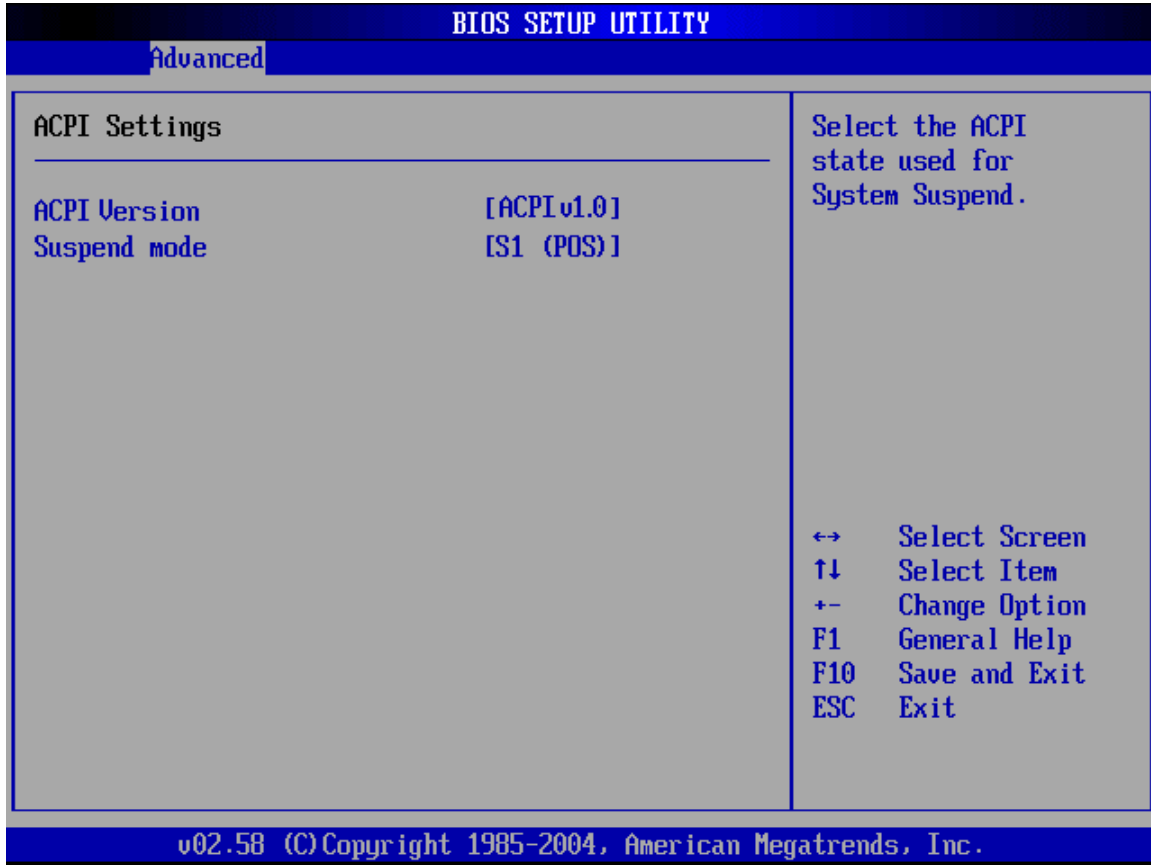

BIOS Menu 8: ACPI Configuration

→ ACPI Version Features [ACPI v1.0]

Use the ACPI Version Features option to select the ACPI (Advanced Configuration and Power Interface Specification) version to run on the system.

- **ACPI v1.0** (Default) ACPI revision 1.0 runs on the system
- **ACPI v2.0** ACPI revision 1.0 runs on the system
- **ACPI v3.0** ACPI revision 1.0 runs on the system

→ Suspend Mode [S1(POS)]

The **Suspend Mode** BIOS option specifies the sleep state your system will enter when it is not being used.

KINO-690S1 Mini-ITX Motherboard

- ➔ **S1 (POS)** (Default) System appears off. The CPU is stopped; RAM is refreshed; the system is running in a low power mode.
- ➔ **S3 (STR)** System appears off. The CPU has no power; RAM is in slow refresh; the power supply is in a reduced power mode.
- ➔ **Auto** The system automatically determines the system sleep state.

6.3.6 Trusted Computing

Use the **Trusted Computing** menu (**BIOS Menu 9**) to configure settings related to the Trusted Computing Group (TCG) Trusted Platform Module (TPM).

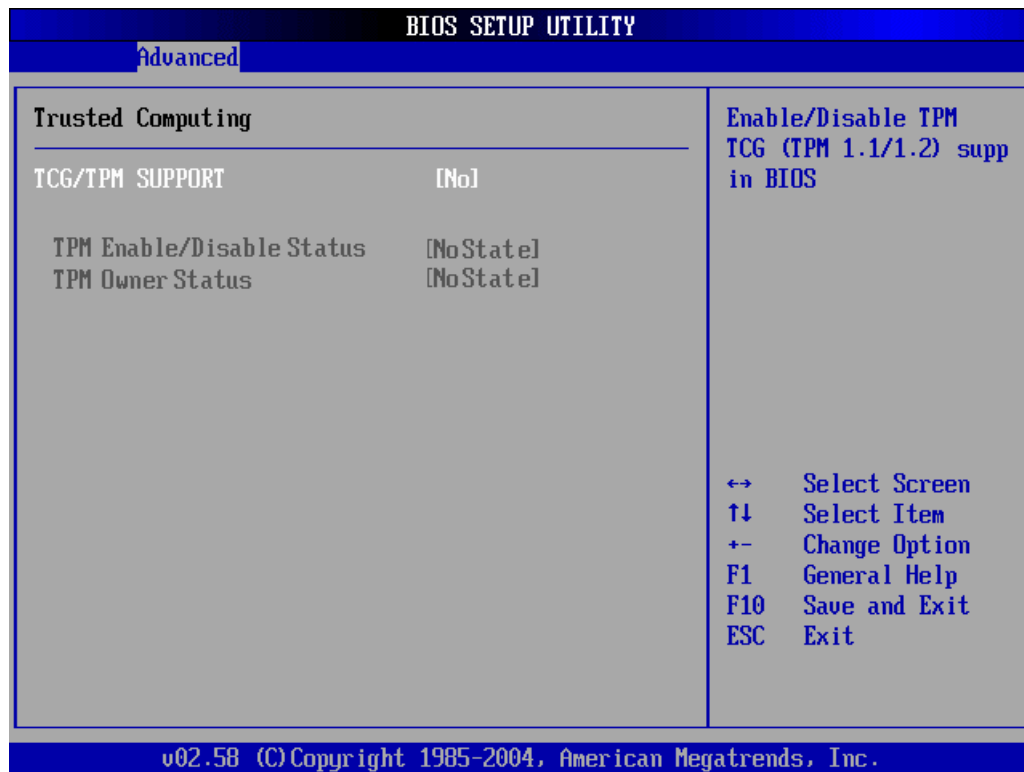

BIOS Menu 9: Trusted Computing

→ **TCG/TPM Support [Yes]**

Use the **TCG/TPM Support** option to configure support for the TPM.

→ **No** **DEFAULT** TPM support is disabled.

→ **Yes** TPM support is enabled.

→ **TPM Enable/Disable Status [No State]**

Use the **TPM Enable/Disable Status** to see if the TPM module has been enabled or disabled.

→ **TPM Owner Status [No State]**

Use the **TPM Owner Status** to see if the owner status of the TPM module.

6.3.7 Remote Access Configuration

Use the **Remote Access Configuration** menu (**BIOS Menu 10**) to configure remote access parameters. The **Remote Access Configuration** is an AMIBIOS feature and allows a remote host running a terminal program to display and configure the BIOS settings.

KINO-690S1 Mini-ITX Motherboard

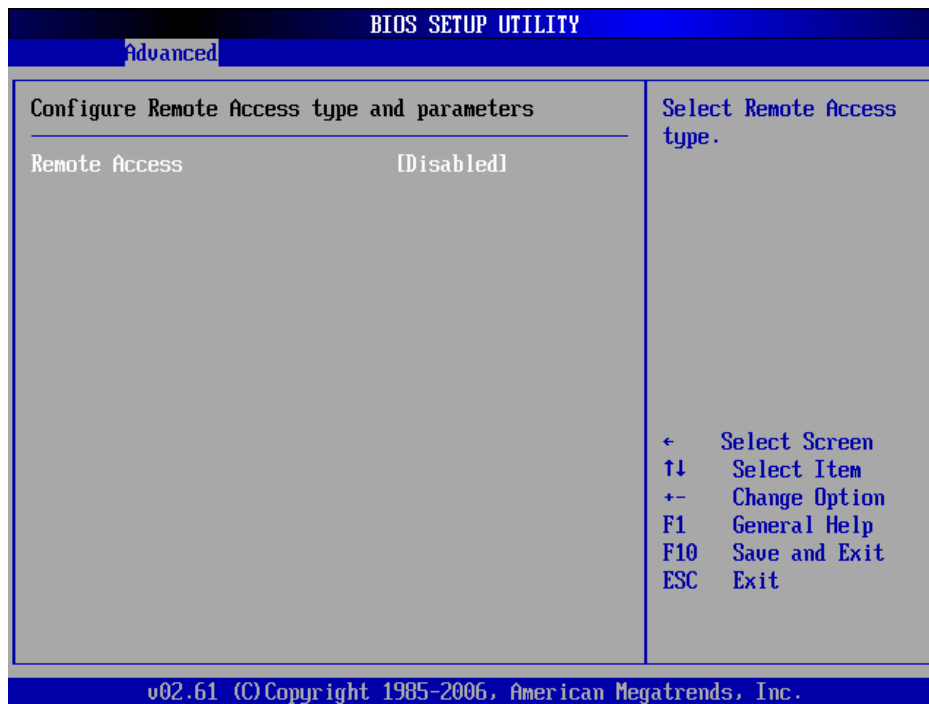

BIOS Menu 10: Remote Access Configuration [Advanced]

→ Remote Access [Disabled]

Use the **Remote Access** option to enable or disable access to the remote functionalities of the system.

→ **Disabled** **DEFAULT** Remote access is disabled.

→ **Enabled** Remote access configuration options shown below appear:

→ **Serial Port Number**

→ **Serial Port Mode**

→ **Flow Control**

→ **Redirection after BIOS POST**

→ **Terminal Type**

→ VT-UTF8 Combo Key Support

→ Sredir Memory Display Delay

These configuration options are discussed below.

→ **Serial Port Number [COM1]**

Use the **Serial Port Number** option allows to select the serial port used for remote access.

→ **COM1** **DEFAULT** System is remotely accessed through COM1

→ **COM2** System is remotely accessed through COM2

NOTE: Make sure the selected COM port is enabled through the Super I/O configuration menu.

→ **Base Address, IRQ [3F8h,4]**

The **Base Address, IRQ** option cannot be configured and only shows the interrupt address of the serial port listed above.

→ **Serial Port Mode [115200 8,n,1]**

Use the **Serial Port Mode** option to select baud rate through which the console redirection is made. The following configuration options are available

- 115200 8,n,1 **DEFAULT**
- 57600 8,n,1
- 38400 8,n,1
- 19200 8,n,1
- 09600 8,n,1

KINO-690S1 Mini-ITX Motherboard



NOTE:

Identical baud rate setting must be set on the host (a management computer running a terminal software) and the slave

→ Flow Control [None]

Use the **Flow Control** option to report the flow control method for the console redirection application.

- **None** **DEFAULT** No control flow,
- **Hardware** Hardware is set as the console redirection
- **Software** Software is set as the console redirection

→ Redirection After BIOS POST [Always]

Use the **Redirection After BIOS POST** option to specify when console redirection should occur.

- **Disabled** The console is not redirected after POST
- **Boot Loader** Redirection is active during POST and during Boot Loader
- **Always** **DEFAULT** Redirection is always active (Some Oses may not work if set to Always)

→ Terminal Type [ANSI]

Use the **Terminal Type** BIOS option to specify the remote terminal type.

- **ANSI** **DEFAULT** The target terminal type is ANSI
- **VT100** The target terminal type is VT100

KINO-690S1 Mini-ITX Motherboard

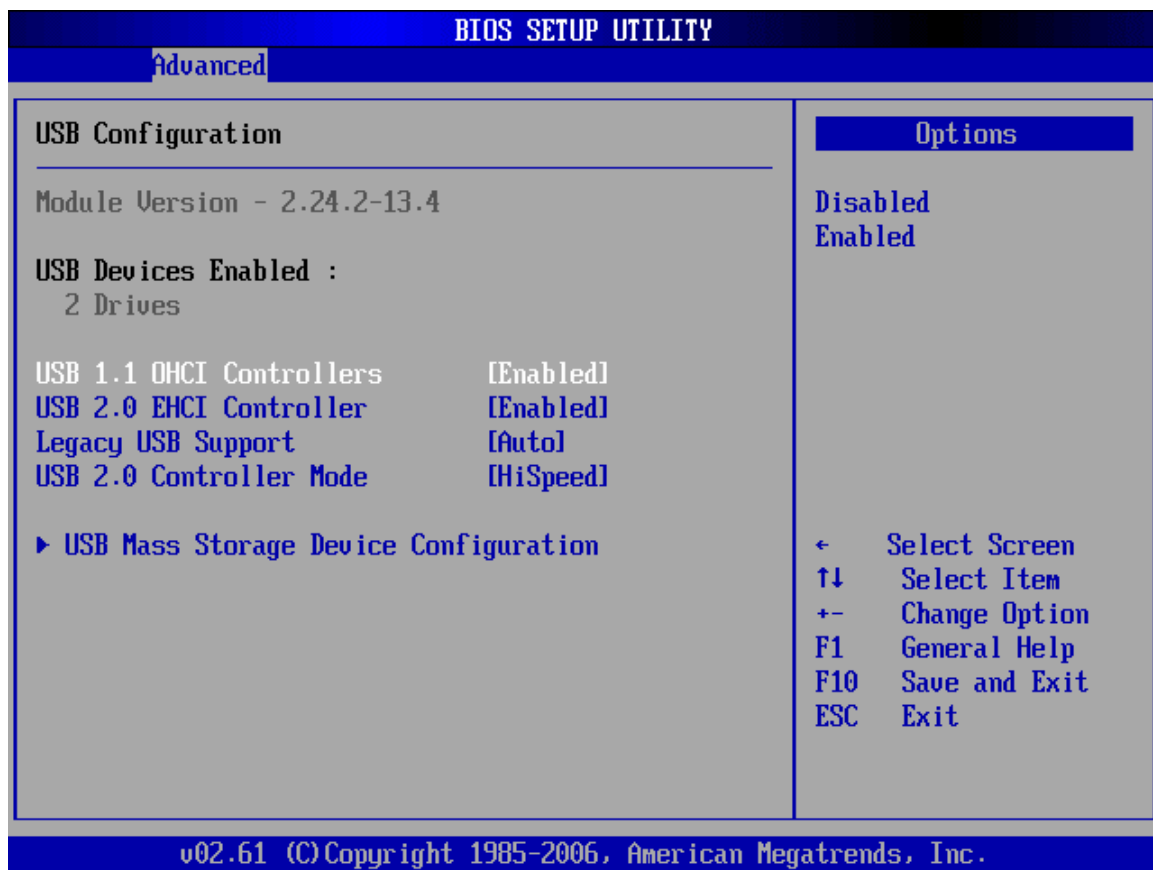

BIOS Menu 11: USB Configuration

→ USB 1.1 EHCI Controller [Enabled]

The **USB 1.1 OHCI Controller** BIOS option enables or disables the USB 1.1 controller

- **Disabled** USB 1.1 function disabled
- **Enabled** (Default) USB 1.1 function enabled

→ USB 2.0 EHCI Controller [Enabled]

The **USB 2.0 EHCI Controller** BIOS option enables or disables the USB 2.0 controller

- **Disabled** USB EHCI function disabled
- **Enabled** (Default) USB function enabled

➔ **Legacy USB Support [Enabled]**

Use the **Legacy USB Support** BIOS option to enable USB mouse and USB keyboard support.

Normally if this option is not enabled, any attached USB mouse or USB keyboard does not become available until a USB compatible operating system is fully booted with all USB drivers loaded. When this option is enabled, any attached USB mouse or USB keyboard can control the system even when there is no USB driver loaded onto the system.

- ➔ **Disabled** Legacy USB support disabled
- ➔ **Enabled** **DEFAULT** Legacy USB support enabled
- ➔ **Auto** Legacy USB support disabled if no USB devices are connected

➔ **USB2.0 Controller Mode [HiSpeed]**

Use the **USB2.0 Controller Mode** option to set the speed of the USB2.0 controller.

- ➔ **FullSpeed** The controller is capable of operating at 12Mb/s
- ➔ **HiSpeed** **DEFAULT** The controller is capable of operating at 480Mb/s

6.3.8.1 USB Mass Storage Device Configuration



NOTE:

This option is only available if a USB drive is inserted into the USB port.

Use the USB Mass Storage Device Configuration menu (BIOS Menu 12) to configure USB mass storage class devices.

KINO-690S1 Mini-ITX Motherboard

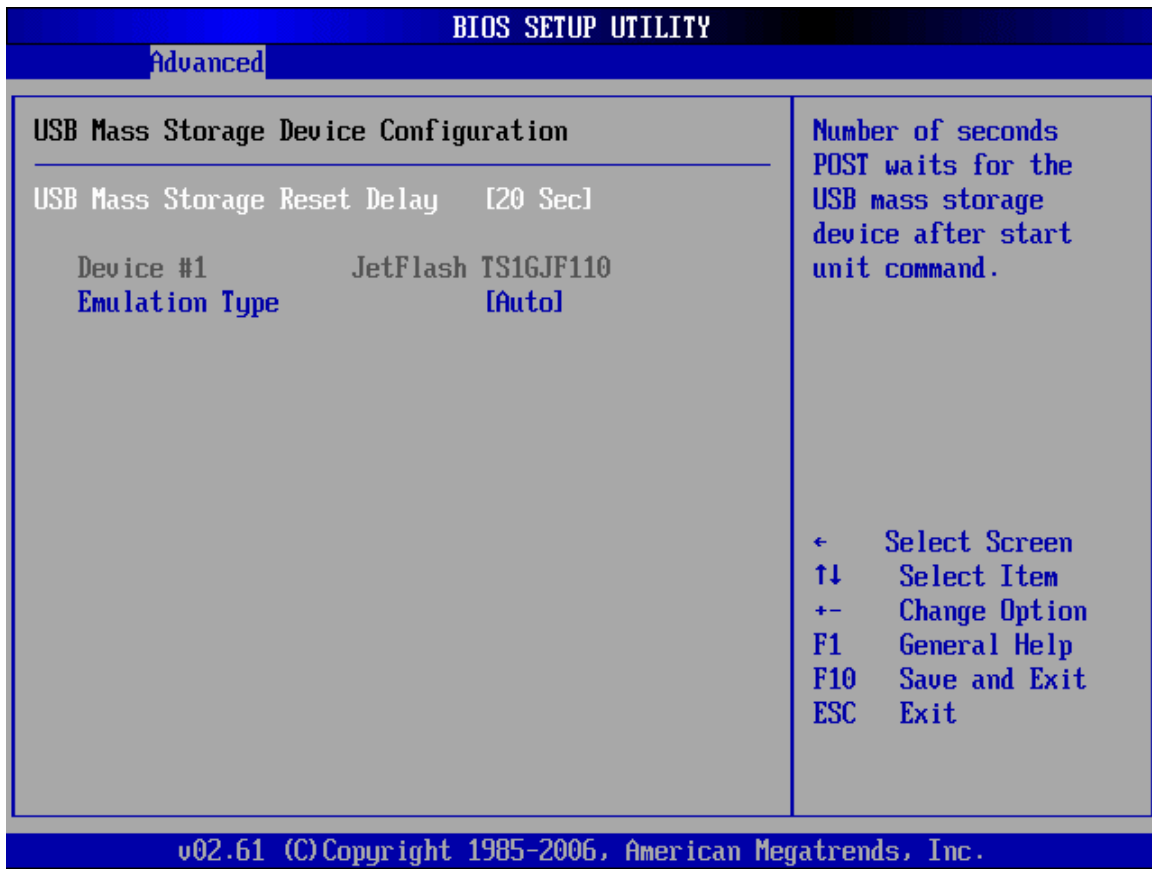

BIOS Menu 12: USB Mass Storage Device Configuration

→ USB Mass Storage Reset Delay [20 Sec]

Use the **USB Mass Storage Reset Delay** option to set the number of seconds POST waits for the USB mass storage device after the start unit command.

- **10 Sec** POST waits 10 seconds for the USB mass storage device after the start unit command.
- **20 Sec** **DEFAULT** POST waits 20 seconds for the USB mass storage device after the start unit command.
- **30 Sec** POST waits 30 seconds for the USB mass storage device after the start unit command.

→ **40 Sec** POST waits 40 seconds for the USB mass storage device after the start unit command.

→ **Device ##**

The **Device##** field lists the USB devices that are connected to the system.

→ **Emulation Type [Auto]**

Use the **Emulation Type** BIOS option to specify the type of emulation BIOS has to provide for the USB device.



NOTE:

Please note that the device's formatted type and the emulation type provided by the BIOS must match for a device to boot properly. If both types do not match then device's behavior is undefined. To make sure both types match, format the device using BIOS INT13h calls after selecting the proper emulation option in BIOS setup. The FORMAT utility provided by Microsoft® MS-DOS®, Microsoft® Windows® 95, and Microsoft® Windows® 98 can be used for this purpose.

→ **Auto** **DEFAULT** BIOS auto-detects the current USB.

→ **Floppy** The USB device will be emulated as a floppy drive. The device can be either A: or B: responding to INT13h calls that return DL = 0 or DL = 1 respectively.

→ **Forced FDD** Allows a hard disk image to be connected as a floppy image. This option works only for drives formatted with FAT12, FAT16 or FAT32.

KINO-690S1 Mini-ITX Motherboard

- ➔ **Hard Disk** Allows the USB device to be emulated as hard disk responding to INT13h calls that return DL values of 80h or above.

- ➔ **CDROM** Assumes the CD-ROM is formatted as bootable media. All the devices that support block sizes greater than 512 bytes can only be booted using this option.

6.4 PCI/PnP

Use the PCI/PnP menu (BIOS Menu 13) to configure advanced PCI and PnP settings.



WARNING:

Setting wrong values for the BIOS selections in the PCIPnP BIOS menu may cause the system to malfunction.

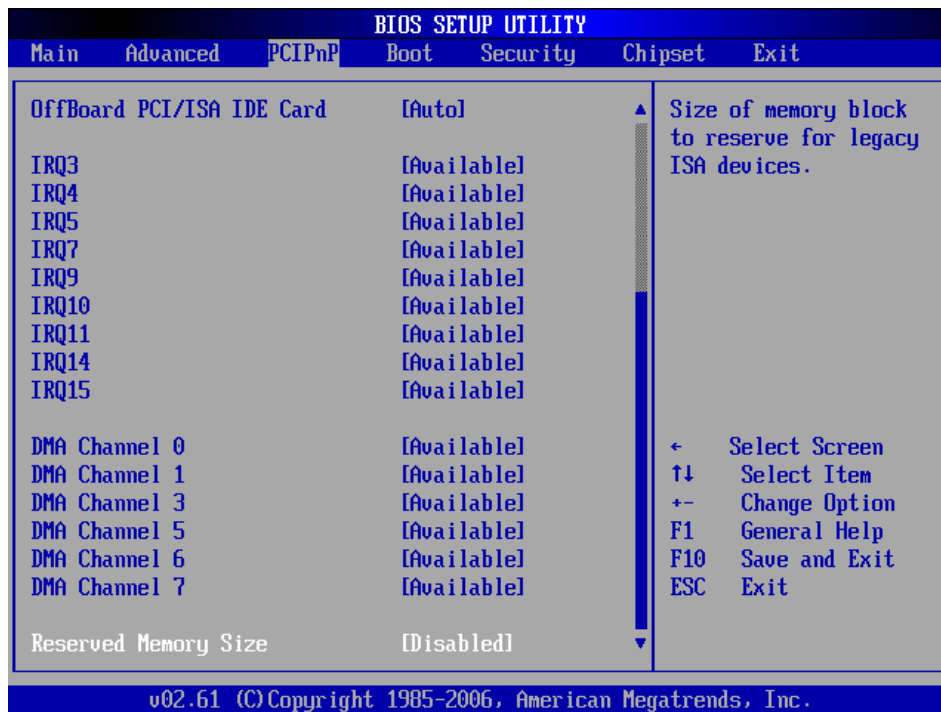
BIOS Menu 13: PCI/PnP Configuration

KINO-690S1 Mini-ITX Motherboard

→ Clear NVRAM [No]

Use the **Clear NVRAM** option to specify if the NVRAM (Non-Volatile RAM) is cleared when the power is turned off.

- **No** **DEFAULT** System does not clear NVRAM during system boot
- **Yes** System clears NVRAM during system boot

→ Plug & Play O/S [No]

Use the **Plug & Play O/S** BIOS option to specify whether system plug and play devices are configured by the operating system or the BIOS.

- **No** **DEFAULT** If the operating system does not meet the Plug and Play specifications, this option allows the BIOS to configure all the devices in the system.
- **Yes** This setting allows the operating system to change the interrupt, I/O, and DMA settings. Set this option if the system is running Plug and Play aware operating systems.

→ PCI Latency Timer [64]

Use the **PCI Latency Timer** option to specify the PCI latency time. The latency time is measured in units of PCI clock cycles for the PCI device latency timer register.

Configuration options are:

- 32
- 64 Default
- 96
- 128
- 160
- 192
- 224
- 248

→ Allocate IRQ to PCI VGA [Yes]

Use the **Allocate IRQ to PCI VGA** option to restrict the system from giving the VGA adapter card an interrupt address.

- **Yes** (Default) Assigns an IRQ to a PCI VGA card if card requests IRQ
- **No** Does not assign IRQ to a PCI VGA card even if the card requests an IRQ

→ Palette Snooping [Disabled]

Use the **Palette Snooping** option to enable or disable the palette snooping function.

- **Disabled** DEFAULT Unless the VGA card manufacturer requires palette snooping to be enabled, this option should be disabled.
- **No/Enab led** PCI devices are informed that an ISA based Graphics device is installed in the system so the ISA based Graphics card functions correctly. This does not necessarily indicate a physical ISA adapter card. The graphics chipset can be mounted on a PCI card. Always check with the adapter card manual first, before modifying the default settings in the BIOS.

→ PCI IDE BusMaster [Disabled]

Use the **PCI IDE BusMaster** BIOS option to enable or prevent PCI IDE busmastering.

- **Disabled** DEFAULT Busmastering is prevented
- **No/Enab led** IDE controller on the PCI local bus has mastering capabilities

→ OffBoard PCI/ISA IDE Card [Auto]

KINO-690S1 Mini-ITX Motherboard

Use the OffBoard PCI/ISA IDE Card BIOS option to select the OffBoard PCI/ISA IDE Card.

- **Auto** **DEFAULT** The location of the Off Board PCI IDE adapter card is automatically detected by the AMIBIOS.
 - **PCI Slot 1** PCI Slot 1 is selected as the location of the OffBoard PCI IDE adapter card. Only select this slot if the adapter card is installed in PCI Slot 1.
 - **PCI Slot 2** PCI Slot 2 is selected as the location of the OffBoard PCI IDE adapter card. Only select this slot if the adapter card is installed in PCI Slot 2.
 - **PCI Slot 3** PCI Slot 3 is selected as the location of the OffBoard PCI IDE adapter card. Only select this slot if the adapter card is installed in PCI Slot 3.
 - **PCI Slot 4** PCI Slot 4 is selected as the location of the OffBoard PCI IDE adapter card. Only select this slot if the adapter card is installed in PCI Slot 4.
 - **PCI Slot 5** PCI Slot 5 is selected as the location of the OffBoard PCI IDE adapter card. Only select this slot if the adapter card is installed in PCI Slot 5.
 - **PCI Slot 6** PCI Slot 6 is selected as the location of the OffBoard PCI IDE adapter card. Only select this slot if the adapter card is installed in PCI Slot 6.
- **IRQ# [Available]**

Use the **IRQ#** address to specify what IRQs can be assigned to a particular peripheral device.

- ➔ **Available** **DEFAULT** The specified IRQ is available to be used by PCI/PnP devices

- ➔ **Reserved** The specified IRQ is reserved for use by Legacy ISA devices

Available IRQ addresses are:

- IRQ3
- IRQ4
- IRQ5
- IRQ7
- IRQ9
- IRQ10
- IRQ 11
- IRQ 14
- IRQ 15

➔ **DMA Channel# [Available]**

Use the **DMA Channel#** option to assign a specific DMA channel to a particular PCI/PnP device.

- ➔ **Available** **DEFAULT** The specified DMA is available to be used by PCI/PnP devices

- ➔ **Reserved** The specified DMA is reserved for use by Legacy ISA devices

Available DMA Channels are:

- DM Channel 0
- DM Channel 1
- DM Channel 3
- DM Channel 5
- DM Channel 6

KINO-690S1 Mini-ITX Motherboard

- DM Channel 7

→ Reserved Memory Size [Disabled]

Use the **Reserved Memory Size** BIOS option to specify the amount of memory that should be reserved for legacy ISA devices.

- | | | | |
|---|-----------------|----------------|---|
| → | Disabled | DEFAULT | No memory block reserved for legacy ISA devices |
| → | 16K | | 16KB reserved for legacy ISA devices |
| → | 32K | | 32KB reserved for legacy ISA devices |
| → | 64K | | 54KB reserved for legacy ISA devices |

6.5 Boot

Use the Boot menu (BIOS Menu 14) to configure system boot options.

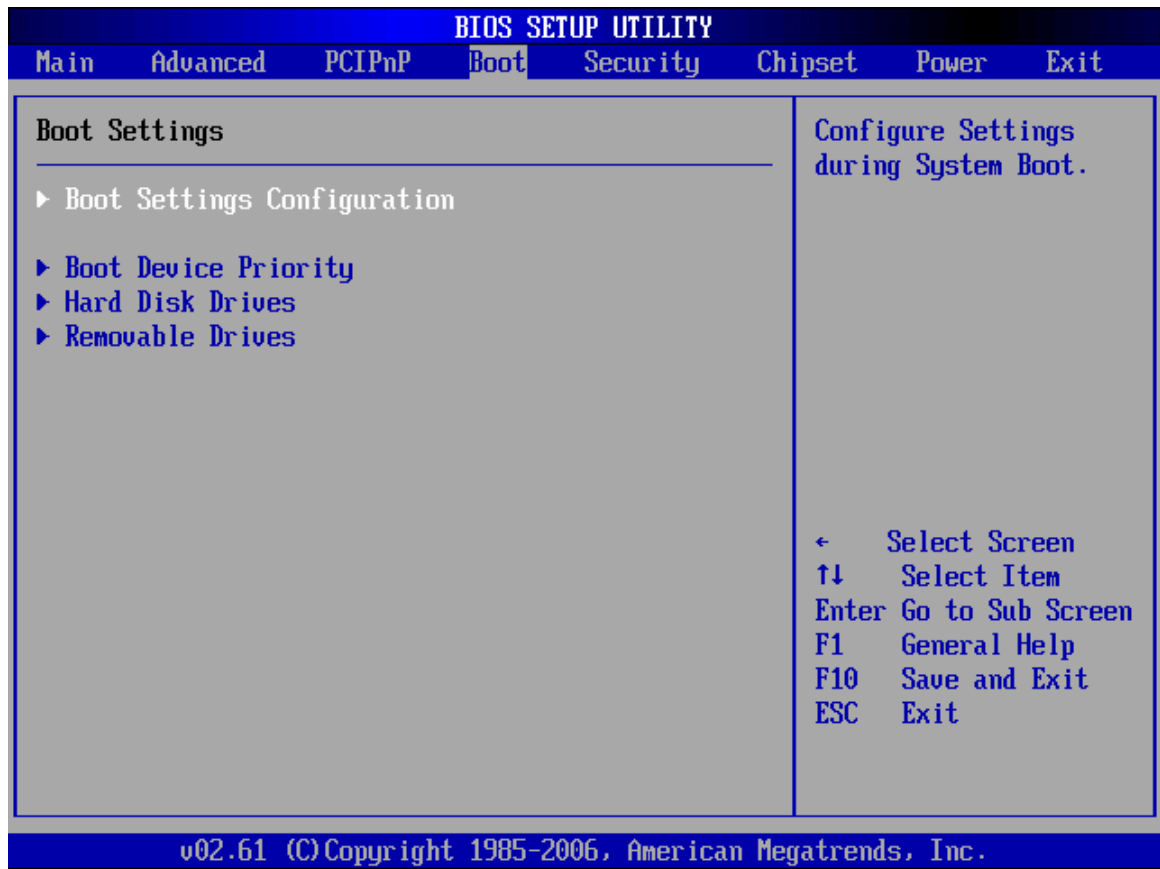

BIOS Menu 14: Boot

6.5.1 Boot Settings Configuration

Use the Boot Settings Configuration menu (BIOS Menu 14) to configure advanced system boot options.

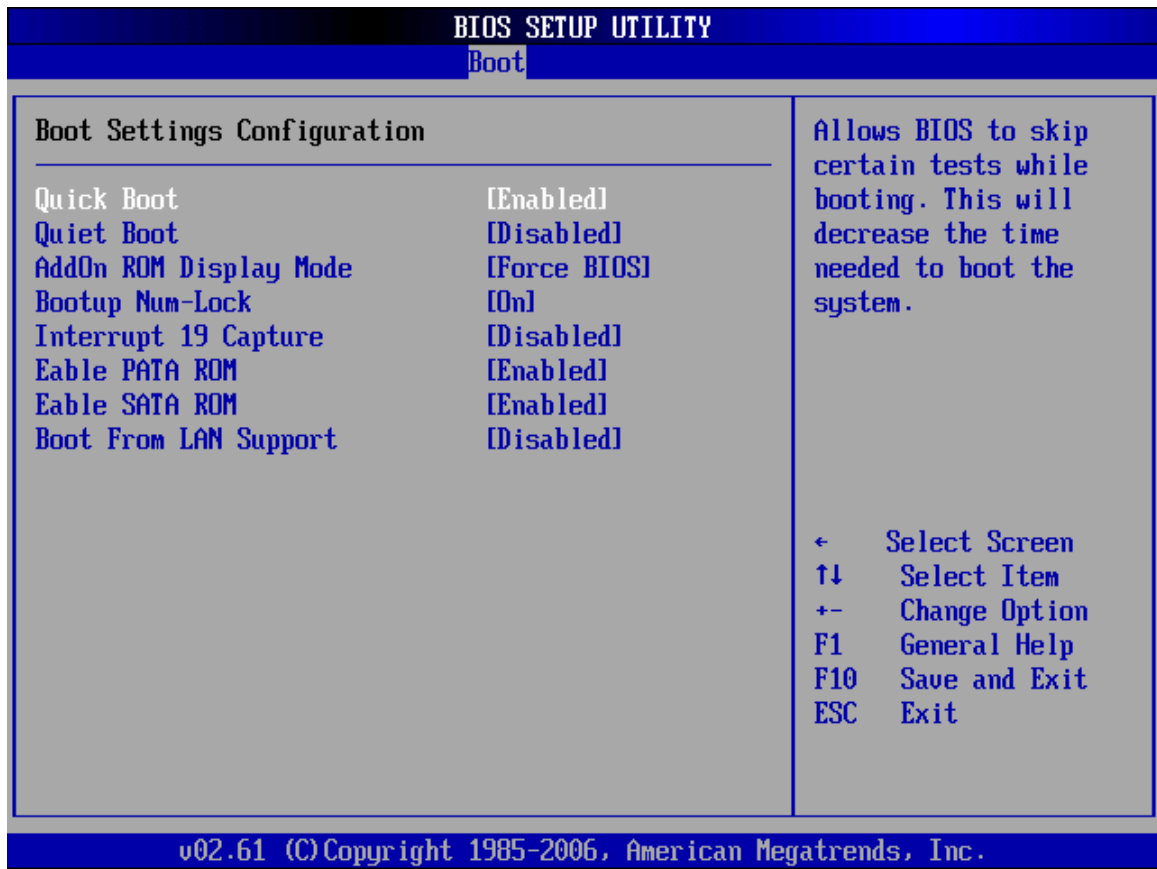

BIOS Menu 15: Boot Settings Configuration

→ Quick Boot [Enabled]

Use the **Quick Boot** BIOS option to make the computer speed up the boot process.

- **Disabled** No POST procedures are skipped
- **Enabled** **DEFAULT** Some POST procedures are skipped to decrease the system boot time

→ Quiet Boot [Disabled]

Use the **Quiet Boot** BIOS option to select the screen display when the system boots.

- **Disabled** **DEFAULT** Normal POST messages displayed

→ **Enabled** OEM Logo displayed instead of POST messages

→ **PS/2 Mouse Support [Enabled]**

Use the **PS/2 Mouse Support** option adjusts PS/2 mouse support capabilities.

→ **Disabled** PS/2 mouse support is disabled and prevented from using system resources.

→ **Enabled** **DEFAULT** Allows the system to use a PS/2 mouse.

→ **Auto** The system auto-adjusts PS/2 mouse support.

→ **Boot From LAN Support [Disabled]**

Use the **BOOT From LAN Support** option to enable the system to be booted from a remote system.

→ **Disabled** (Default) Cannot be booted from a remote system through the LAN

→ **Enabled** (Default) Can be booted from a remote system through the LAN

6.5.2 Boot Device Priority

Use the **Boot Device Priority** menu (**BIOS Menu 16**) to specify the boot sequence from the available devices. The following options are available:

- 1st Boot Device
- 2nd Boot Device

KINO-690S1 Mini-ITX Motherboard

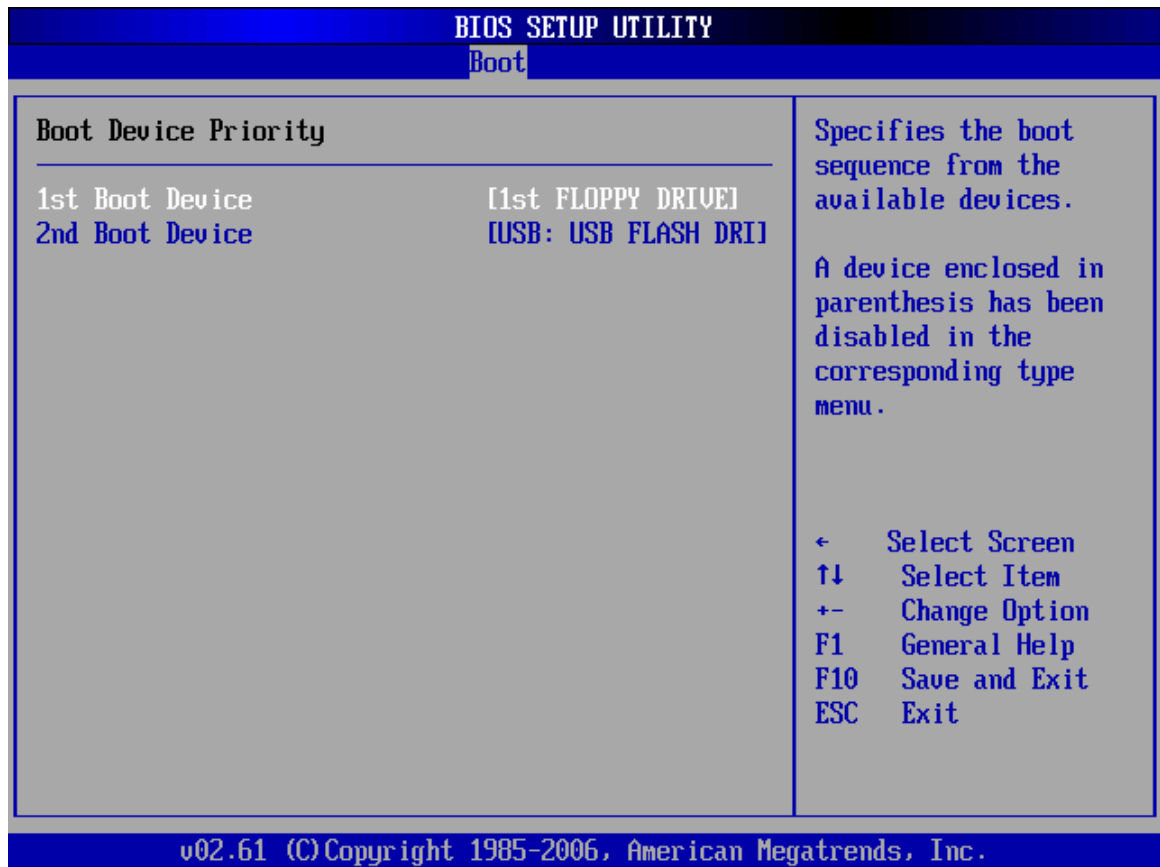

BIOS Menu 16: Boot Device Priority Settings

6.5.3 Hard Disk Drives

Use the **Hard Disk Drives** menu to specify the boot sequence of the available HDDs.

When the menu is opened, the HDDs connected to the system are listed as shown below:

- 1st Drive [HDD: PM-(part number)]
- 2nd Drive [HDD: PS-(part number)]
- 3rd Drive [HDD: SM-(part number)]
- 4th Drive [HDD: SM-(part number)]

NOTE:

Only the drives connected to the system are shown. For example, if only two HDDs are connected only “**1st Drive**” and “**2nd Drive**” are listed.

The boot sequence from the available devices is selected. If the “**1st Drive**” option is selected a list of available HDDs is shown. Select the first HDD the system boots from. If the “**1st Drive**” is not used for booting this option may be disabled.

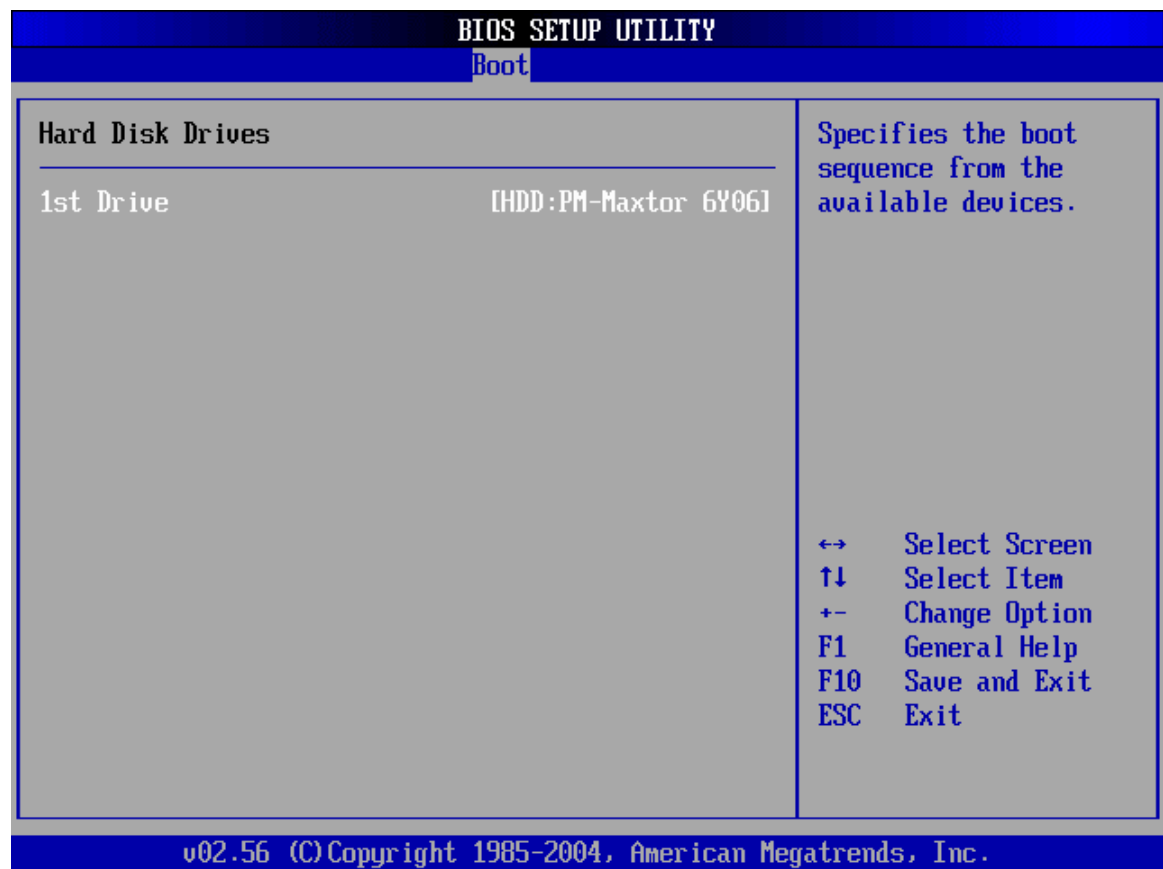

BIOS Menu 17: Hard Disk Drives

6.5.4 CD/DVD Drives

Use the **CD/DVD Drives** menu to specify the boot sequence of the available CD/DVD drives. When the menu is opened, the CD drives and DVD drives connected to the system are listed as shown below:

- 1st Drive [CD/DVD: PM-(part ID)]



NOTE:

Only the drives connected to the system are shown. For example, if only two CDs or DVDs are connected only “**1st Drive**” and “**2nd Drive**” are listed.

The boot sequence from the available devices is selected. If the “**1st Drive**” option is selected a list of available CD/DVD drives is shown. Select the first CD/DVD drive the system boots from. If the “**1st Drive**” is not used for booting this option may be disabled.

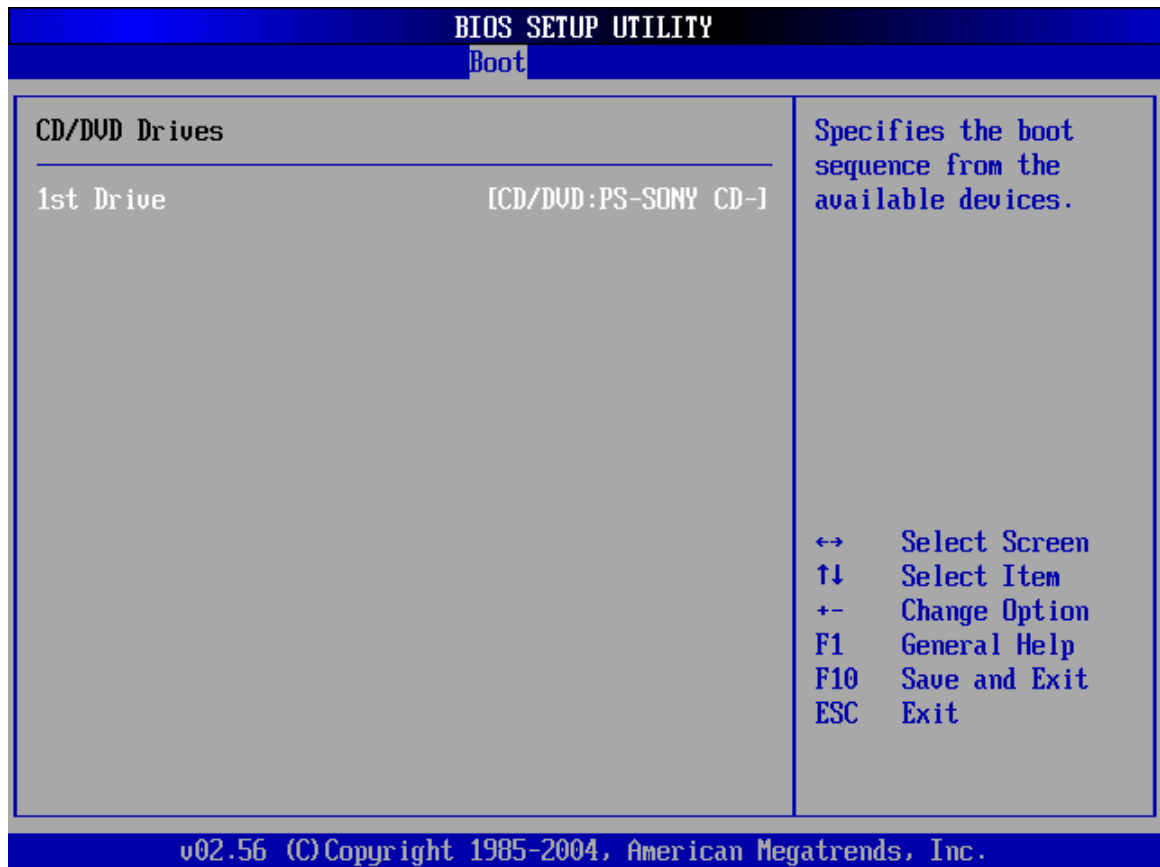

BIOS Menu 18: CD/DVD Drives

6.6 Security

Use the Security menu (BIOS Menu 19) to set system and user passwords.

KINO-690S1 Mini-ITX Motherboard

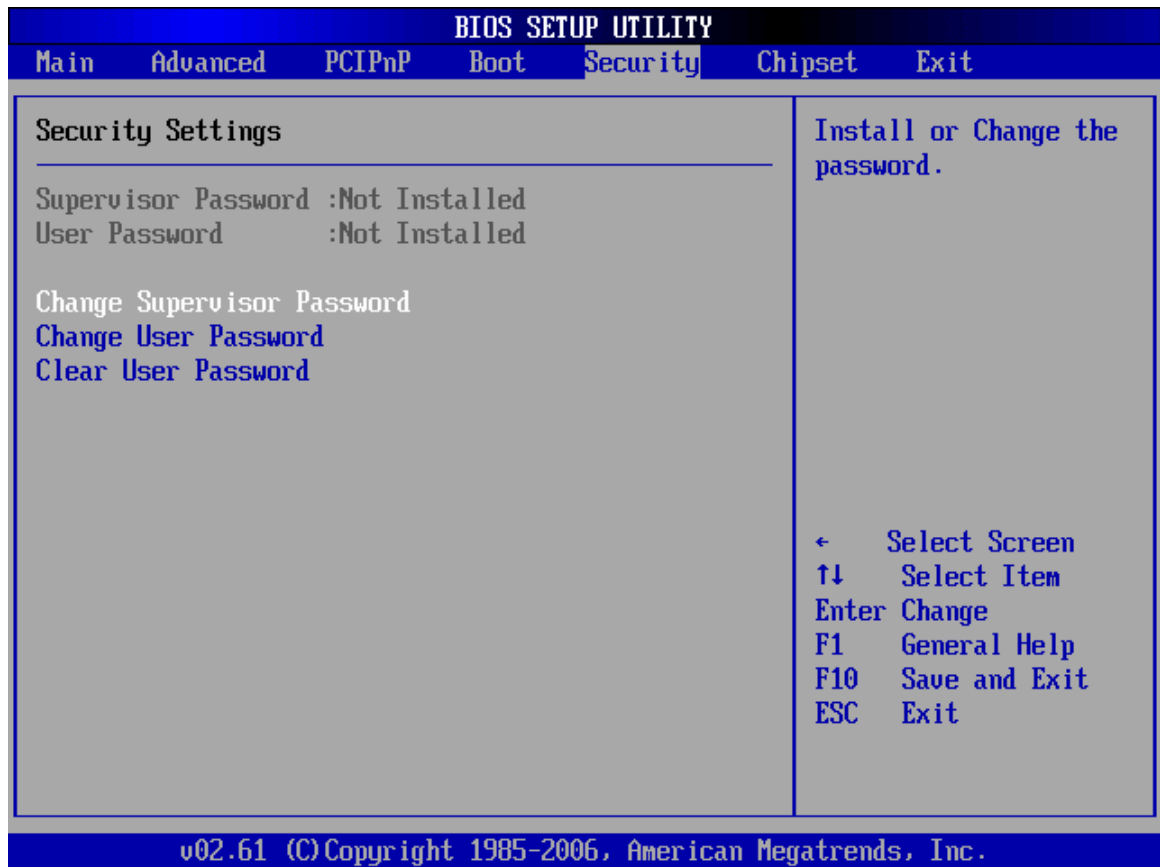
**BIOS Menu 19: Security****→ Change Supervisor Password**

Use the **Change Supervisor Password** to set or change a supervisor password. The default for this option is **Not Installed**. If a supervisor password must be installed, select this field and enter the password. After the password has been added, **Install** appears next to **Change Supervisor Password**.

→ Change User Password

Use the **Change User Password** to set or change a user password. The default for this option is **Not Installed**. If a user password must be installed, select this field and enter the password. After the password has been added, **Install** appears next to **Change User Password**.

→ Boot Sector Virus Protection [Disabled]

Use the **Boot Sector Virus Protection** to enable the system to protect the computer boot sector from viruses.

- **Disabled** (Default) Disables the boot sector virus protection
- **Enabled** Enables the boot sector virus protection

6.7 Chipset

Use the **Chipset** menu (**BIOS Menu 20**) to access the NorthBridge and SouthBridge configuration menus



WARNING!

Setting the wrong values for the Chipset BIOS selections in the Chipset BIOS menu may cause the system to malfunction.

KINO-690S1 Mini-ITX Motherboard

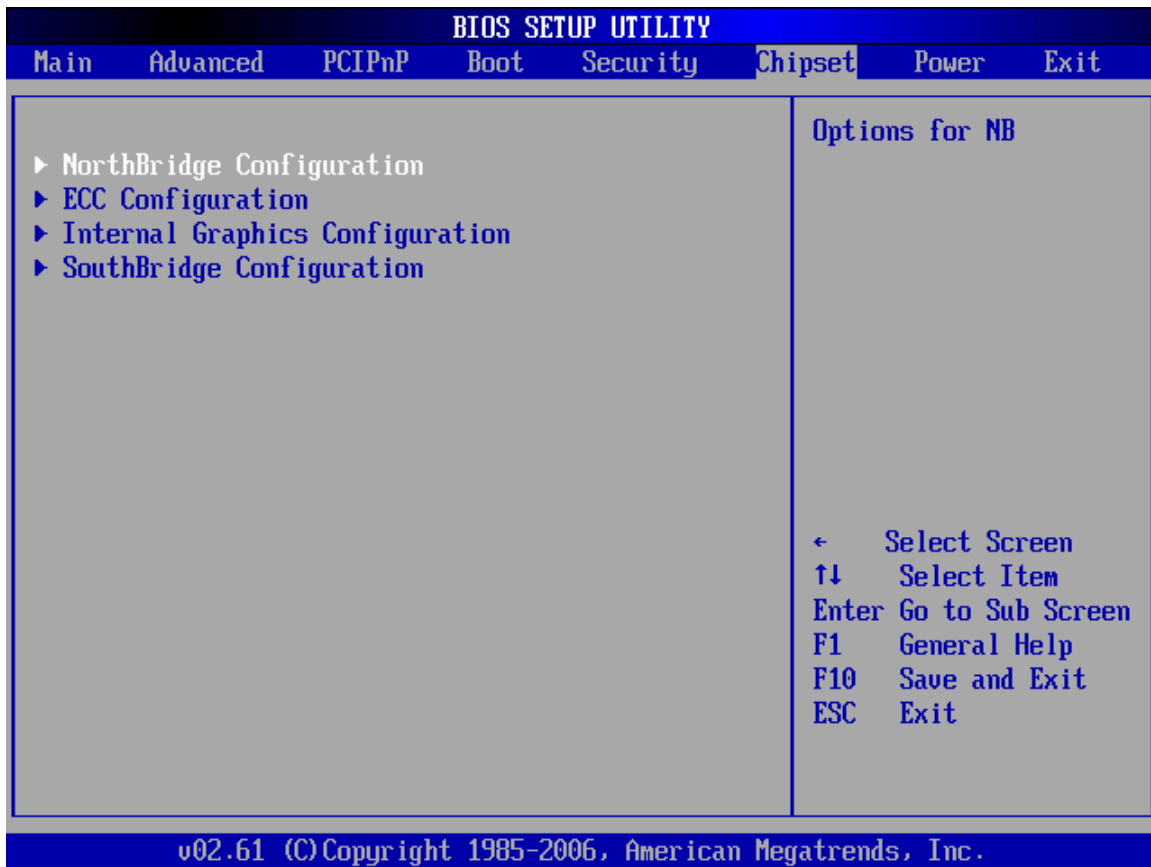

BIOS Menu 20: Chipset

6.7.1 NorthBridge Chipset Configuration

Use the NorthBridge Chipset Configuration menu (BIOS Menu 20) to check the northbridge chipset settings.

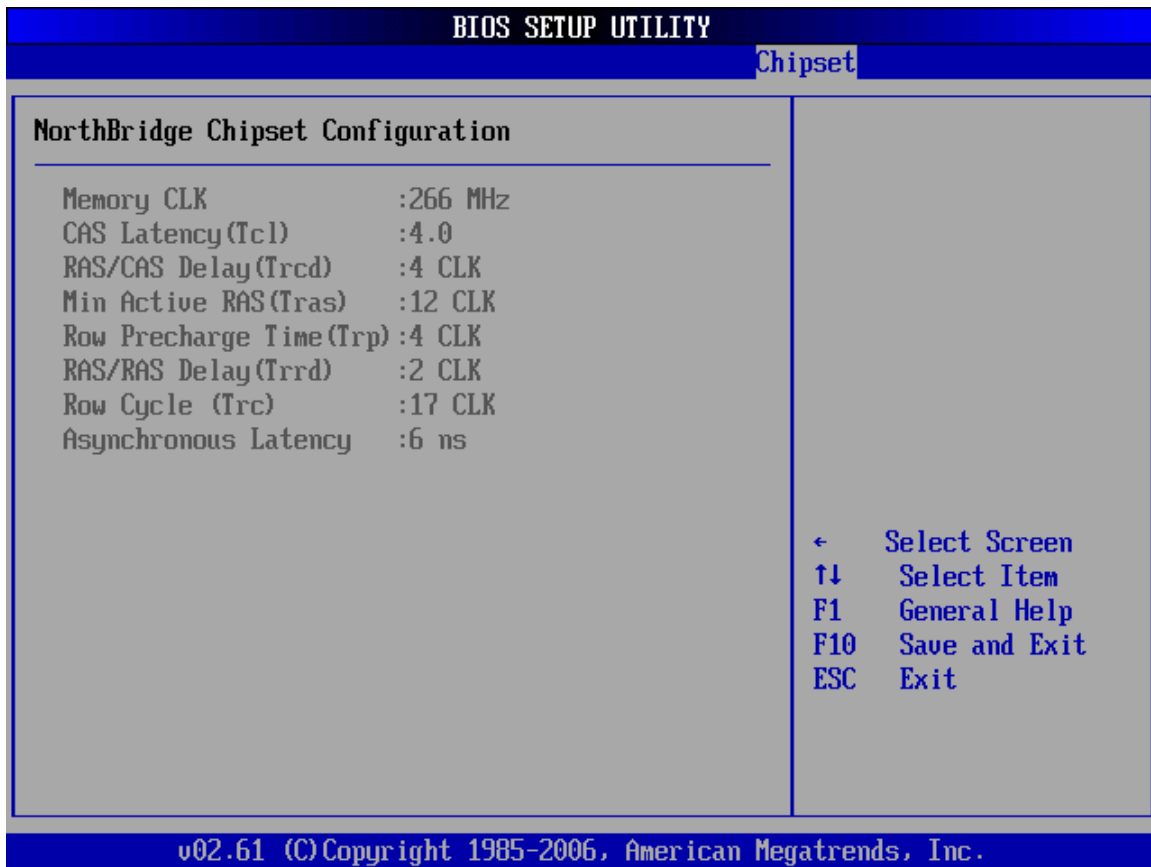

BIOS Menu 21:NorthBridge Chipset Configuration

The NorthBridge Chipset configuration menu has no configurable options. The NorthBridge Chipset configuration menu shows the following Northbridge chipset settings:

- **Memory CLK:** Shows the speed of the memory controller
- **CAS (Latency):** Specifies the Column Address Strobe (CAS) delay time
- **RAS/CAS Delay(Trcd):** Specifies the number of clock cycles that must elapse between sending a RAS (row address strobe) signal and the CAS (column address strobe) signal.
- **Min Active RAS (Tras):** Specifies the speed at which the RAM terminates the access of one row and start accessing another.
- **Row Precharge Time(Trp):** Specifies the length of the delay between the activation and precharge commands for the RAS signal.
- **RAS/RAS Delay(Trrd):**

KINO-690S1 Mini-ITX Motherboard

- Row Cycle (Trc):
- Asynchronous Latency:

6.7.2 ECC Configuration

Use the **ECC Configuration** menu (**BIOS Menu 22**) to set the ECC parameters.

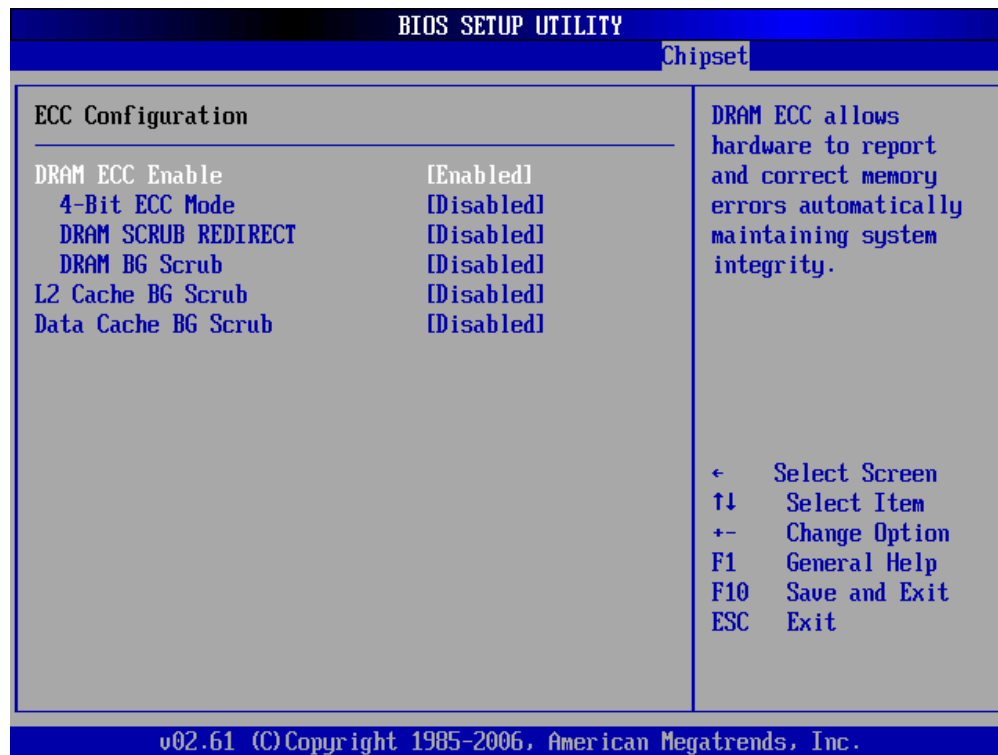

BIOS Menu 22: ECC Configuration Chipset Configuration

→ DRAM ECC Enable [Enabled]

Use the **DRAM ECC Enable** option to enable the hardware to report and correct memory errors and thereby automatically maintain the system.

- **Disabled** System cannot report and correct memory errors
- **Enabled (Default)** System can report and correct memory errors

→ 4-Bit ECC Mode

Use the **4-Bit ECC Mode** to enable or disable the 4-Bit ECC mode (a.k.a. CHIPKILL ECC MODE)

- **Disabled** 4-Bit ECC mode disabled
- **Enabled** (Default) 4-Bit ECC mode enabled

→ **DRAM SCRUB REDIRECT [Disabled]**

Use the **DRAM SCRUB REDIRECT** option to enable the system to immediately correct DRAM ECC errors when they occur, even when background scrubbing is on.

- **Disabled** (Default) System cannot immediately correct DRAM ECC errors
- **Enabled** System cannot immediately correct DRAM ECC errors

→ **DRAM BG Scrub [Disabled]**

Use the **DRAM BG Scrub** option to enable the system to immediately correct memory errors so later reads are correct. Doing this while memory is not being used improves performance.



NOTE:

When the AMD node interleave feature is enabled, BIOS will force DRAM scrub off.

-
- **Disabled** (Default) System cannot immediately correct memory errors
 - **Enabled** System cannot immediately correct memory errors

→ **L2 Cache BG Scrub [Disabled]**

KINO-690S1 Mini-ITX Motherboard

Use the **L2 Cache BG Scrub** option to enable the system to correct the L2 Data cache when idle.

- ➔ **Disabled** (Default) L2 cache can be corrected when the system is idle.
- ➔ **Enabled** L2 cache cannot be corrected when the system is idle.

➔ L1 Cache BG Scrub [Disabled]

Use the **L1 Cache BG Scrub** option to enable the system to correct the L1 Data cache when idle.

- ➔ **Disabled** (Default) L1 cache can be corrected when the system is idle.
- ➔ **Enabled** L1 cache cannot be corrected when the system is idle.

6.7.3 Internal Graphics Configuration

Use the **Internal Graphics Configuration (BIOS Menu 23)** menu to set the integrated graphics.

memory.

→ UMA Buffer Size [Auto]

Use the **UMA Buffer Size** option to specify the memory to be reserved for the integrated graphics. The following configuration options are available:

- Auto (Default)
- 32MB
- 64MB
- 128MB
- 256MB
- 512MB
- 1024MB

→ Current UMA Buffer Size [Auto]

The current UMA Buffer Size field specifies the amount of memory that is allocated to the integrated graphics.

→ Primary Video Controller [IGFX]

Use the **Primary Video Controller** option to select the primary video graphics controller the system uses. The following options are available:

- PCIE
- PCI
- IGFX

→ TV Standard

Use the **TV Standard** option to specify the TV type connected to the system.

- **NTSC** **DEFAULT** TV type is set to NTSC
- **PAL** TV type is set to PAL
- **PAL-M** TV type is set to PAL-M

→ PAL-N TV type is set to PAL-N

→ Expansion Mode [Disabled]

Use the **Expansion Mode** option to enable or disable the expansion mode.

→ Disabled **DEFAULT** Expansion mode disabled

→ Enabled Expansion mode enabled

6.7.4 SouthBridge Configuration

The **SouthBridge Configuration** menu (BIOS Menu 24) the southbridge chipset to be configured.

KINO-690S1 Mini-ITX Motherboard

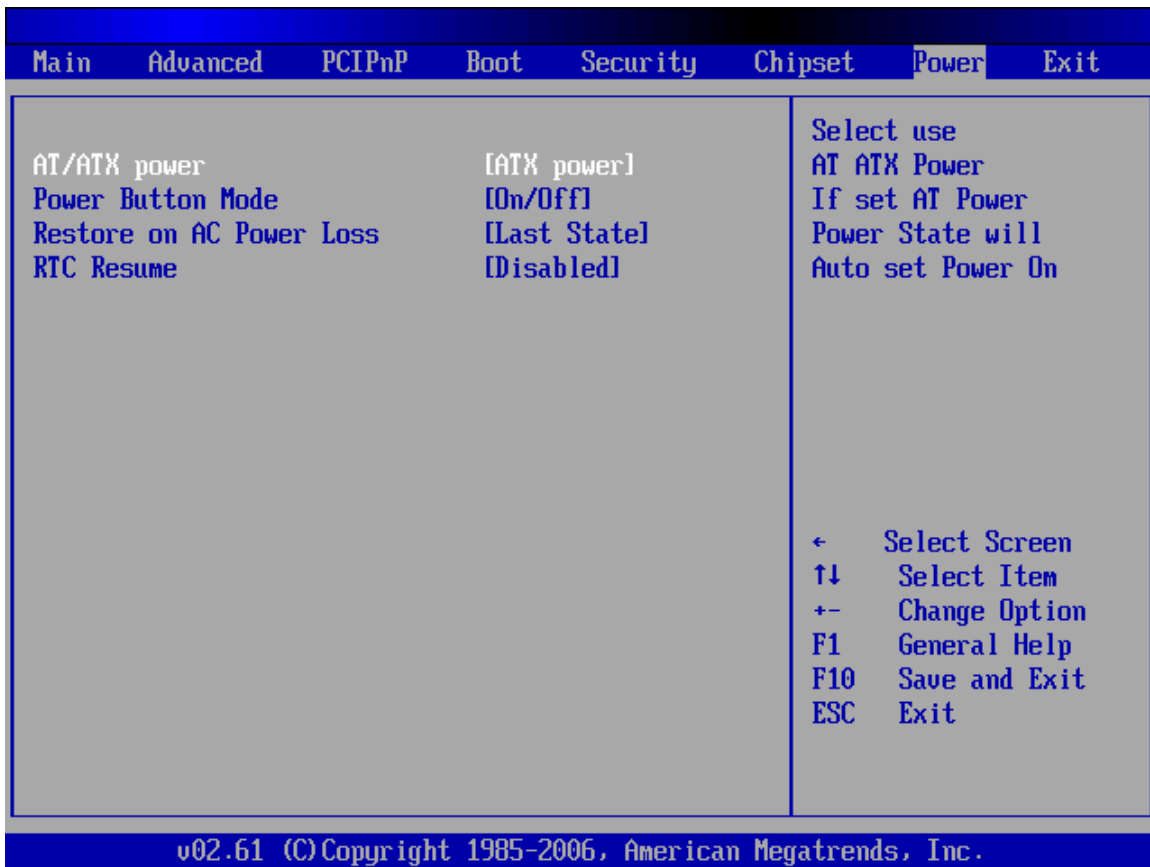

BIOS Menu 24:SouthBridge Chipset Configuration

→ AC97 Audio Device

Use the **AC97 Audio Device** option to enable or disable the AC'97 CODEC.

- **Disabled** The onboard AC'97 is disabled
- **Auto** (Default) The onboard AC'97 automatically detected and enabled

→ Set Spread Spectrum Function [Disabled]

Use the **Set Spread Spectrum** BIOS option to improve CPU EMI issues.

- **Disabled** (Default) The clock spread spectrum is disabled
- **Enabled** The clock spread spectrum is enabled

→ OnChip SATA [Enabled]

Use the **OnChip SATA** option to enable or disable the SATA controller on the Southbridge.

- Disabled** Disables the Southbridge SATA controller.
- Enabled** **DEFAULT** Enables the Southbridge SATA controller.

→ OnChip SATA Type [Enabled]

Use the **OnChip SATA Type** option to specify the drive type that is installed in the system/
The following options are available:

- Native IDE
- RAID
- AHCI
- Legacy IDE
- IDE → AHCI

6.8 Power

The **Power** menu (**BIOS Menu 25**) allows the advanced power management options to be configured.

KINO-690S1 Mini-ITX Motherboard

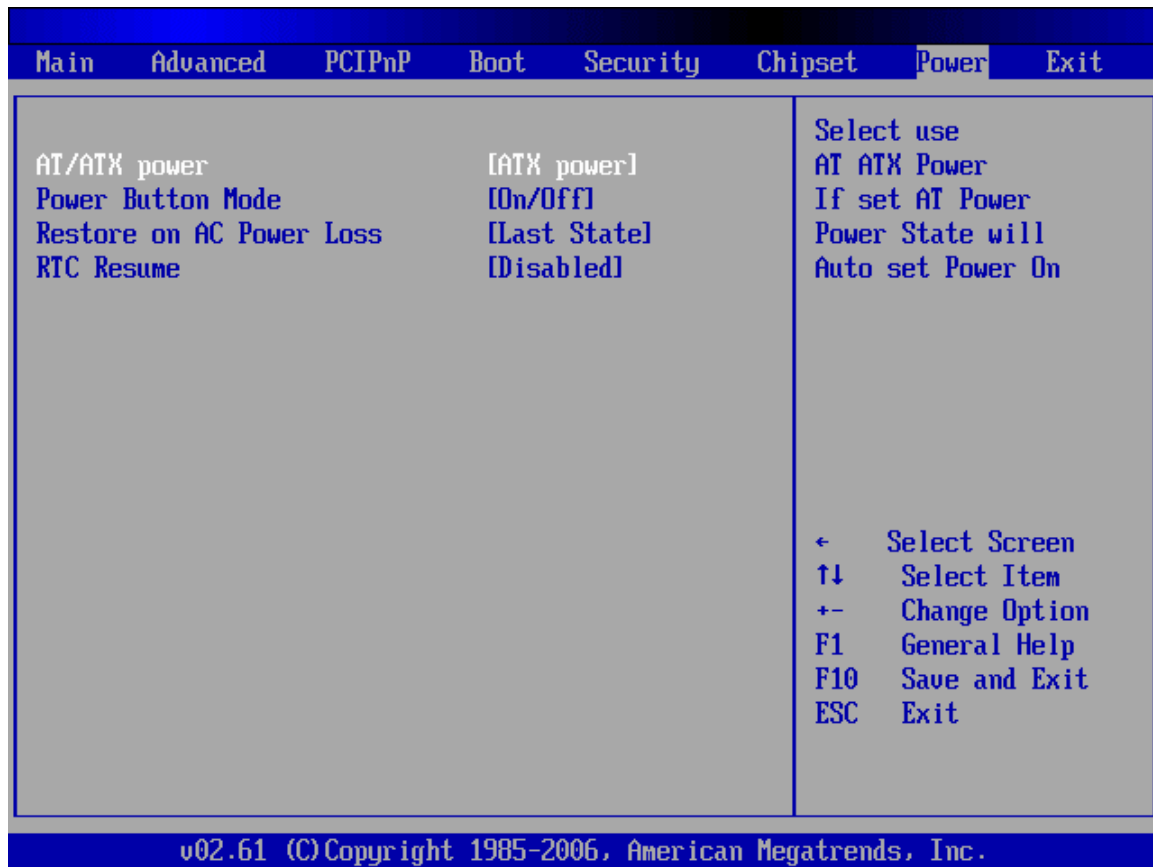

BIOS Menu 25:Power

→ Power Management/APM [Enabled]

Use the **Power Management/APM** BIOS option to enable access to the advanced power management features. If this option is disabled, the only other option on the screen is the **Power Button Mode**.

→ **Disabled** Disables the Advanced Power Management (APM) feature

→ **Enabled** (Default) Enables the APM feature

→ Power Button Mode [On/Off]

Use the **Power Button Mode** BIOS to specify how the power button functions.

- **On/Off** (Default) When the power button is pressed the system is either turned on or off
- **Suspend** When the power button is pressed the system goes into suspend mode

→ **Resume on Ring [Disabled]**

Use the **Resume on Ring** option to enable the system to be roused from a suspended or standby state when there is activity on the RI (ring in) modem line. That is, the system is roused by an incoming call on a modem.

- **Disabled** (Default) Wake event not generated by an incoming call
- **Enabled** Wake event generated by an incoming call

→ **AT/ATX Power [ATX]**

Use the **AT/ATX Power** BIOS option to select the power supply that is connected to the system.

- **AT** An AT power supply is connected to the system
- **ATX** **DEFAULT** An ATX power supply is connected to the system

→ **Restore on AC Power Loss [Last State]**

The **Restore on AC Power Loss** BIOS option specifies what state the system returns to if there is a sudden loss of power to the system.

- **Power Off** The system remains turned off
- **Power On** The system turns on
- **Last State** (Default) The system returns to its previous state. If it was on, it turns itself on. If it was off, it remains off.

KINO-690S1 Mini-ITX Motherboard

→ Resume On RTC Alarm [Disabled]

Use the **Resume On RTC Alarm** option to specify the time the system should be roused from a suspended state.

→ **Disabled** (Default) The real time clock (RTC) cannot generate a wake event

→ **Enabled** If selected, the following appears with values that can be selected:

→ RTC Alarm Date (Days)

→ System Time

After setting the alarm, the computer turns itself on from a suspend state when the alarm goes off.

6.9 Exit

Use the **Exit** menu (**BIOS Menu 26**) to load default BIOS values, optimal failsafe values and to save configuration changes.

BIOS Menu 26:Exit
→ Save Changes and Exit

Use the **Save Changes and Exit** option to save the changes made to the BIOS options and to exit the BIOS configuration setup program.

→ Discard Changes and Exit

Use the **Discard Changes and Exit** option to exit the BIOS configuration setup program without saving the changes made to the system.

→ Discard Changes

Use the **Discard Changes** option to discard the changes and remain in the BIOS configuration setup program.

KINO-690S1 Mini-ITX Motherboard

→ Load Optimal Defaults

Use the **Load Optimal Defaults** option to load the optimal default values for each of the parameters on the Setup menus. **F9 key can be used for this operation.**

→ Load Failsafe Defaults

Use the **Load Failsafe Defaults** option to load failsafe default values for each of the parameters on the Setup menus. **F8 key can be used for this operation.**



THIS PAGE IS INTENTIONALLY LEFT BLANK

Chapter

7

Software Drivers

7.1 Available Software Drivers

**NOTE:**

The content of the CD may vary throughout the life cycle of the product and is subject to change without prior notice. Visit the IEI website or contact technical support for the latest updates.

The following drivers can be installed on the system:

- AMD chipset driver
- LAN driver
- Audio driver

Installation instructions are given below.

7.2 Driver CD Auto-run

All the drivers for the KINO-690S1 are on the CD that came with the system. To install the drivers, please follow the steps below.

Step 1: Insert the CD into a CD drive connected to the system.

**NOTE:**

If the system does not initiate the "autorun" program when the CD is inserted, click the **Start** button, select **Run**, then type **X:\autorun.exe** (where **X:** is the system CD drive) to access the IEI Driver CD main menu.

Step 2: The driver main menu appears (**Figure 7-1**).

KINO-690S1 Mini-ITX Motherboard



Figure 7-1: Introduction Screen

Step 3: Click KINO-690S1.

Step 4: A new screen with a list of available drivers appears (Figure 7-2).

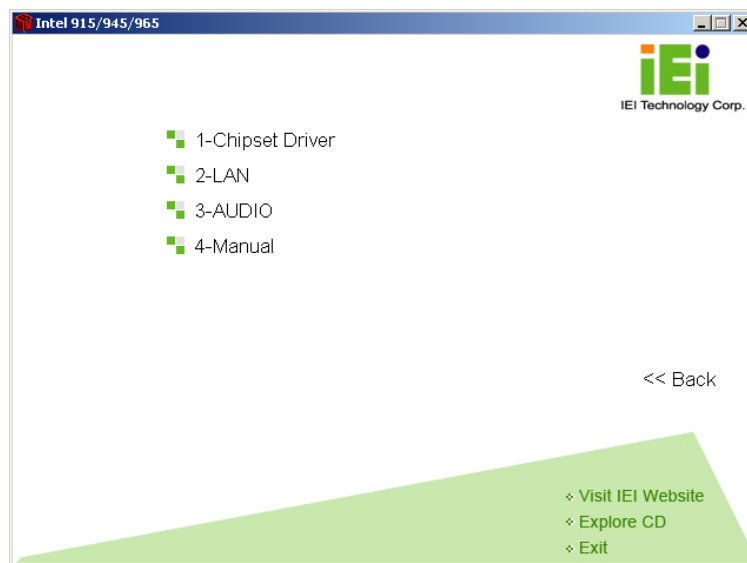

Figure 7-2: Available Drivers

Step 5: Select the driver to install from the list in **Figure 7-2**. Detailed driver installation instructions follow below.

7.3 AMD 690G Chipset Driver Installation

To install the chipset driver, please follow the steps below.



NOTE:

The chipset driver control center requires Microsoft .NET Framework prior to installation. The driver control center is an application that allows a user to control the configuration of the AMD product. To verify .NET Framework, check the Add/Remove Programs list in the Control Panel. If the .NET Framework is not listed, please download, and install it.

Step 1: Select **Chipset** from the list in **Figure 7-2**.

Step 2: A new window opens (Figure 7-3).

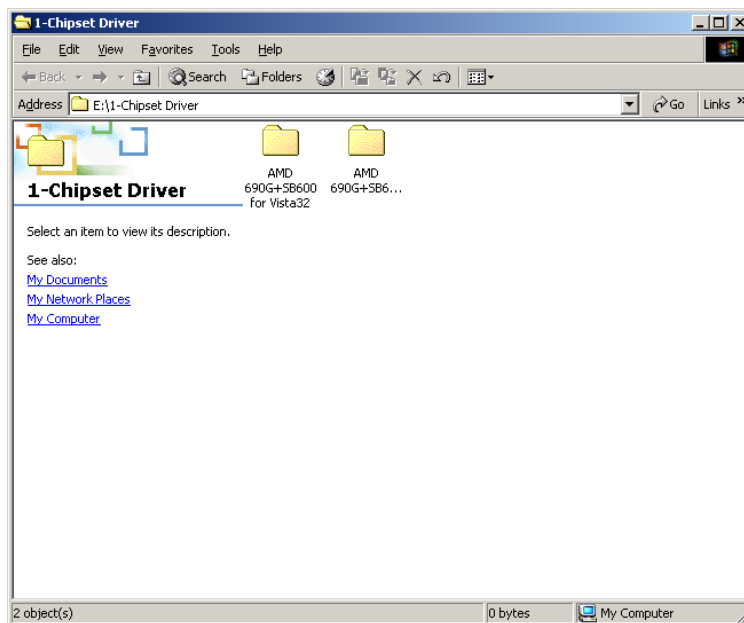

Figure 7-3: Chipset Driver Installation Program

Step 3: Double-click the directory icon for the operating system that is running on the system.

KINO-690S1 Mini-ITX Motherboard

Step 4: The screen in **Figure 7-4** appears.

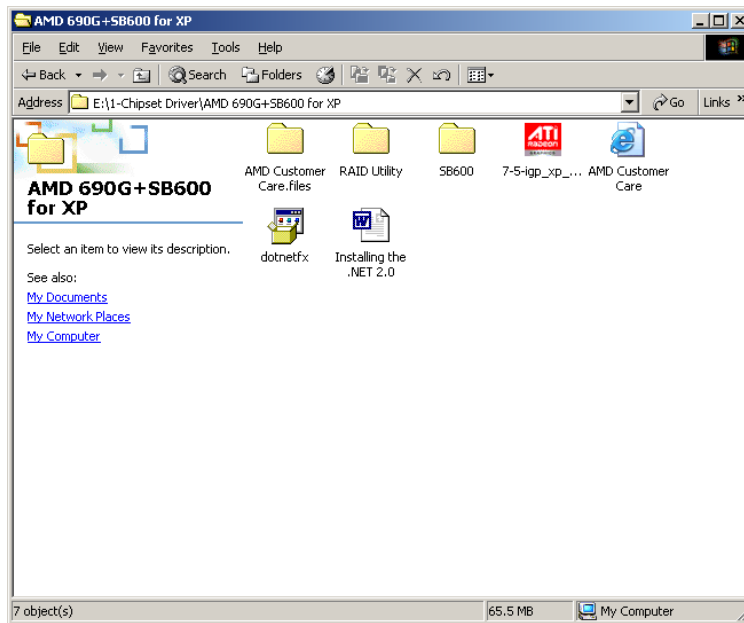

Figure 7-4: Chipset Driver Installation Welcome Screen

Step 5: Open the **SB600** directory. The screen in **Figure 7-5** appears.

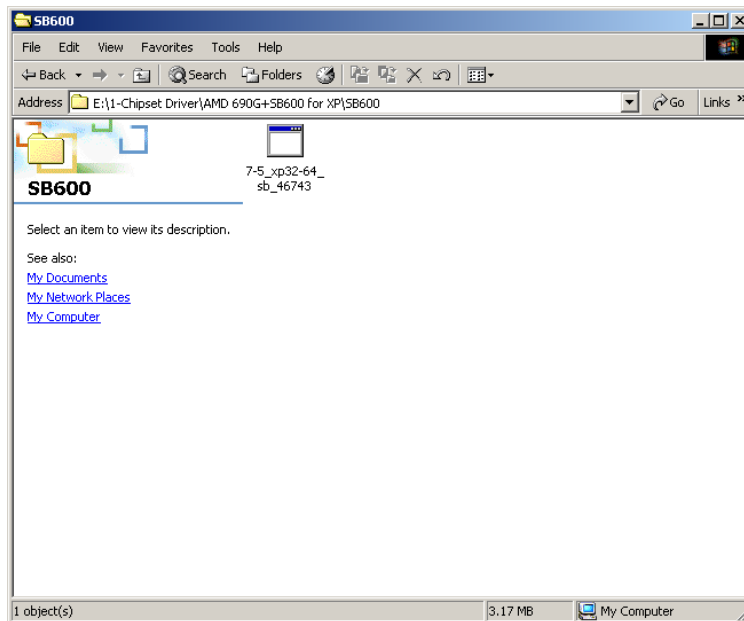

Figure 7-5: Chipset Driver Installation License Agreement

Step 6: The screen in **Figure 7-6** appears. Select the destination folder.

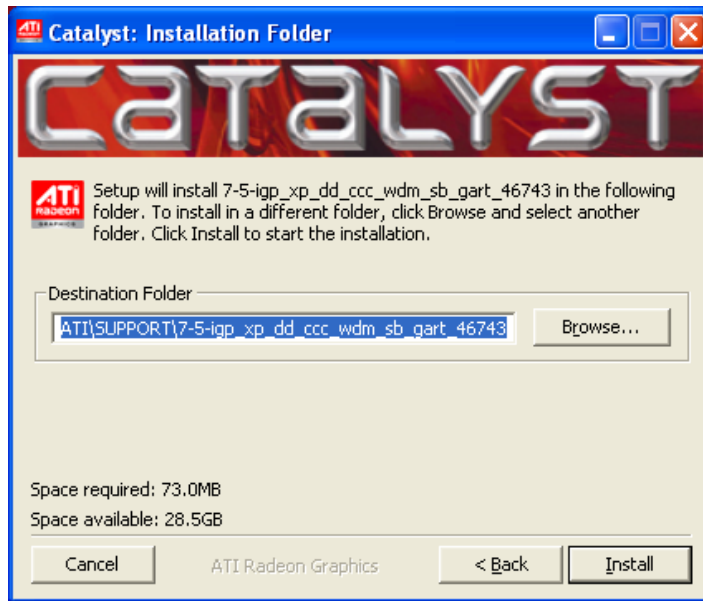

Figure 7-6: Select Destination Folder

Step 7: Click install to continue.

Step 8: The screen in **Figure 7-7** appears as the driver starts to install.

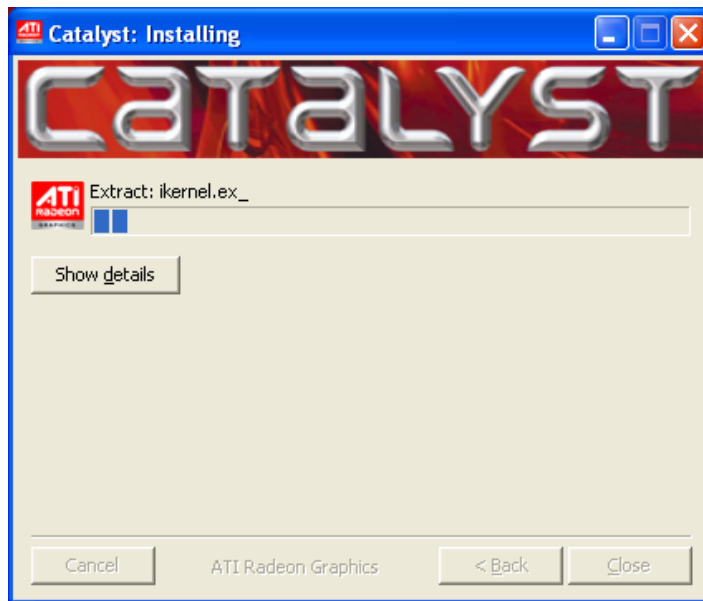

Figure 7-7: Chipset Driver Installing Screen

Step 9: The welcome screen shown in **Figure 7-8** appears.

KINO-690S1 Mini-ITX Motherboard

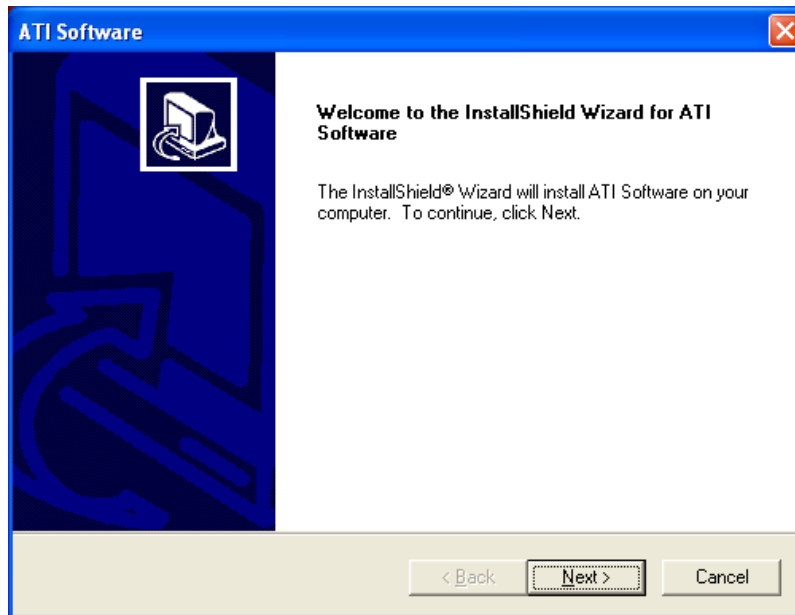

Figure 7-8: Welcome Screen

Step 10: Click YES to continue.

Step 11: The License agreement file in Figure 7-9 appears.

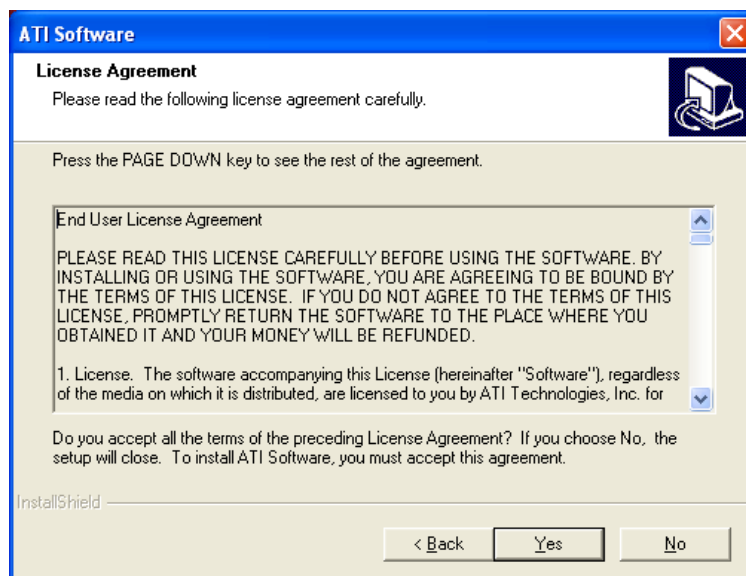

Figure 7-9: Chipset Driver Readme File Information

Step 12: Click YES to continue.

Step 13: The screen in Figure 7-10 appears.

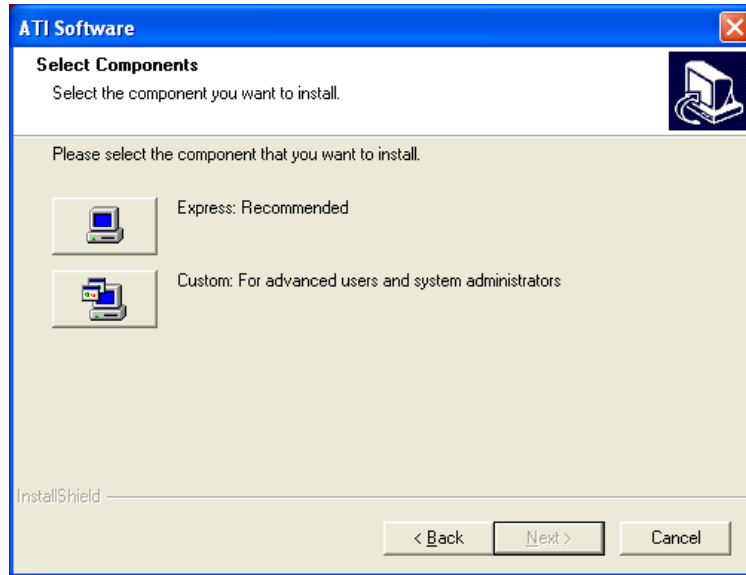

Figure 7-10: Chipset Driver Installation Complete

Step 14: Select the installation type (Express or Custom) then click Next to continue.

Step 15: The installer starts to load the display driver.

Step 16: Next the WDM Capture drivers load (for VIVO or All-In-Wonder)

Step 17: The Catalyst Control Center setup starts shortly after.

Step 18: A dialog box indicates the install progress.

Step 19: When the installation is complete the **Setup Complete** screen in **Figure 7-11** appears.

KINO-690S1 Mini-ITX Motherboard

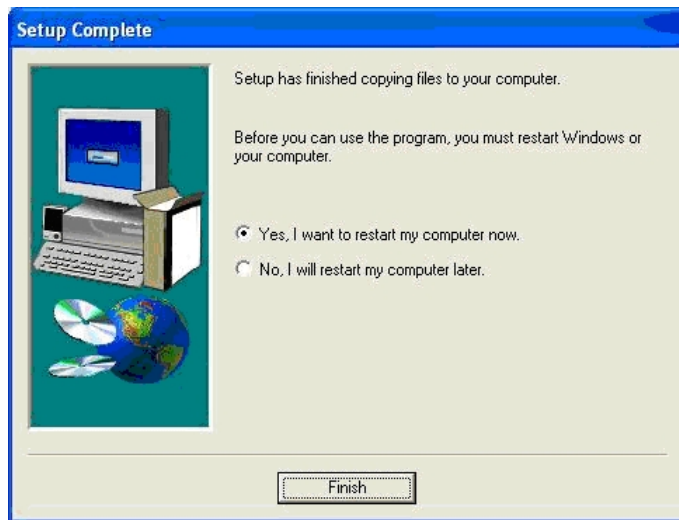

Figure 7-11: Setup Complete

Step 20: To complete the installation, click **Finish**.

7.4 Broadcom LAN Driver (for GbE LAN) Installation

To install the Broadcom LAN driver, please follow the steps below.

Step 1: Open **Windows Control Panel** (Figure 7-12).

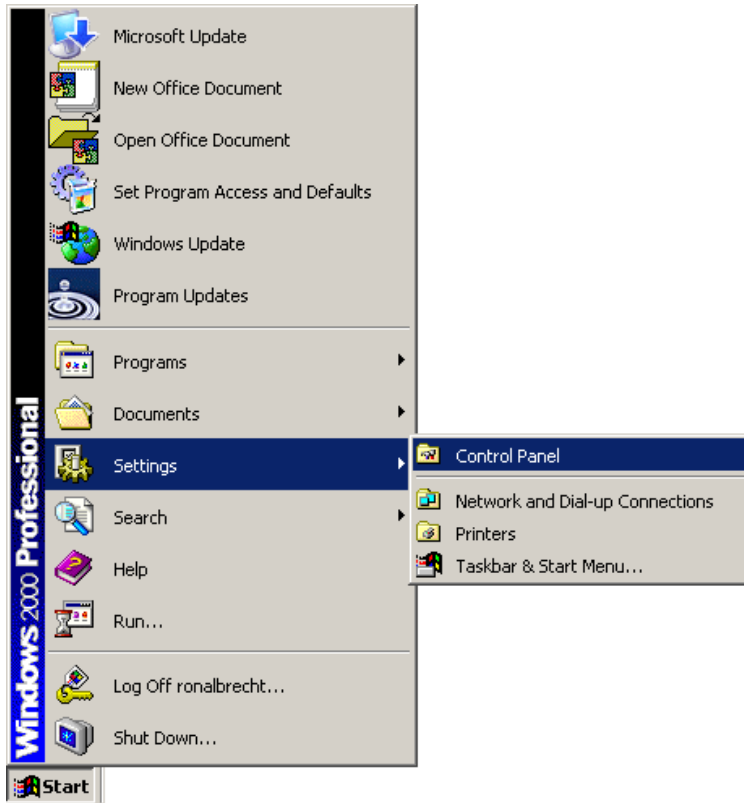

Figure 7-12: Windows Control Panel

Step 2: Double-click the **System** icon.

KINO-690S1 Mini-ITX Motherboard

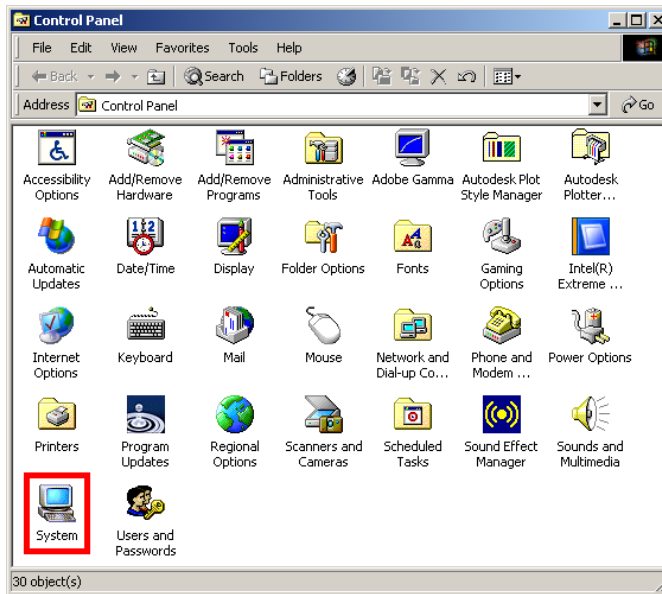

Figure 7-13: System Icon

Step 3: Click the **Device Manager** tab (Figure 7-14).

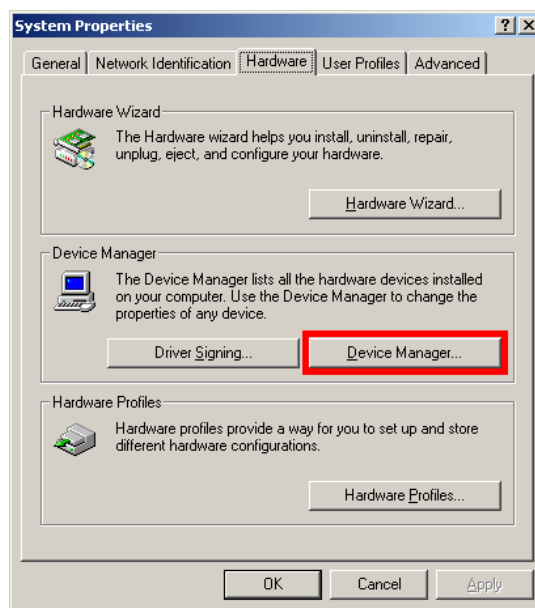

Figure 7-14: Device Manager Tab

Step 4: A list of system hardware devices appears (Figure 7-15).

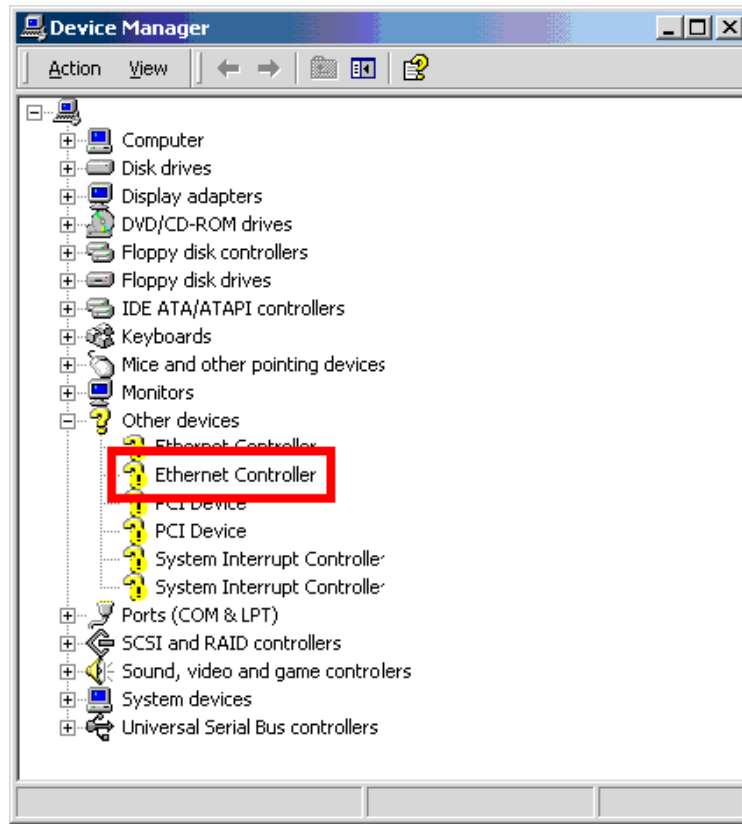

Figure 7-15: Device Manager List

- Step 5:** Double-click the listed device that has question marks next to it (this means Windows does not recognize the device).
- Step 6:** The **Device Driver Wizard** appears (Figure 7-16).

KINO-690S1 Mini-ITX Motherboard



Figure 7-16: Search for Suitable Driver

Step 7: Select “**Search for a suitable driver for my device (recommended),**” and click **NEXT** to continue.

Step 8: Select “**Specify a Location**” in the **Locate Driver Files** window (Figure 7-18).

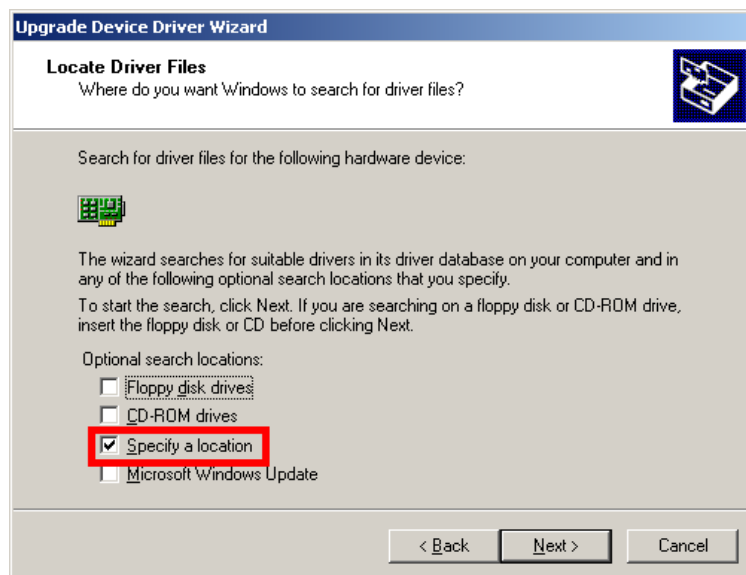

Figure 7-17: Locate Driver Files

Step 9: Click **NEXT** to continue.

Step 10: The **Locate File** window appears (Figure 7-18).

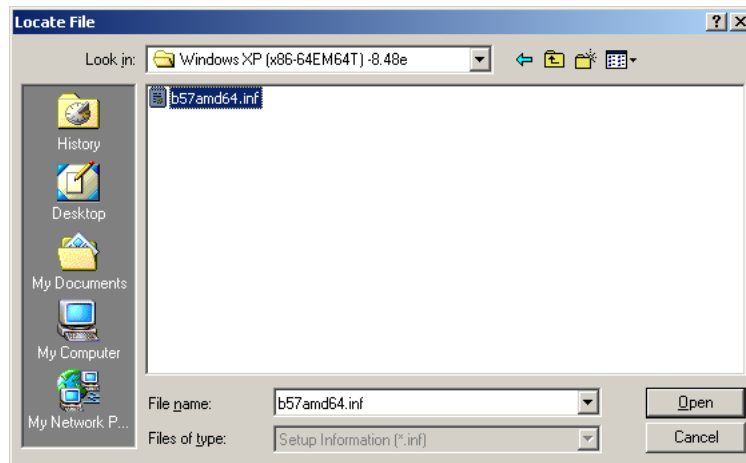

Figure 7-18: Location Browsing Window

Step 11: Select the proper OS folder under the “X:\13-LAN\BROADCOM BCM57xx Drivers” directory in the **Locate File** window, where “X:\” is the system CD drive.

Step 12: Click **OPEN** and the driver is installed.

7.5 Realtek AC`97 Audio Driver (ALC655) Installation

To install the Realtek AC `97 audio driver, please follow the steps below.

7.5.1 BIOS Setup

Step 1: Enter the BIOS setup. To do this, reboot the system and press **DEL** during POST.

Step 2: Go to the Southbridge Configuration menu. Set the **Audio Controller** option to [AC`97].

Step 3: Press **F10** to save the changes and exit the BIOS setup. The system reboots.

7.5.2 Driver Installation

To install the audio driver please follow the steps below.

Step 1: Select **AUDIO** from the list in **Figure 7-2**.

Step 2: A new window opens (Figure 7-19).

KINO-690S1 Mini-ITX Motherboard

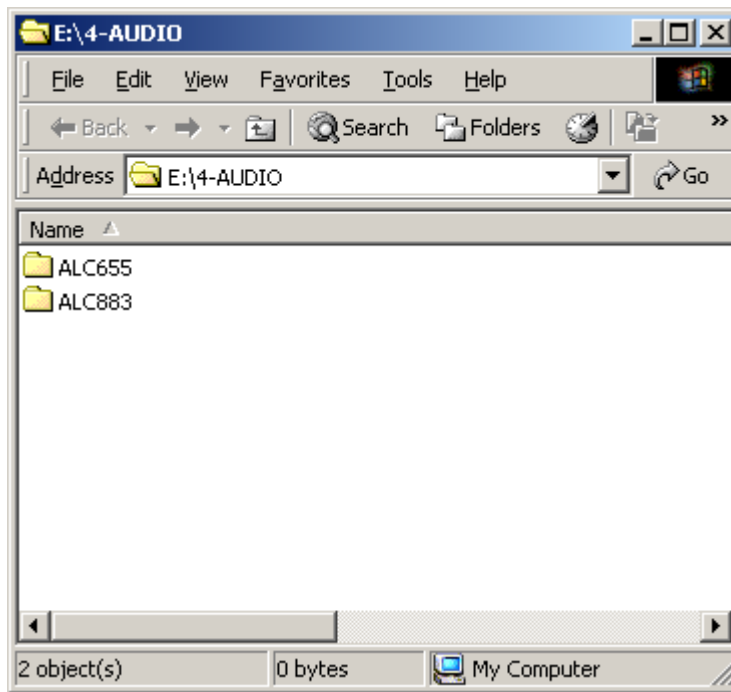

Figure 7-19: Select the Audio CODEC

Step 3: Double-click the ALC655 folder.

Step 4: Double-click the **Setup.exe** program icon in Figure 7-20.

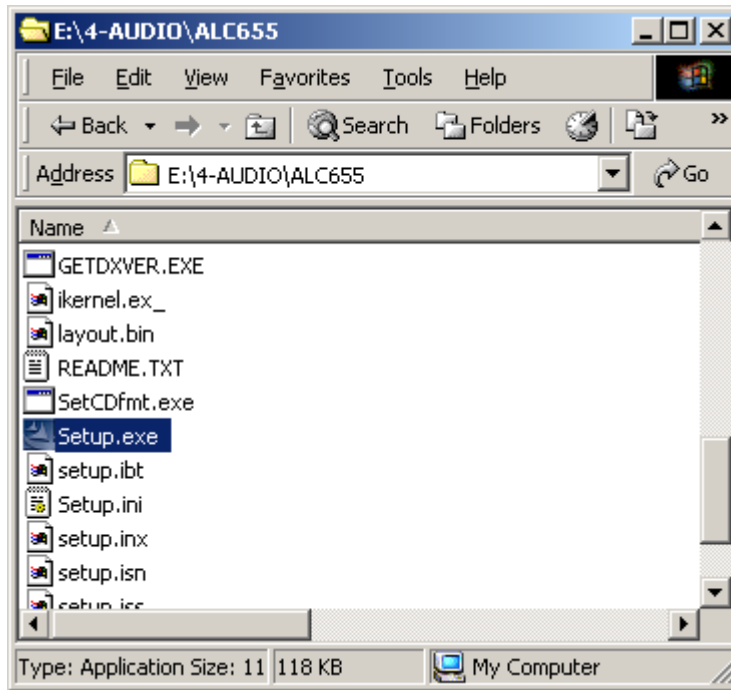

Figure 7-20: Locate the Setup Program Icon

Step 5: The InstallShield Wizard is prepared to guide the user through the rest of the process (Figure 7-21).

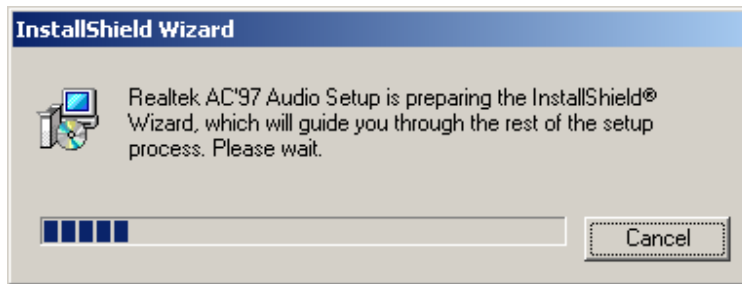

Figure 7-21: Preparing Setup Screen

Step 6: Once initialized, the InstallShield Wizard welcome screen appears (Figure 7-22).

KINO-690S1 Mini-ITX Motherboard

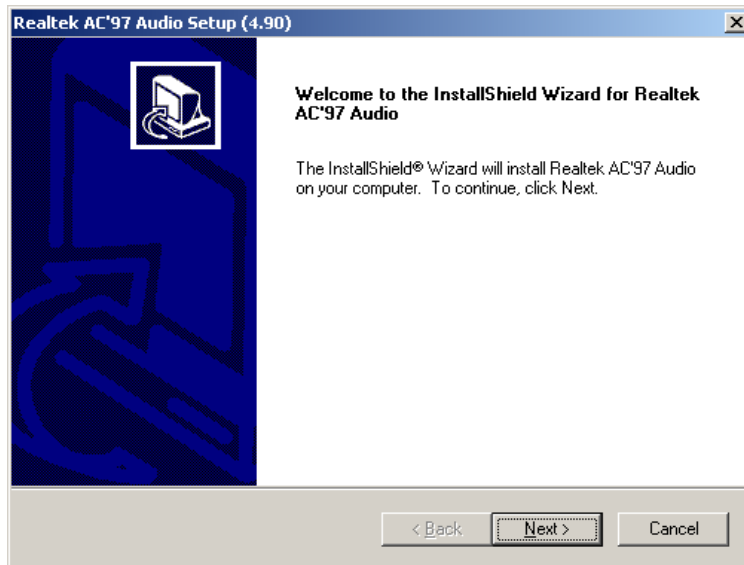

Figure 7-22: InstallShield Wizard Welcome Screen

Step 7: Click **NEXT** to continue the installation.

Step 8: InstallShield starts to install the new software as shown in Figure 7-23.

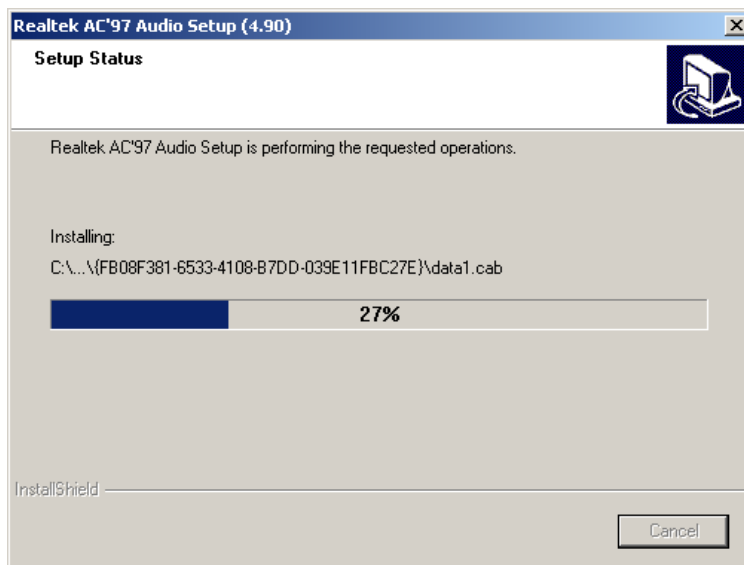

Figure 7-23: Audio Driver Software Configuration

Step 9: At this stage the **Digital Signal Not Found** screen shown in Figure 7-24 appears.



Figure 7-24: Audio Driver Digital Signal

Step 10: Click **YES** and the driver installation begins (Figure 7-25).

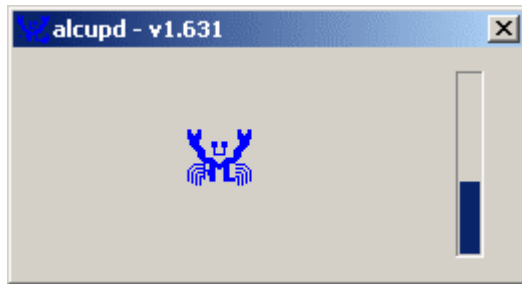

Figure 7-25: Audio Driver Installation

Step 11: After the driver installation process is complete, a confirmation screen appears (Figure 7-26).

KINO-690S1 Mini-ITX Motherboard

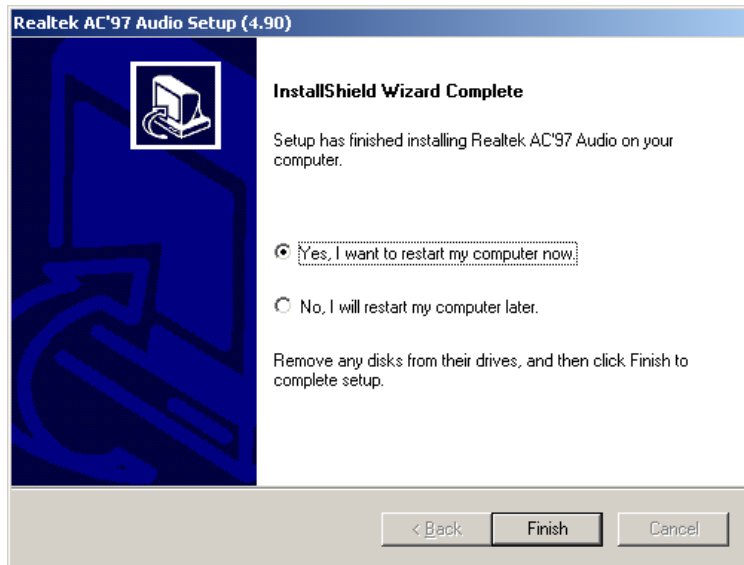

Figure 7-26: Restart the Computer

Step 12: The confirmation screen offers the option of restarting the computer now or later.

For the settings to take effect, the computer must be restarted. Click **FINISH** to restart the computer.

7.6 WebPAM RAID Utility Driver Installation

To install the AMD® Matrix Storage Manager driver, please follow the steps below:

Step 1: Select **Chipset** from the list in **Figure 7-2**.

Step 2: A new window opens (**Figure 7-27**).

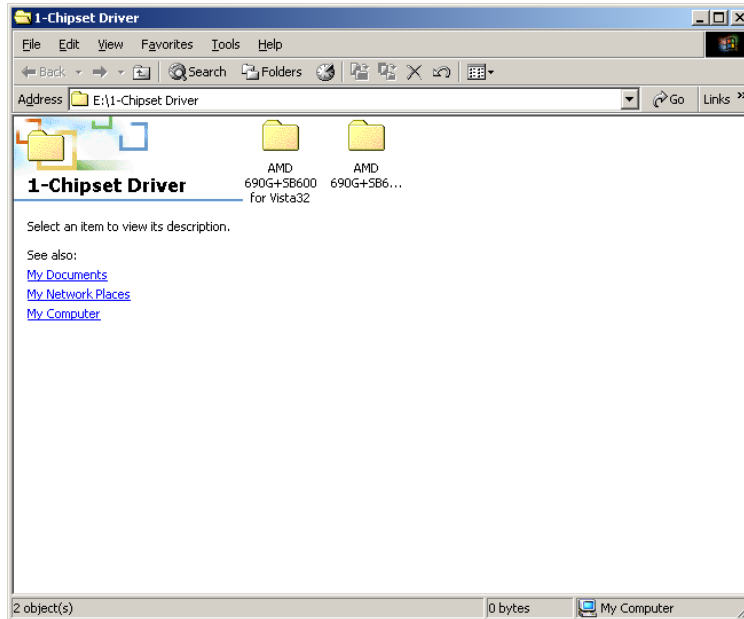

Figure 7-27: Chipset Driver Installation Program

Step 3: Double-click the directory icon for the operating system that is running on the system.

Step 4: The screen in **Figure 7-28** appears.

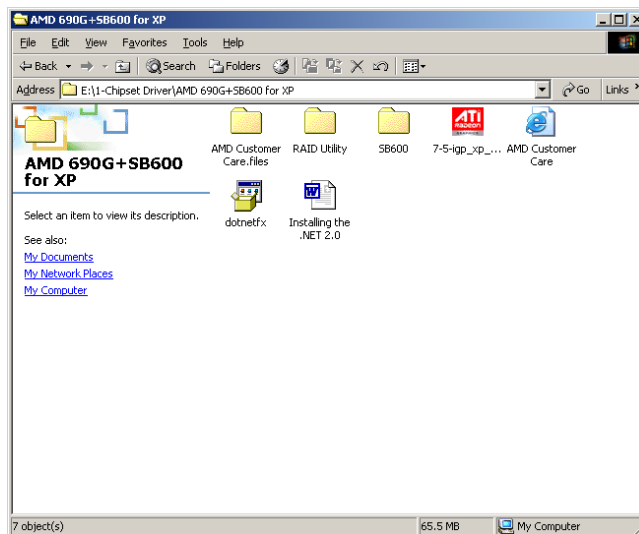

Figure 7-28: Chipset Drivers

Step 5: Open the **RAID Utility** from directory in **Figure 7-28**.

KINO-690S1 Mini-ITX Motherboard

Step 6: A new window opens (Figure 7-29).

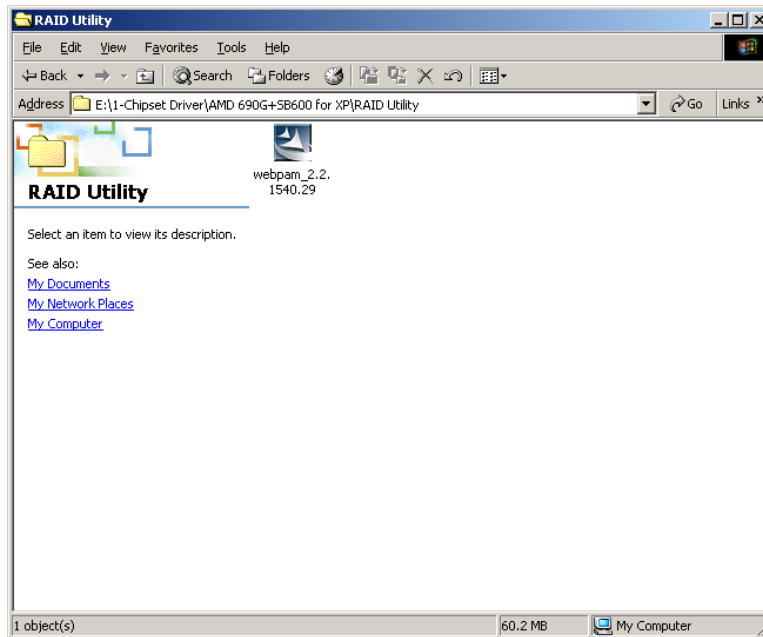

Figure 7-29: RAID Utility Icon

Step 7: Double-click the Icon Figure 7-29.

Step 8: The RAID Utility installation procedure is initiated as shown in Figure 7-30.

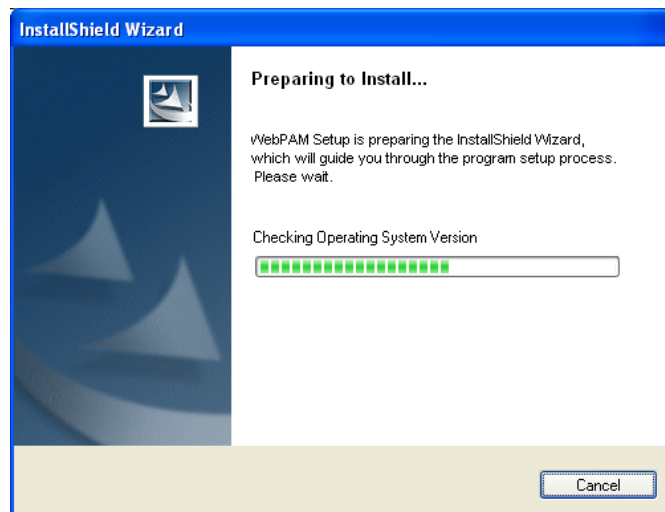

Figure 7-30: SATA RAID Setup Program Icon

Step 9: The welcome screen in Figure 7-31 appears.

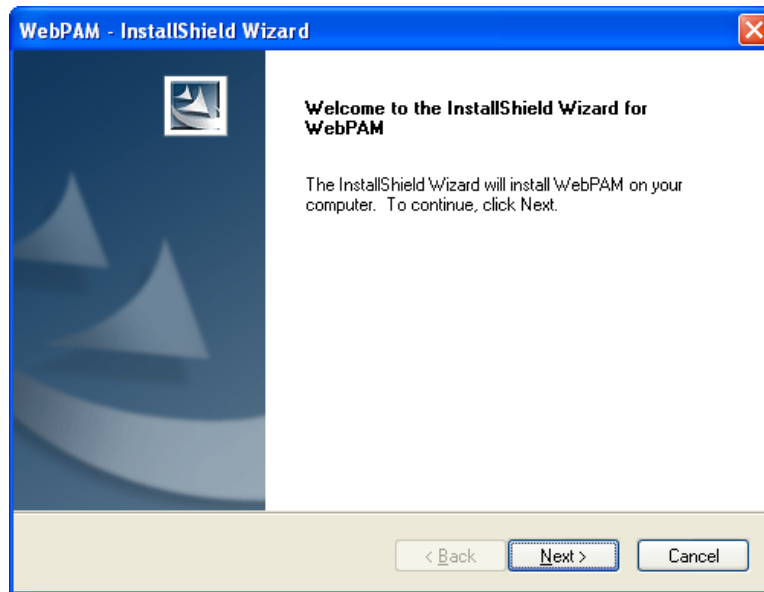

Figure 7-31: Welcome Screen

Step 10: Click **Next** to continue.

Step 11: The license agreement shown in **Figure 7-32** appears.

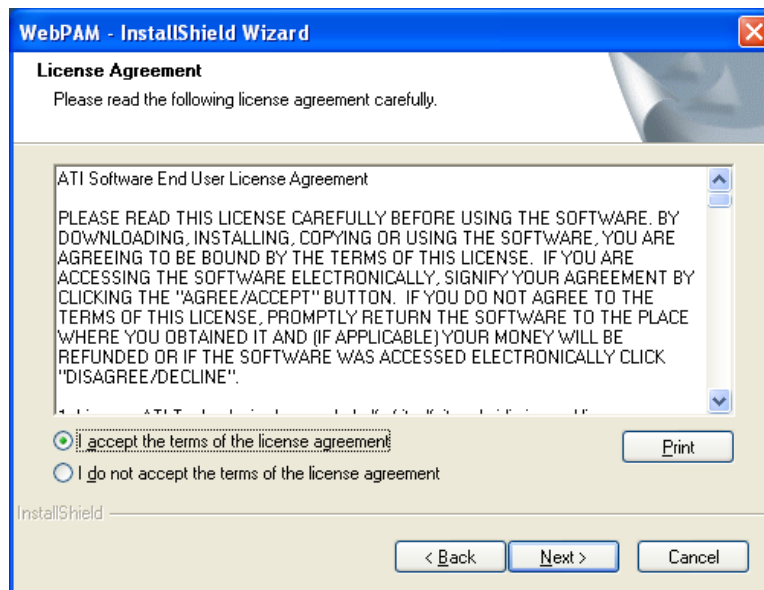

Figure 7-32: WebPAM License Agreement

Step 12: Click **Next** to continue.

KINO-690S1 Mini-ITX Motherboard

Step 13: The screen in **Figure 7-33** appears.

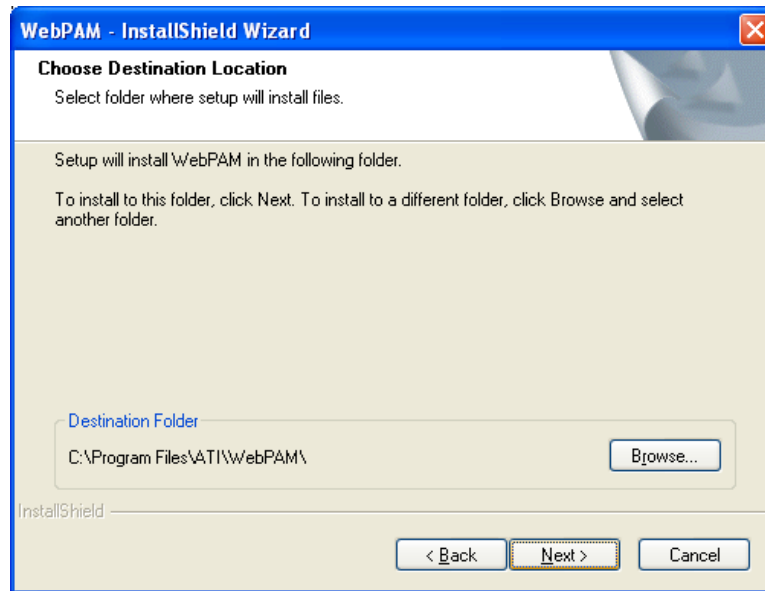

Figure 7-33: Select WebPAM Installation Destination

Step 14: Select the destination for the WebPAM. Click **NEXT** to continue.

Step 15: The Ready to Install Program screen in **Figure 7-34** appears.

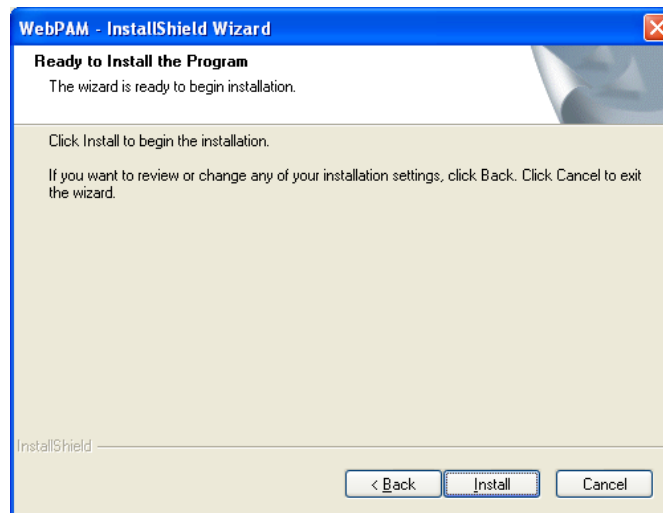

Figure 7-34: WebPAM Ready to Install

Step 16: Click **Install**.

Step 17: The WebPAM program begins to install as shown in **Figure 7-35**.

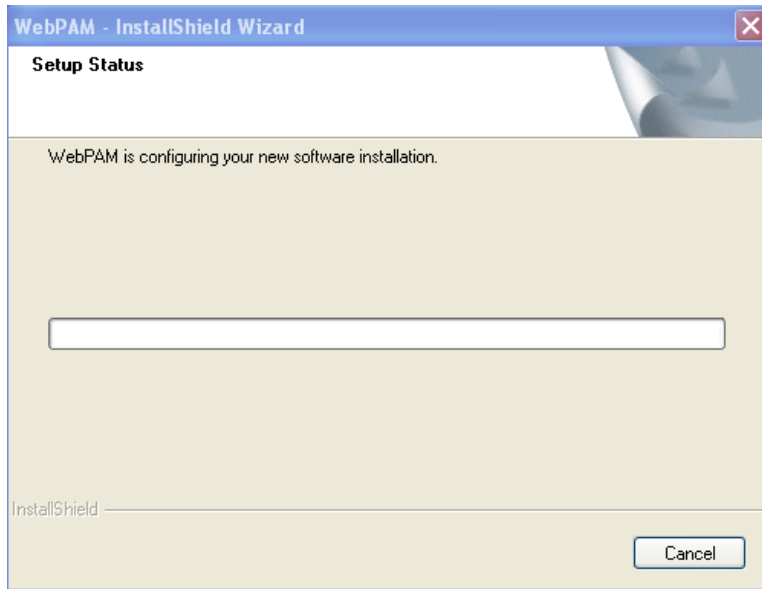

Figure 7-35: WebPAM Installation

Step 18: The Installation complete screen in **Figure 7-36** appears.

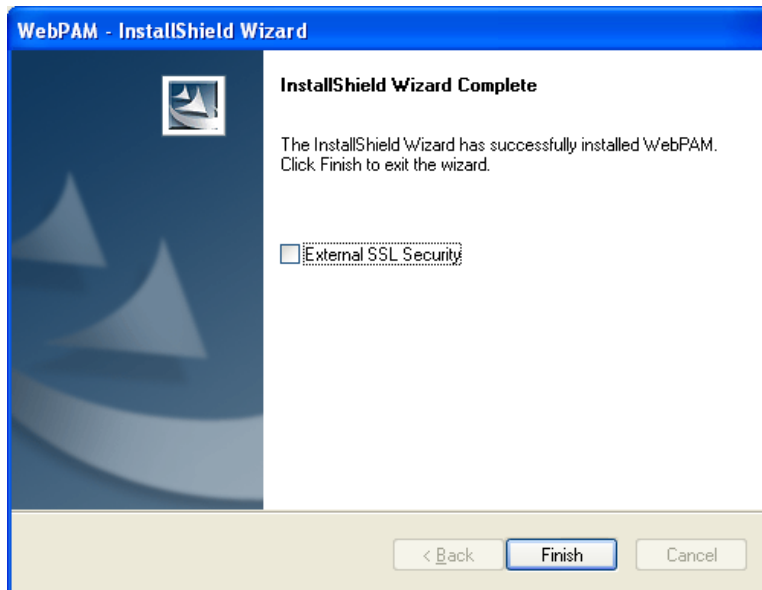

Figure 7-36: WebPAM Installation Complete

Step 19: Click **Finish** to complete WebPAM installation.

Appendix

A

BIOS Options

→	System Overview	100
→	System Time [xx:xx:xx].....	101
→	System Date [xx/xx/xx].....	101
→	OnBoard PCI IDE Controller [Both]	104
→	DE Master and IDE Slave	105
→	Auto-Detected Drive Parameters	106
→	Type [Auto].....	107
→	ZIP	107
→	LS-120	107
→	LBA/Large Mode [Auto]	108
→	Block (Multi Sector Transfer) [Auto].....	108
→	PIO Mode [Auto].....	108
→	DMA Mode [Auto].....	109
→	S.M.A.R.T [Auto]	110
→	32Bit Data Transfer [Enabled]	110
→	Serial Port1 Address [3F8/IRQ4]	111
→	Serial Port1 Mode [Normal]	112
→	Serial Port2 Address [2F8/IRQ3]	112
→	Serial Port2 Mode [Normal]	112
→	Serial Port3 Address [3E8]	113
→	Serial Port3 IRQ [11].....	113
→	Serial Port4 Address [2E8]	113
→	Serial Port4 IRQ [10].....	114
→	ACPI Version Features [ACPI v1.0].....	116
→	Suspend Mode [S1(POS)]	116
→	TCG/TPM Support [Yes].....	118
→	TPM Enable/Disable Status [No State]	118
→	TPM Owner Status [No State].....	118
→	Remote Access [Disabled]	119
→	Serial Port Number	119

KINO-690S1 Mini-ITX Motherboard

➔	Serial Port Mode	119
➔	Flow Control.....	119
➔	Redirection after BIOS POST	119
➔	Terminal Type	119
➔	VT-UTF8 Combo Key Support.....	120
➔	Sredir Memory Display Delay	120
➔	Serial Port Number [COM1]	120
➔	Base Address, IRQ [3F8h,4]	120
➔	Serial Port Mode [115200 8,n,1].....	120
➔	Flow Control [None]	121
➔	Redirection After BIOS POST [Always].....	121
➔	Terminal Type [ANSI]	121
➔	VT-UTF8 Combo Key Support [Disabled]	122
➔	Sredir Memory Display Delay [Disabled]	122
➔	USB 1.1 EHCI Controller [Enabled].....	123
➔	USB 2.0 EHCI Controller [Enabled].....	123
➔	Legacy USB Support [Enabled]	124
➔	USB2.0 Controller Mode [HiSpeed].....	124
➔	USB Mass Storage Reset Delay [20 Sec]	125
➔	Device ##	126
➔	Emulation Type [Auto]	126
➔	Clear NVRAM [No]	129
➔	Plug & Play O/S [No]	129
➔	PCI Latency Timer [64].....	129
➔	Allocate IRQ to PCI VGA [Yes]	130
➔	Palette Snooping [Disabled].....	130
➔	PCI IDE BusMaster [Disabled].....	130
➔	OffBoard PCI/ISA IDE Card [Auto]	130
➔	IRQ# [Available]	131
➔	DMA Channel# [Available].....	132
➔	Reserved Memory Size [Disabled].....	133
➔	Quick Boot [Enabled].....	135

→	Quiet Boot [Disabled].....	135
→	PS/2 Mouse Support [Enabled]	136
→	Boot From LAN Support [Disabled].....	136
→	Change Supervisor Password.....	141
→	Change User Password	141
→	Boot Sector Virus Protection [Disabled].....	142
→	DRAM ECC Enable [Enabled].....	145
→	4-Bit ECC Mode.....	145
→	DRAM SCRUB REDIRECT [Disabled]	146
→	DRAM BG Scrub [Disabled].....	146
→	L2 Cache BG Scrub [Disabled].....	146
→	L1 Cache BG Scrub [Disabled].....	147
→	Internal Graphics Mode [UMA].....	148
→	UMA Buffer Size [Auto]	149
→	Current UMA Buffer Size [Auto].....	149
→	Primary Video Controller [IGFX]	149
→	TV Standard.....	149
→	Expansion Mode [Disabled].....	150
→	AC97 Audio Device.....	151
→	Set Spread Spectrum Function [Disabled]	151
→	OnChip SATA [Enabled]	152
→	OnChip SATA Type [Enabled]	152
→	Power Management/APM [Enabled]	153
→	Power Button Mode [On/Off]	153
→	Resume on Ring [Disabled].....	154
→	AT/ATX Power [ATX]	154
→	Restore on AC Power Loss [Last State].....	154
→	Resume On RTC Alarm [Disabled].....	155
→	RTC Alarm Date (Days)	155
→	System Time.....	155
→	Save Changes and Exit	156
→	Discard Changes and Exit	156

KINO-690S1 Mini-ITX Motherboard

→	Discard Changes	156
→	Load Optimal Defaults	157
→	Load Failsafe Defaults	157

THIS PAGE IS INTENTIONALLY LEFT BLANK

Appendix

B

DIO Interface

B.1 DIO Interface Introduction

The DIO connector on the KINO-690S1 is interfaced to GIO ports on the iTE Super I/O chipset. The DIO has both 4-bit digital inputs and 4-bit digital outputs. The digital inputs and digital outputs are generally control signals that control the on/off circuit of external devices or TTL devices. Data can be read or written to the selected address to enable the DIO functions.



NOTE:

For further information, please refer to the datasheet for the iTE Super I/O chipset.

B.2 DIO Connector Pinouts

The following table describes how the DIO connector pins are connected to the Super I/O GPIO port 1.

Pin	Description	Super I/O Pin	Super I/O Pin Description
1	Ground	N/A	N/A
2	VCC	N/A	N/A
3	XIN0	27 (GP20)	General purpose I/O port 2 bit 0.
4	XOUT0	23 (GP24)	General purpose I/O port 2 bit 4.
5	XIN1	26 (GP21)	General purpose I/O port 2 bit 1.
6	XOUT1	22 (GP25)	General purpose I/O port 2 bit 5.
7	XIN2	25 (GP22)	General purpose I/O port 2 bit 3.
8	XOUT2	21 (GP26)	General purpose I/O port 2 bit 2.
9	XIN3	24 (GP23)	General purpose I/O port 2 bit 6.
10	XOUT3	20 (GP27)	General purpose I/O port 2 bit 7.

B.3 Assembly Language Samples

B.3.1 Enable the DIO Input Function

The BIOS interrupt call INT 15H controls the digital I/O. An assembly program to enable digital I/O input functions is listed below.

MOV	AX, 6F08H	Sets the digital port as input
INT	15H	Initiates the INT 15H BIOS call

B.3.2 Enable the DIO Output Function

The BIOS interrupt call INT 15H controls the digital I/O. An assembly program to enable digital I/O output functions is listed below.

MOV	AX, 6F09H	Sets the digital port as output
MOV	BL, 09H	
INT	15H	Initiates the INT 15H BIOS call



THIS PAGE IS INTENTIONALLY LEFT BLANK

Appendix

C

Watchdog Timer

NOTE:

The following discussion applies to DOS environment. IEI support is contacted or the IEI website visited for specific drivers for more sophisticated operating systems, e.g., Windows and Linux.

The Watchdog Timer is provided to ensure that standalone systems can always recover from catastrophic conditions that cause the CPU to crash. This condition may have occurred by external EMI or a software bug. When the CPU stops working correctly, Watchdog Timer either performs a hardware reset (cold boot) or a Non-Maskable Interrupt (NMI) to bring the system back to a known state.

A BIOS function call (INT 15H) is used to control the Watchdog Timer:

INT 15H:

AH – 6FH Sub-function:	
AL – 2:	Sets the Watchdog Timer's period.
BL:	Time-out value (Its unit-second is dependent on the item "Watchdog Timer unit select" in CMOS setup).

Table C-1: AH-6FH Sub-function

Call sub-function 2 to set the time-out period of Watchdog Timer first. If the time-out value is not zero, the Watchdog Timer starts counting down. While the timer value reaches zero, the system resets. To ensure that this reset condition does not occur, calling sub-function 2 must periodically refresh the Watchdog Timer. However, the Watchdog timer is disabled if the time-out value is set to zero.

A tolerance of at least 10% must be maintained to avoid unknown routines within the operating system (DOS), such as disk I/O that can be very time-consuming.

**NOTE:**

When exiting a program it is necessary to disable the Watchdog Timer, otherwise the system resets.

Example program:

```
; INITIAL TIMER PERIOD COUNTER
```

```
;
```

```
W_LOOP:
```

```
    MOV    AX, 6F02H    ;setting the time-out value  
    MOV    BL, 30      ;time-out value is 48 seconds  
    INT    15H
```

```
;
```

```
; ADD THE APPLICATION PROGRAM HERE
```

```
;
```

```
    CMP    EXIT_AP, 1    ;is the application over?  
    JNE    W_LOOP      ;No, restart the application
```

```
    MOV    AX, 6F02H    ;disable Watchdog Timer  
    MOV    BL, 0        ;  
    INT    15H
```

```
;
```

```
; EXIT ;
```

THIS PAGE IS INTENTIONALLY LEFT BLANK

Appendix

D

Address Mapping

D.1 Address Map

I/O address Range	Description
000-01F	DMA Controller
020-021	Interrupt Controller
040-043	System time
060-06F	Keyboard Controller
070-07F	System CMOS/Real time Clock
080-09F	DMA Controller
0A0-0A1	Interrupt Controller
0C0-0DF	DMA Controller
0F0-0FF	Numeric data processor
1F0-1F7	Primary IDE Channel
2F8-2FF	Serial Port 2 (COM2)
378-37F	Parallel Printer Port 1 (LPT1)
3B0-3BB	AMD Graphics Controller
3C0-3DF	AMD Graphics Controller
3F6-3F6	Primary IDE Channel
3F7-3F7	Standard floppy disk controller
3F8-3FF	Serial Port 1 (COM1)

Table D-1: IO Address Map

D.2 1st MB Memory Address Map

Memory address	Description
00000-9FFFF	System memory
A0000-BFFFF	VGA buffer
F0000-FFFFF	System BIOS
1000000-	Extend BIOS

Table D-2: 1st MB Memory Address Map

D.3 IRQ Mapping Table

IRQ0	System Timer	IRQ8	RTC clock
IRQ1	Keyboard	IRQ9	ACPI
IRQ2	Available	IRQ10	LAN
IRQ3	COM2	IRQ11	LAN/USB2.0/SATA
IRQ4	COM1	IRQ12	PS/2 mouse
IRQ5	SMBus Controller	IRQ13	FPU
IRQ6	FDC	IRQ14	Primary IDE
IRQ7	Available	IRQ15	Secondary IDE

Table D-3: IRQ Mapping Table

D.4 DMA Channel Assignments

Channel	Function
0	Available
1	Available
2	Floppy disk (8-bit transfer)
3	Available
4	Cascade for DMA controller 1
5	Available
6	Available
7	Available

Table D-4: IRQ Mapping Table



THIS PAGE IS INTENTIONALLY LEFT BLANK

Appendix

E

Hazardous Materials Disclosure

E.1 Hazardous Material Disclosure Table for IPB Products Certified as RoHS Compliant Under 2002/95/EC Without Mercury

The details provided in this appendix are to ensure that the product is compliant with the Peoples Republic of China (China) RoHS standards. The table below acknowledges the presences of small quantities of certain materials in the product, and is applicable to China RoHS only.

A label will be placed on each product to indicate the estimated “Environmentally Friendly Use Period” (EFUP). This is an estimate of the number of years that these substances would “not leak out or undergo abrupt change.” This product may contain replaceable sub-assemblies/components which have a shorter EFUP such as batteries and lamps. These components will be separately marked.

Please refer to the table on the next page.

KINO-690S1 Mini-ITX Motherboard

Part Name	Toxic or Hazardous Substances and Elements					
	Lead (Pb)	Mercury (Hg)	Cadmium (Cd)	Hexavalent Chromium (CR(VI))	Polybrominated Biphenyls (PBB)	Polybrominated Diphenyl Ethers (PBDE)
Housing	X	O	O	O	O	X
Display	X	O	O	O	O	X
Printed Circuit Board	X	O	O	O	O	X
Metal Fasteners	X	O	O	O	O	O
Cable Assembly	X	O	O	O	O	X
Fan Assembly	X	O	O	O	O	X
Power Supply Assemblies	X	O	O	O	O	X
Battery	O	O	O	O	O	O

O: This toxic or hazardous substance is contained in all of the homogeneous materials for the part is below the limit requirement in SJ/T11363-2006

X: This toxic or hazardous substance is contained in at least one of the homogeneous materials for this part is above the limit requirement in SJ/T11363-2006

此附件旨在确保本产品符合中国 RoHS 标准。以下表格标示此产品中某有毒物质的含量符合中国 RoHS 标准规定的限量要求。

本产品上会附有“环境友好使用期限”的标签，此期限是估算这些物质“不会有泄漏或突变”的年限。本产品可能包含有较短的环境友好使用期限的可替换元件，像是电池或灯管，这些元件将会单独标示出来。

部件名称	有毒有害物质或元素					
	铅 (Pb)	汞 (Hg)	镉 (Cd)	六价铬 (CR(VI))	多溴联苯 (PBB)	多溴二苯醚 (PBDE)
壳体	X	○	○	○	○	X
显示	X	○	○	○	○	X
印刷电路板	X	○	○	○	○	X
金属螺帽	X	○	○	○	○	○
电缆组装	X	○	○	○	○	X
风扇组装	X	○	○	○	○	X
电力供应组装	X	○	○	○	○	X
电池	○	○	○	○	○	○

○: 表示该有毒有害物质在该部件所有物质材料中的含量均在 SJ/T11363-2006 标准规定的限量要求以下。
X: 表示该有毒有害物质至少在该部件的某一均质材料中的含量超出 SJ/T11363-2006 标准规定的限量要求。

Appendix

E

RAID Setup

F.1 Introduction

The AMD SB600 SATA RAID control can control serial ATA (SATA) disks and increase the data read/write speed and provide protection to data by distributing mirrored duplicates of data onto two disk drives (RAID 1).



CAUTION!

A configured RAID volume (which may consist of multiple hard drives) appears to an operating system as a contingent storage space. The operating system will not be able to distinguish the physical disk drives contained in a RAID configuration.

F.1.1 Precautions

One key benefit a RAID configuration brings is that a single hard drive can fail within a RAID array without damaging data. With RAID 1 array, a failed drive can be replaced and the RAID configuration restored.



WARNING!

Irrecoverable data loss occurs if a working drive is removed when trying to remove a failed drive. It is strongly recommended to mark the physical connections of all SATA disk drives. Drive locations can be identified by attaching stickers to the drive bays. If a drive member of a RAID array should fail, the failed drive can then be correctly identified.

KINO-690S1 Mini-ITX Motherboard



CAUTION!

Do not accidentally disconnect the SATA drive cables. Carefully route the cables within the chassis to avoid system down time.

F.2 Features and Benefits

- Supports RAID levels 0, 1, and JBOD
- Supports connectivity to two disk drives
- Windows-based software for RAID management

F.3 Accessing the AMD SB600 RAID Utility

To access the **AMD RAID Utility**, please follow the steps below:

Step 1: Connect SATA drives to the system. Connect at least two SATA drives to the system. Make sure the drives have the same capacity, are the same type and have the same speed.



NOTE:

Make sure the SATA drives are EXACTLY the same when they are configured in a RAID configuration (JBOD, RAID 0 or RAID 1). If they are not the same size, disk drive capacity is sacrificed and overall performance affected.

Step 2: Enable SATA drives in BIOS. Start the computer and access the **AMI BIOS** setup program. Next, open the **Southbridge Setup** menu. Enable the **OnChip SATA Channel** option and change the **OnChip SATA Type** to **RAID**.

Step 3: Save and Exit BIOS. After the **SATA ROM Support BIOS** option is enabled, save and exit the **BIOS**.

Step 4: Reboot the system. Reboot the system after saving and exiting the **BIOS**.

Step 5: Press Ctrl-F. The following screen appears.

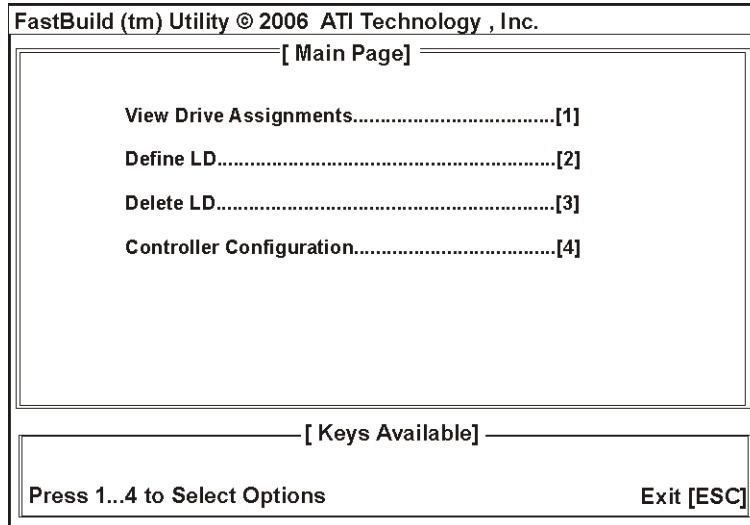

Figure F-1: Accessing AMD RAID BIOS Utility

Step 6: Delete RAID settings and partitions. Select **Delete LD** by pressing **3** in the **Main Page** menu above. Next, delete the drives individually.

Step 7: Define the Logical Drive (LD). Select **Define LD** by pressing **2** in the **Main Page** menu above.

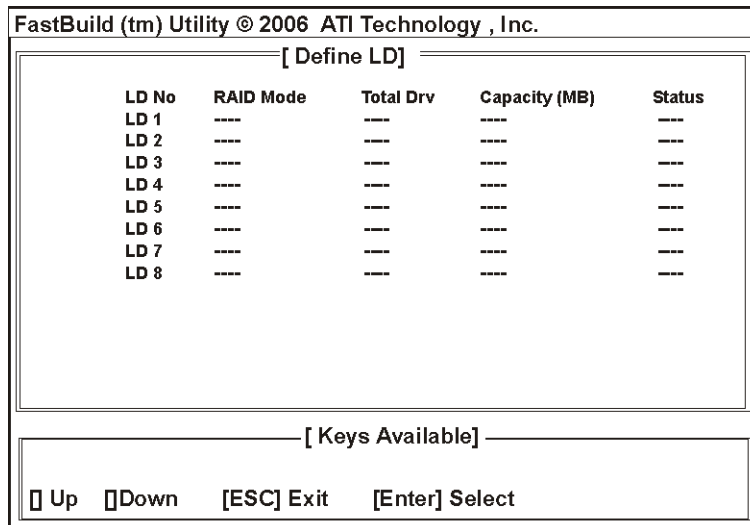

Figure F-2: Define LD

Step 8: The RAID Configuration Options screen shown below appears.

KINO-690S1 Mini-ITX Motherboard

FastBuild (tm) Utility © 2006 ATI Technology , Inc.

[Define LD]

LD No	RAID Mode	Total Drv
LD 1	RAID 1	0

Stripe Block: 64KB
Gigabyte Boundary: ON

Fast Init.: OFF
Cache Mode: WriteThru

[Drives Assignment]

Channel ID	Drive Model	Capacity (MB)	Assignment
1: Mass	xxxxxxxxxx	yyy	N
2: Mass	xxxxxxxxxx	yyy	N
3: Mass	xxxxxxxxxx	yyy	N
4: Mass	xxxxxxxxxx	yyy	N

[Keys Available]

Up Down [ESC] Exit [Space] Change Option [Ctrl-Y] Save

Figure F-3: RAID Configuration Options

Step 9: Configure the RAID. Use the configuration options in the **RAID Configuration Options** menu shown above to configure the RAID.

Step 10: Select the RAID Mode. The following RAID configuration options are available.

- JBOD
- RAID 0
- RAID 1
- RAID 10

Step 11: Select the stripe block. If necessary, select the stripe block.

Step 12: Select the drives. For a logical drive, at least two drives must be selected.

Step 13: Select the Capacity. For each drive, select the capacity of the drive that should be allocated to the logical drive.

Step 14: Assign the drive. For each drive, select “Y” in the assignment option.

Step 15: Save. Press “Ctrl-Y” to save the RAID configuration settings.

Step 16: The **LD Define** screen reappears with the newly configured LD showing.

FastBuild (tm) Utility © 2006 ATI Technology , Inc.

[Define LD]

LD No	RAID Mode	Total Drv	Capacity (MB)	StatusLD
LD1	RAID 1	2	100	Functional
LD 2	----	----	----	----
LD 3	----	----	----	----
LD 4	----	----	----	----
LD 5	----	----	----	----
LD 6	----	----	----	----
LD 7	----	----	----	----
LD 8	----	----	----	----

[Keys Available]

Up Down [ESC] Exit [Enter] Select

Figure F-4: RAID Configuration Options

Step 17: Exit the Define LD screen. To exit, press “Escape.” The **Main Menu** reappears.

Step 18: Exit the Main Menu and reboot. When exiting the main menu, a prompt appears asking if the user wishes to reboot the system. Press “Y” to continue.

Step 19: The system starts to reboot.

Step 20: Install the OS. After the RAID array has been configured install the OS. To do this, please refer to the documentation that came with the OS.

Index

A

ACPI	101, 115, 116
Advanced Power Management	153
airflow	82
anti-static precautions	32, 70
anti-static pad	32, 70
anti-static wristband	32, 70
handling.....	32, 70
self-grounding	32, 70
ASKIR interface.....	46
ATA flat cable.....	84
ATX.....	40
ATX power connector	4, 40
audio connector	60
audio connector, external	61
Audio device connector	90
audio devices, external.....	61
audio jack	60
audio jack	61

B

BIOS25, 98, 99, 100, 101, 102, 103, 104, 105, 106, 111, 114, 115, 116, 117, 118, 119, 121, 122, 123, 124, 125, 127, 128, 133, 134, 135, 136, 137, 138, 140, 141, 142, 143, 144, 150, 151, 152, 153, 155, 156	
BIOS chipset.....	25

C

cables.....	83
-------------	----

ATA 66/100 flat cable	33
dual port USB	87
dual RS-232	34, 85
four port USB.....	88
SATA drive.....	34, 86
SATA drive power.....	34, 86
chassis	82
installation.....	82
chipset driver.....	162
clear CMOS jumper	4, 80
location.....	80
settings	80
CMOS	80
clear CMOS jumper	80
COM 2	56
COM 2 function select.....	81
connector location and pinouts	56
RS-232, RS-422 or RS-485	56
COM 2 function select jumper.....	56, 81
location.....	81
settings	81
connectors, external	
audio jacks	60
COM 1 serial port	66
DVI connector.....	61
keyboard PS/2 connector	63
mouse PS/2 connector.....	63
USB port	66
connectors, pinouts and location	
ATX power	40
COM 2 serial port	55, 56
fan	42
front panel.....	43
IDE.....	45

KINO-690S1 Mini-ITX Motherboard

infrared interface.....	46
PCI Express x1 slot.....	52
PCI slot.....	47
serial port (COM 2).....	55, 56
trusted platform module (TPM).....	57
TV out.....	58
USB (internal).....	59
cooling.....	82
airflow.....	82
cooling fan.....	42, 76, 77, 115
cooling kit installation.....	76
CPU	
cooling fan.....	76
heat sink.....	76
installation.....	74

D

DB-15 connector.....	95
DB-9 connector.....	93
digital input/output connector.....	42
location and pinouts.....	42
dimensions.....	8
board.....	8
external peripheral interface connector panel.....	9
Drivers	
Broadcom GbE LAN.....	167
Realtek AC`97 Audio - ALC655... ..	172
dual port USB cable.....	87
DVI.....	90
DVI connector.....	61
DVI connector.....	4, 61
DVI Display Device.....	90
connection.....	90

DVI connector.....	90
--------------------	----

E

electrostatic discharge.....	32, 70
Enhanced Hardware Monitor.....	27
Ethernet.....	89
RJ-45 cable connector.....	89
RJ-45 connector.....	4
Ethernet controllers.....	65
external indicators.....	43
external peripheral interface.....	89
connection.....	89
connectors.....	89
external switches.....	43

F

fan connector.....	4, 42
location and pinouts.....	42
fan speed controller.....	27
FDD.....	111
four port USB cable.....	88
front panel connector.....	4, 43
location and pinouts.....	43

H

hard disk drives	
SATA.....	54
heat sink.....	76

I

IDE connector, 40-pin.....	4, 45
location and pinouts.....	45
IDE device.....	84

KINO-690S1 Mini-ITX Motherboard

ATA flat cable.....	84
connector.....	84
infrared interface.....	46
Amplitude Shift Key Infrared.....	46
ASKIR.....	46
Serial Infrared.....	46
SIR.....	46
infrared interface connector.....	4, 46
location and pinouts.....	46
installation checklist.....	72
IrDA	112, 113

J

jumper.....	79
clear CMOS.....	80
COM 2 function select.....	81
jumper configuration.....	79
jumper settings.....	79

K

keyboard connector.....	63
keyboard connector.....	63
keyboard controller.....	27

L

LAN connection.....	91
LPC bus.....	25
LPC interface.....	19, 27

M

memory module installation.....	78
motherboard.....	83
installation.....	83

mouse connector.....	63
----------------------	----

P

PCI Express x1 Slot.....	52
location and pinouts.....	52
PCI interface.....	17
PCI slot.....	4
PCI slot.....	4, 47
location and pinouts.....	47
peripheral connectors.....	40
peripheral device cables.....	83
power button.....	43
Power Button Mode.....	153
PS/2 connector.....	63
PS/2 connector.....	4, 63
PS/2 keyboard and mouse connection.....	92

R

RAID.....	54
RAID Accessing the ALi RAID Utility... Features and Benefits..... Precautions.....	201 201 200
real time clock.....	24
RJ-45 connection.....	91
single connector.....	91
RJ-45 Ethernet connector.....	4, 65
RJ-45 LAN connectors.....	65
RS-232.....	55, 56, 57, 66, 85
cable connection.....	85
COM 1 location and pinouts.....	66
COM 2 location and pinouts.....	55, 56
COM 3 location and pinouts.....	56

KINO-690S1 Mini-ITX Motherboard

COM 4 location and pinouts	56
connector location and pinouts	55, 56, 66
dual cable	85
serial port devices	55
RS-232 serial port connector	4
RS-232 serial port devices	55
RS-422	56
COM 2 location and pinouts	56
RS-485	56, 57
COM 2 location and pinouts	56

S

SATA	
controller	20
SATA drive	86
cables	86
connection	86
power cable	86
SATA drive connector	4, 54
location and pinouts	54
SATA drives	54
Serial Device	
connection	93
serial port	66
serial port connector	55, 56, 66
location and pinouts	55, 56, 66
serial ports	27
SIR interface	46
socket 479 CPU	
cooling kit	76
cooling kit installation	76
installation	74
SODIMM	78

installation	78
specifications	78
Super I/O chipset	25, 26
system voltages	114, 115

T

technical specifications	5
temperature	114
TPM connector	4
trusted platform module	57
trusted platform module (TPM)	
connector	57
location and pinouts	57
TV out connector	58
location and pinouts	58
TV Out connector	4

U

unpacking	32, 73
unpacking checklist	33
unpacking precautions	32, 73
USB	59, 60, 87, 88, 122, 123, 124
cable	
dual port	87
four port	88
cable	87, 88
cable connection	87
connectors	87
controller	18
devices	59
external USB device connection	94
port	59
USB 1.1	59
USB 2.0	59

KINO-690S1 Mini-ITX Motherboard

USB 1.1	59
USB 2.0	59, 123
USB 2.0 port	67
USB cable	
dual port	87
four port	88
USB connector, internal	4, 59
location and pinouts	59
USB device connection	94
dual connector	94

USB port	66
----------------	----

V

VGA	95
VGA monitor	95
connection	95

W

warranty validation	72
---------------------------	----